

# AMSTRAD



## PCW9512 PERSONAL COMPUTER WORD PROCESSOR SERVICE MANUAL

## IMPORTANT NOTES TO SERVICE ENGINEERS

This Service Manual gives indepth technical information on all of the circuits and the P.C.B.'s which make up the PCW9512. Much of this data is for information purposes only as the procedure engineers will follow when servicing this equipment will often be to exchange Printed Circuit Boards. In some instances Amstrad will insist that subassemblies are returned for exchange and should not be serviced by Service Engineers.

Please take note of the following information before attempting to service the equipment.

1. Full diagnostics are not specified in this manual. A diagnostic tool, designated the R.P.6., is available from Amstrad or approved spares agent and gives certain diagnostic information on the Computer. To carry out any indepth fault-finding this diagnostic tool is necessary.
2. The Disc Drive Mechanism and accompanying Printed Circuit Boards should not be serviced by Service Engineers. Exchange mechanisms complete with P.C.B.'s are available from Amstrad or approved spares agent.
3. Information is given on the parts for the Printer Mechanism but complete Printer Assemblies are available on an exchange basis and under normal circumstances, unless the problems are fairly straight forward, you should arrange for an exchange Printer Mechanism.
4. Complete Printed Circuit Boards are available on an exchange basis and unless the Service Engineer is particularly familiar with this product arrangements should be made to exchange the P.C.B.'s where a fault has developed. The R.P.6. diagnostic referred to above can be used to ensure correct diagnosis of the P.C.B. fault.
5. In some instances a second Disc Drive will be fitted to the PCW9512. This second Disc Drive is subject to seperate service information but under no circumstances should any service work be carried out on the mechanism or its Printed Circuit Board. In the event of a fault on the second Disc Drive arrangements should be made to exchange this.
6. Service Engineers carrying out any repairs on this unit can contact the Technical Advice Section of Amstrad for further information should they have any difficulty.

The PCW9512 is a sophisticated piece of computer technology and service work should only be undertaken on this equipment by suitably qualified personnel and preferably by appointed Amstrad Service Agents.

## Software Errors

If a drive fault is reported the fault may be a software problem. Before investigating the drive please carry out the following checks to ensure it is not a software problem.

### Detection and Correction of "Soft Errors"

Soft errors are usually caused by the following reasons.

- 1) Random external noise of several usec or less.
- 2) Minute off-tracking and shifting of write timing that are not detected during the write operation which may cause the soft error during the read.

To remedy such soft errors, take the following procedures at the controller side.

- 1) Repetitive reading on the track by 10 times or more until the data is restored.
- 2) When the data is not restored by step 1, access the head to the adjacent track in the same direction as move previously, and thereafter return the head to the original track.
- 3) Repeat the step 1.
- 4) If the data is not restored by the above steps, the error cannot be remedied.

### Write Error

When an error is caused during the write operation, the error is usually detected during the next rotation through the read operation called "Write Check".

To correct the error, repeat the write operation again and carry out the Write Check.

If the result is still incorrect even after the write operation is repeated more than 10 times, either the disc or the drive are working incorrectly. To find out the trouble source, carry out the read operations with another track. Should the error still be found, change the disc and repeat the above procedures. Should error still be found, the disc drive should be considered defective. If the error is removed, the original disc must be defective. Discard it.

### Seek Error

- 1) Step motor or step motor drive circuit is defective.
- 2) The torque of the carriage is not correct.

Restoration procedures from the seek error.

Make the re-calibration to the track OO. Then, carry out the re-seek to the original track.

### Notes:

- 1) Always ensure the head is clean.
- 2) Index/Sector Factor (Ready Defect)

As the unit has Optional Read Output

It is normally not ready until 2 revolutions are made after the disc insertion.

### Read Error

Most of the errors are "Soft Errors", in such a case the data are restored by following "Detection and Correction of Soft Errors" correction procedure.

# Diagnostic Flow Chart For FD4

This chart must be used in conjunction with the Alignment Procedures

This chart is for information only and does not guarantee an exact diagnosis. For warranty purposes any faulty drive mechanism must be returned to Amstrad for replacement. Service Agents should not attempt any repairs on the mechanism or to its P.C.B.

3-A

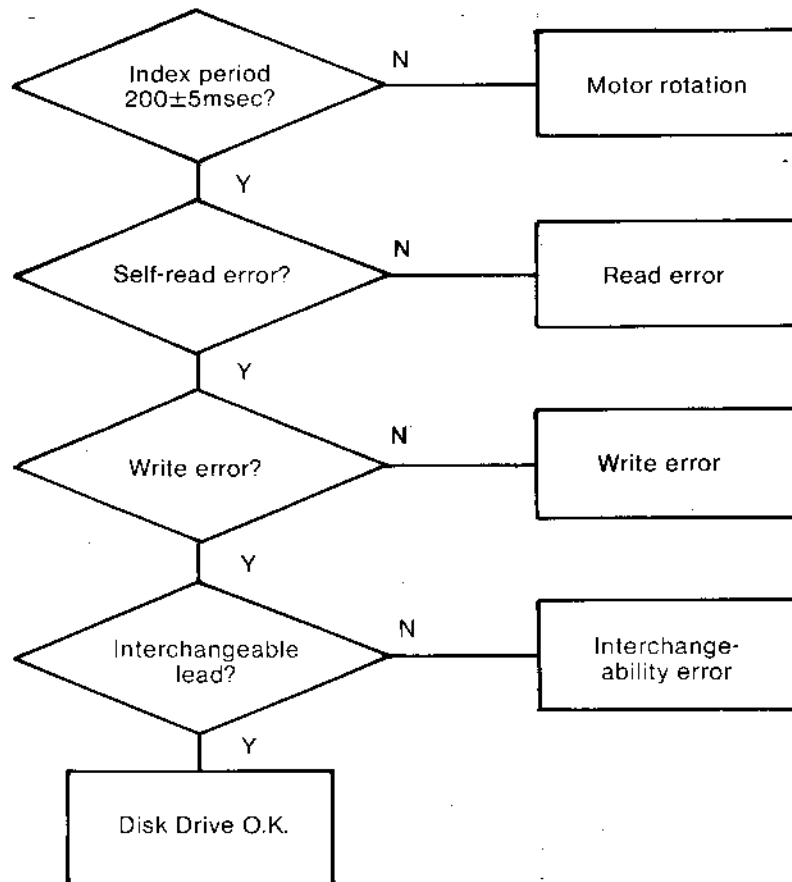

# FLOW CHART (cont)

3-B

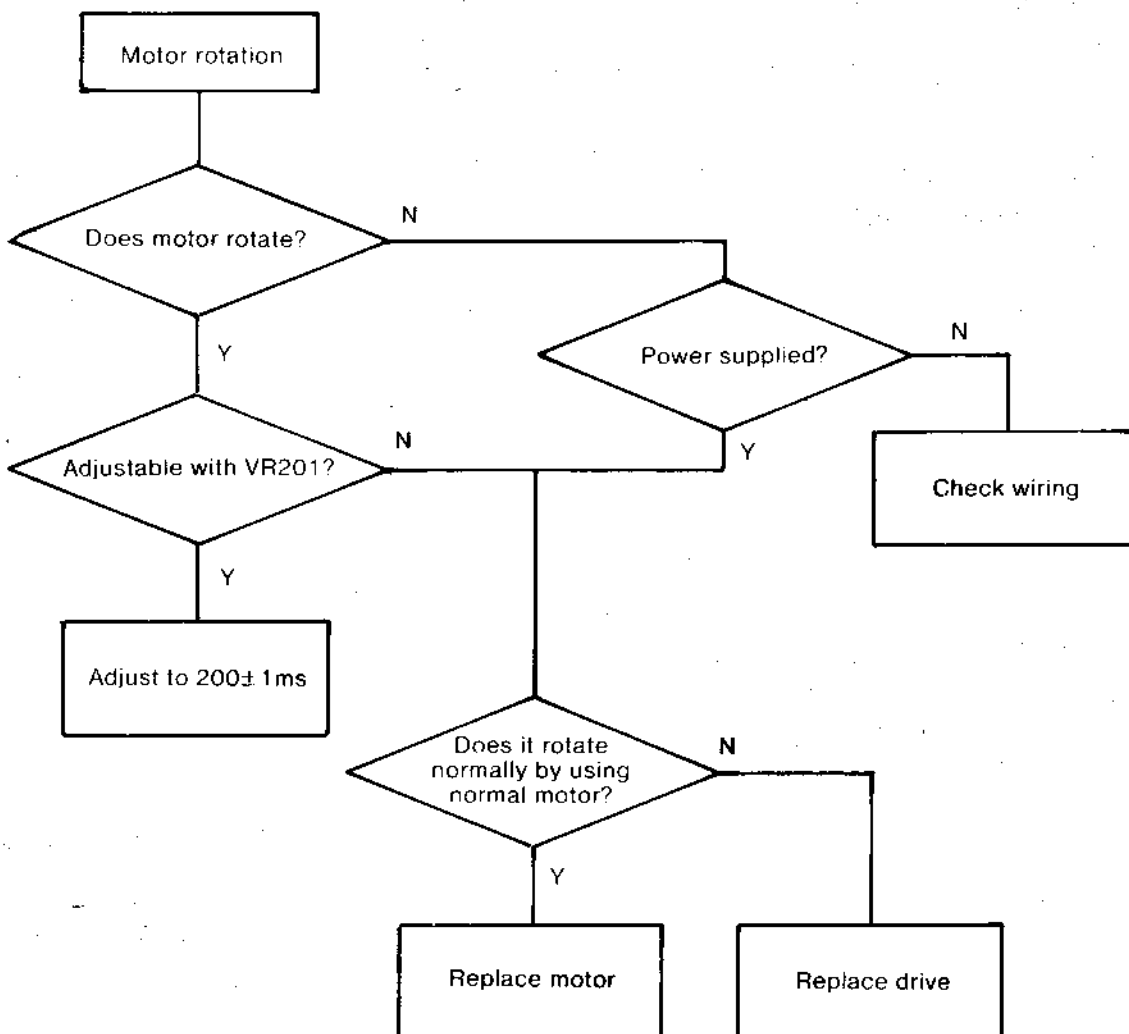

3-C

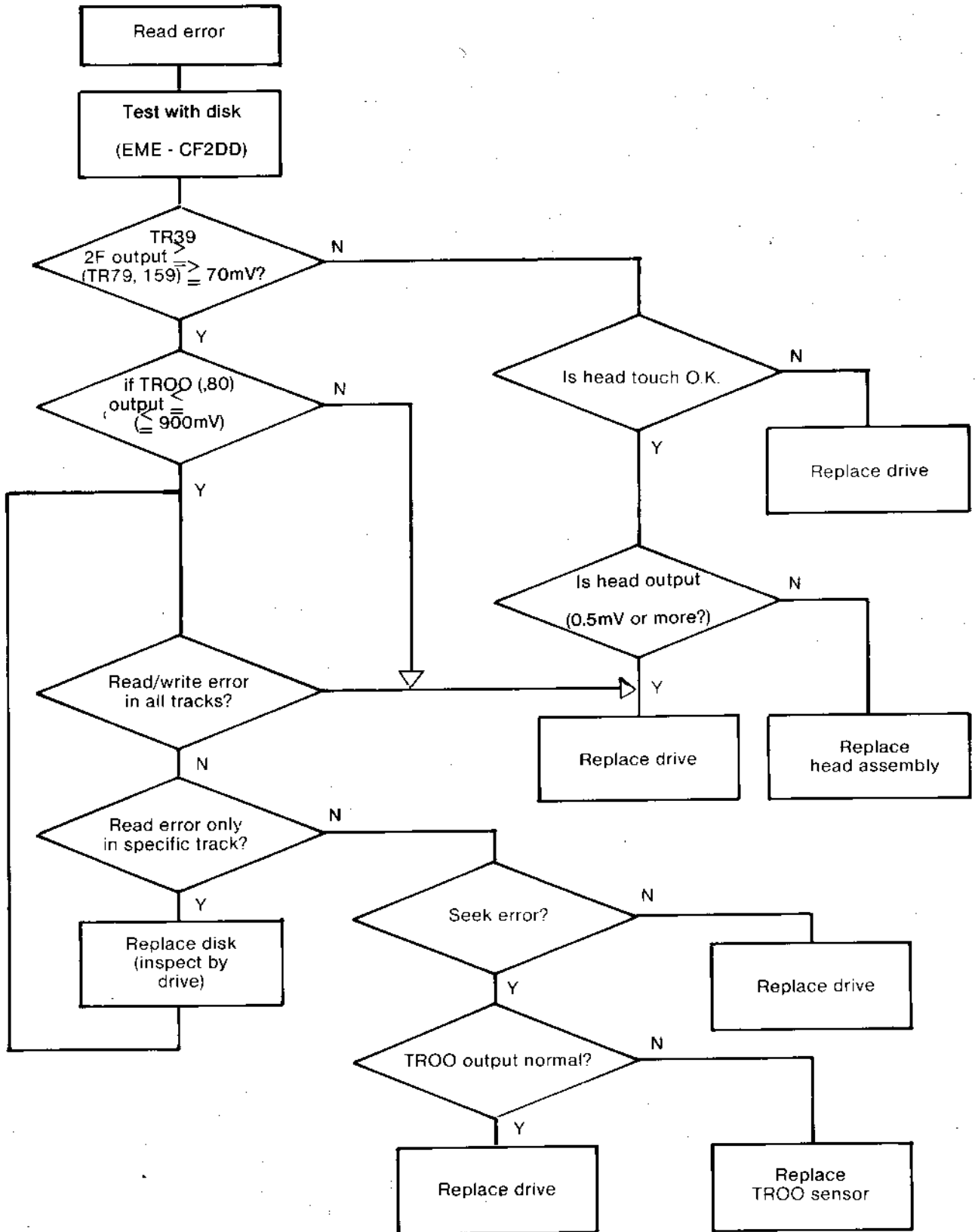

# FLOW CHART (CONT)

3-D

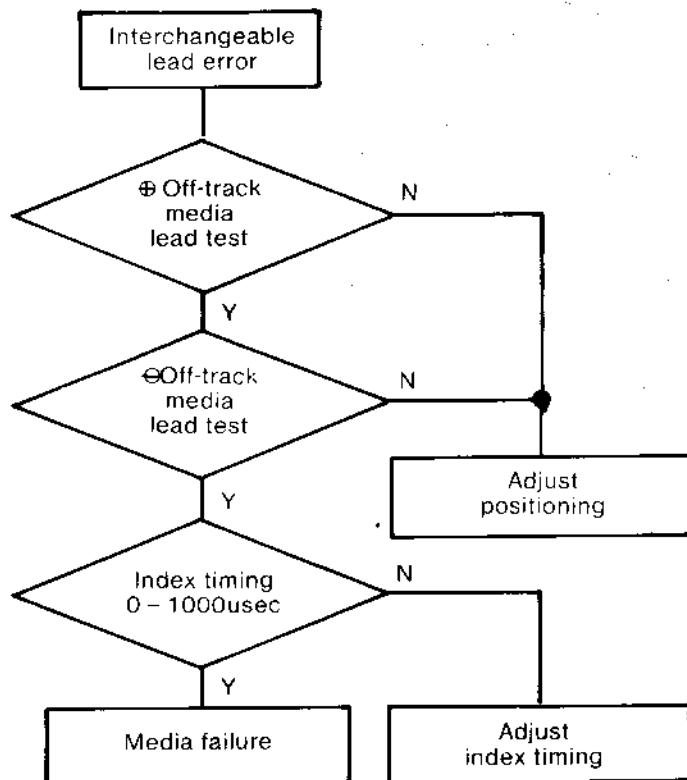
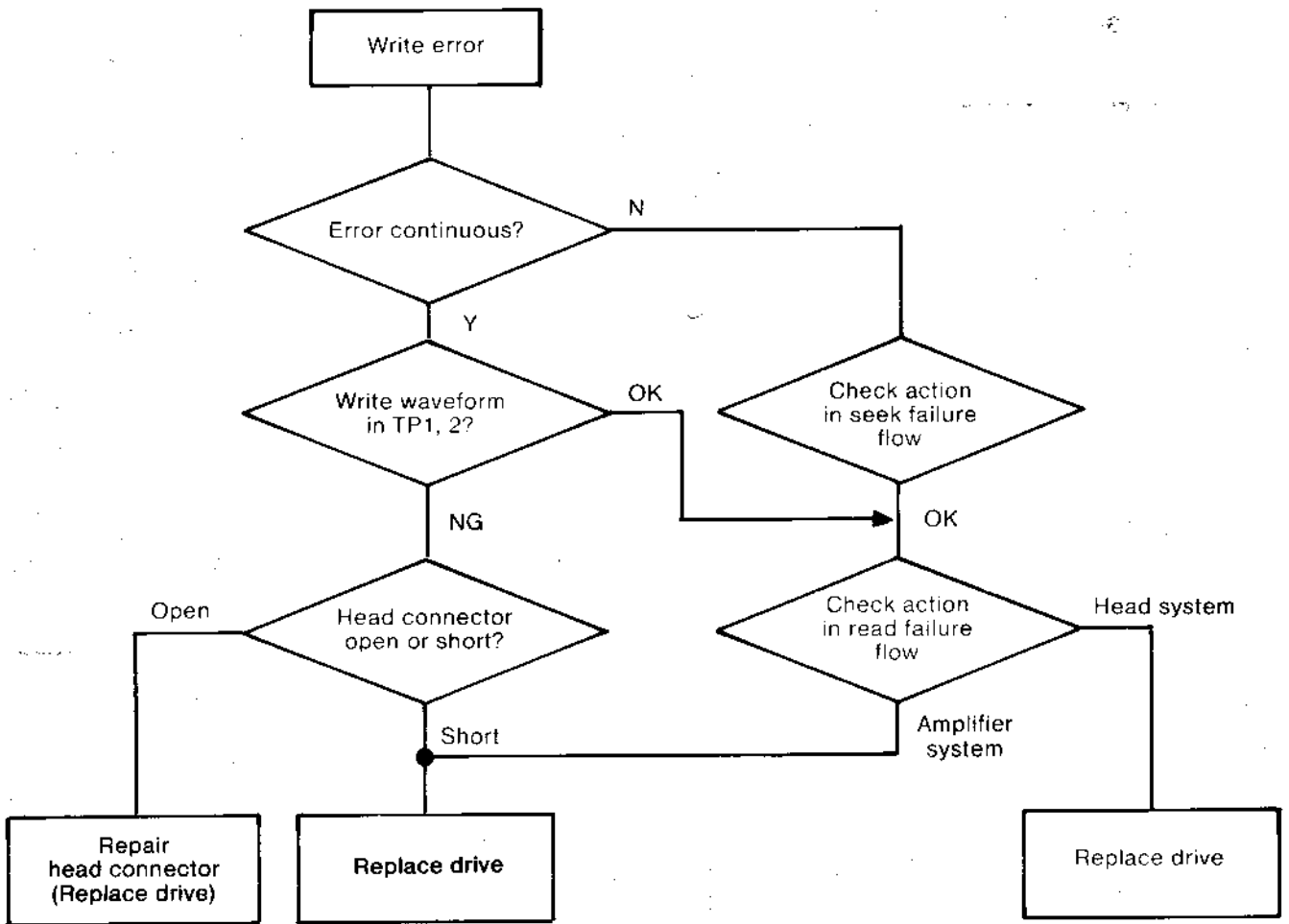

## FLOW CHART (CONT) FOR FD2 ONLY

3-E

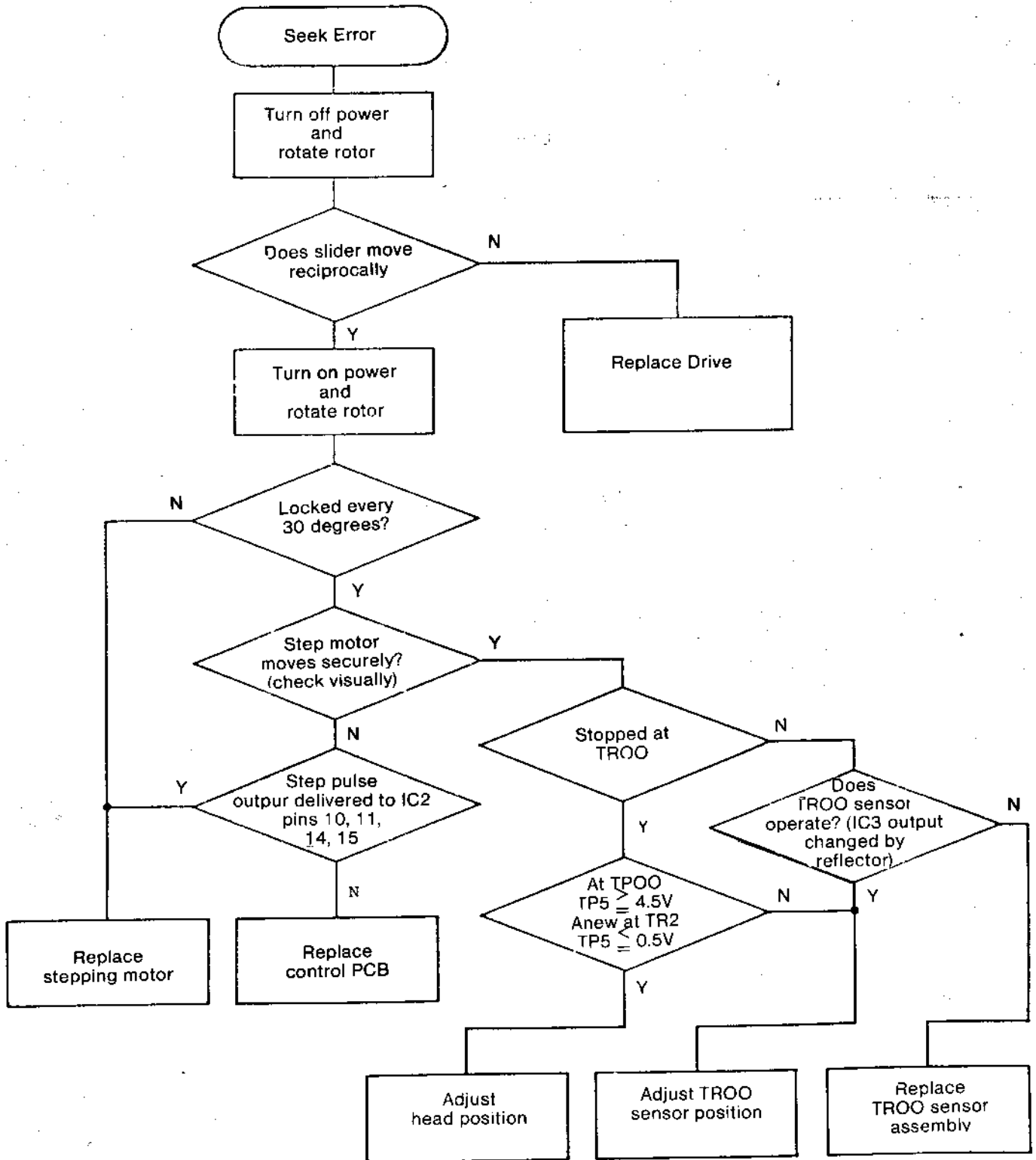



## MECHANICAL REPLACEMENTS

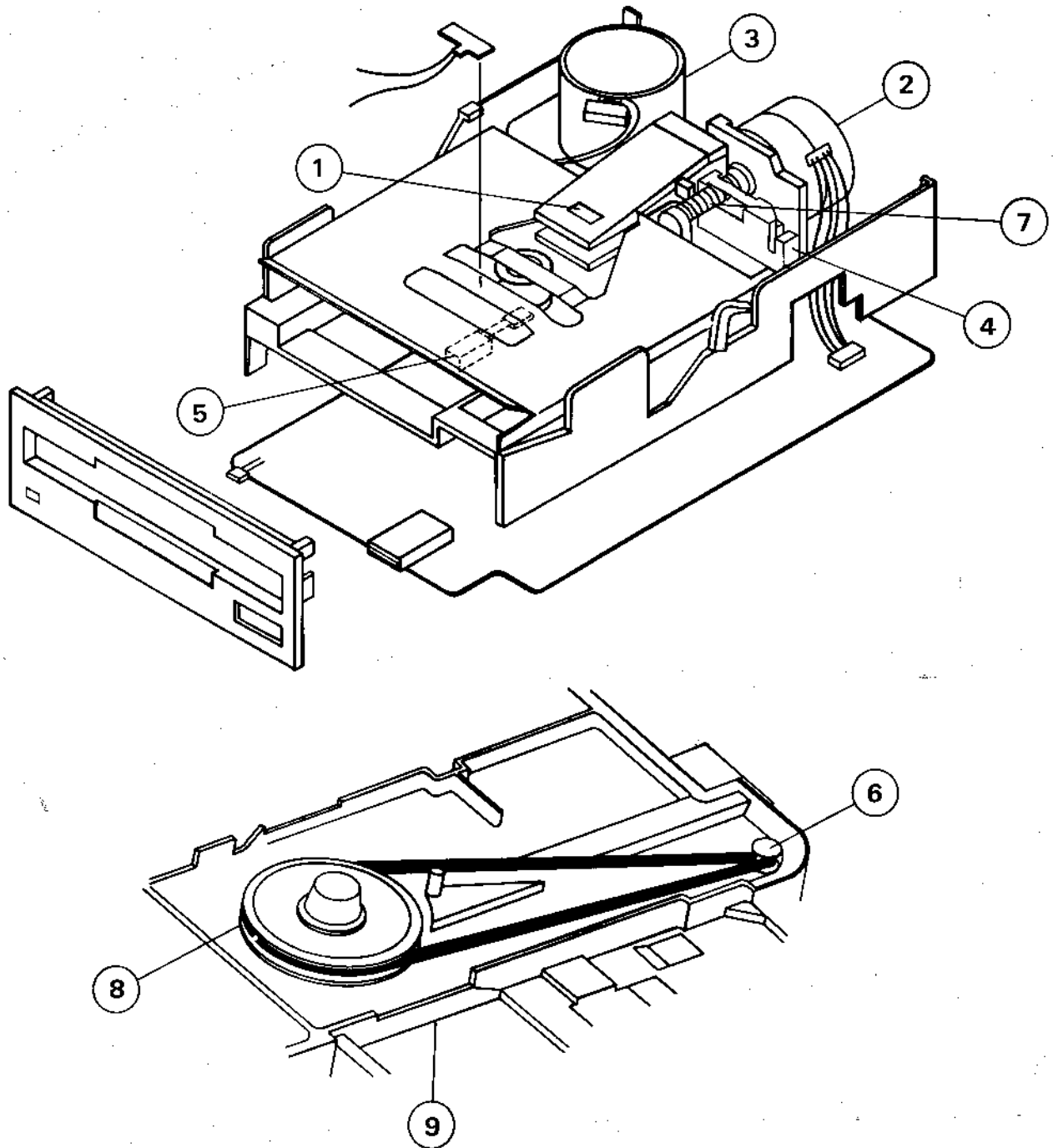

Sym	Description
1.	Head Bracket Assembly
2.	Stepper Motor
3.	Spindle Motor
4.	Track OO Sensor
5.	Read/Write Protect Index/LED P.C.B.
6.	Pulley
7.	Stepper Motor Shaft
8.	Flywheel
9.	Loading Unit

The data contained in the following 4 pages is for information only. Service Agents must not carry out any repair or adjustment to the Drive mechanism and its associated PCB during warranty. Faulty mechanism must be returned to AMSTRAD for exchange.

## Alignment Checks

Information within brackets is only for FD2

Please use this information in conjunction with the diagnostic flow chart.

Equipment required: Double Beam Scope; (EME - CF2DD) Test Disk (please refer to disk notes for usage).

The following checks can be carried out in routine servicing. If the wave patterns do not appear this confirms a fault with the mechanism. Before attempting any replacement check these waveforms thoroughly.

Content of adjustment and checking	CE DISK EME CF2 DD
1. Radial adjustment by use of Track 39, 119. Fig.1.	○
2. Adjustment of the index burst by use of Track 79, 159. Fig. 2.	○
3. Azimuth check by use of Track 79, 159. Fig. 3-4.	○

List of Test Points

Test point	Name of signal
TP 1	Read signal of filter outlet
TP 2	Read signal of filter outlet
TP 3	Signal ground
TP 5	TROO sensor output
TP 9	Index signal
TP 11	Signal ground

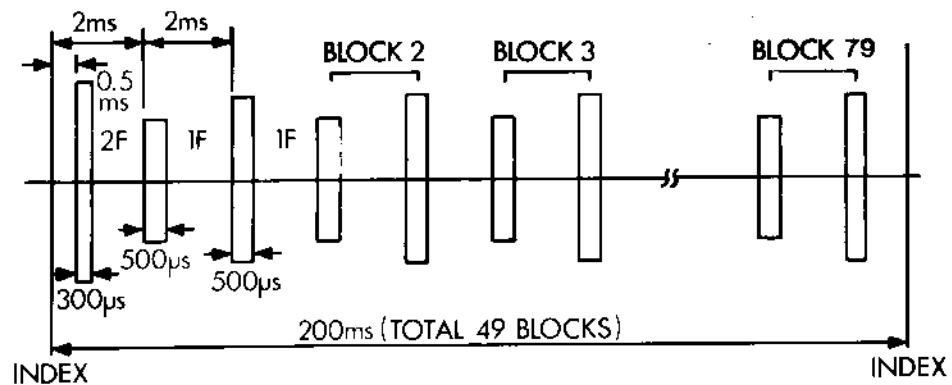

Fig. 1 Waveform of T39, 119 (Servo pattern)

# ALIGNMENT CHECKS

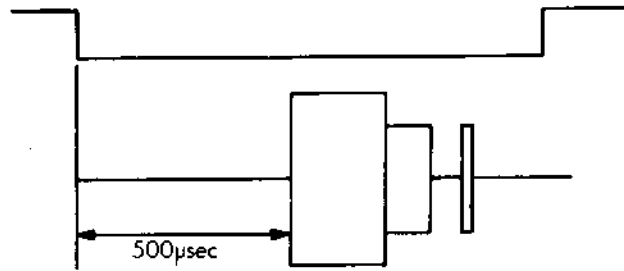

Fig. 5-1 Index burst waveform

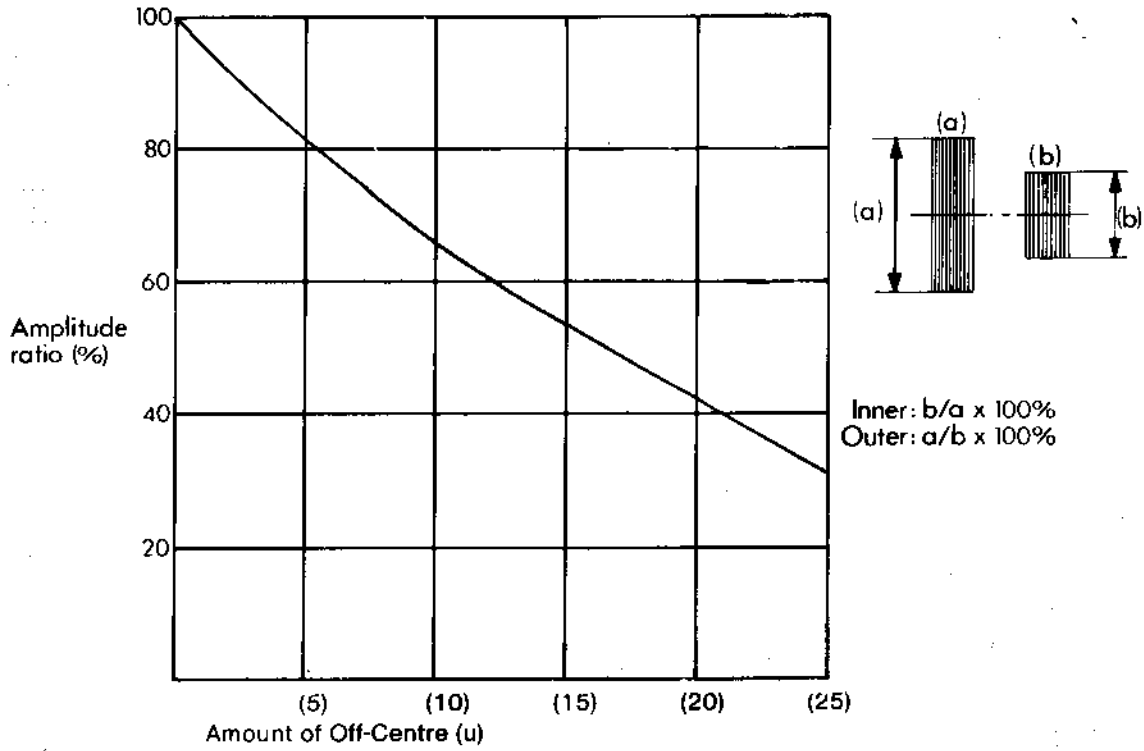

Fig. 5-2 Off-centre calibration curve  
[Effective width of read head is (90u).]

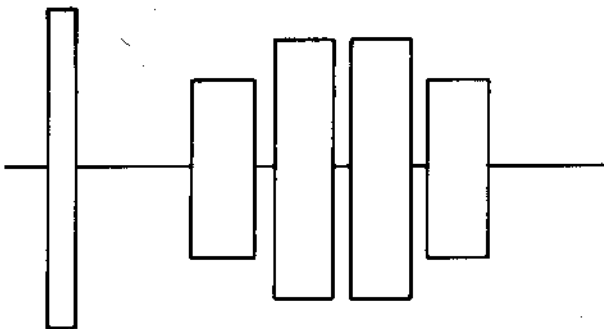

Fig. 5-3 Azimuth burst

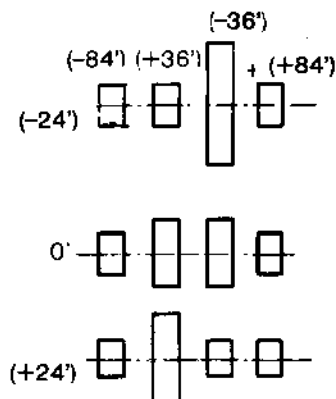

Fig. 5-4 shows azimuth burst in the cases of azimuth (-24, 0 and +24).

**ALIGNMENT CHECKS (cont)**

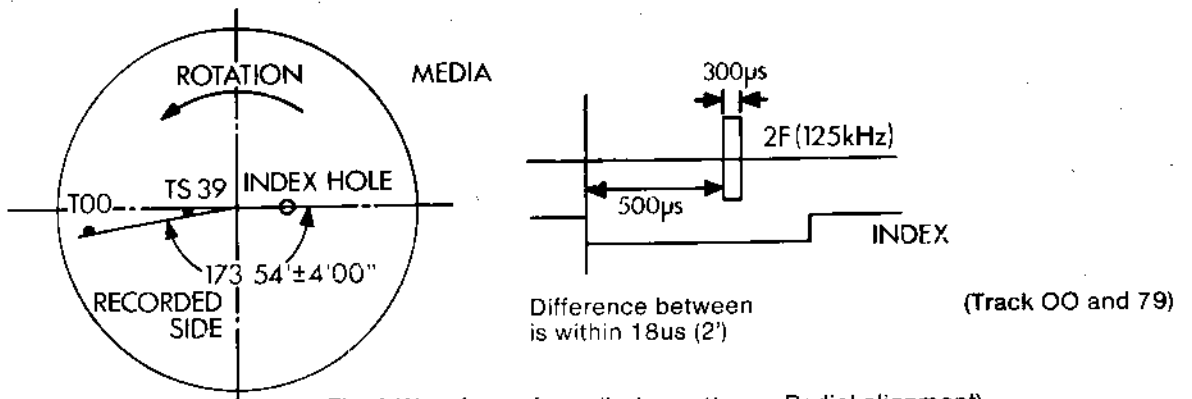

Fig. 2 Waveform of (Index pattern - Radial alignment)  
(Waveform of T79, 159)

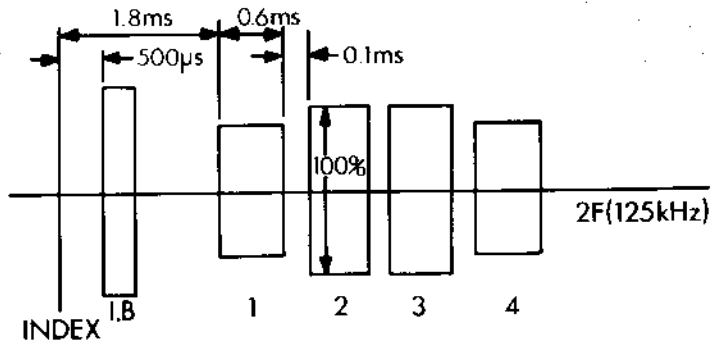

Fig. 3 Waveform of (Azimuth, alignment)  
(Waveform of T79, 159)

## ALIGNMENT CHECKS (cont)

### 1) Check Positioning

- 1) Load CE Disk.
- 2) Set up track 00, Motor off.
- 3) Scope to TP5.
- 4) Adjust OO Sensor (8 on Fig. 6) so that scope shows correct difference as Fig. 2.

### 2) Adjustment of Index Timing

- 1) Load the CE Disk (refer to disk info)
- 2) Step the disk to the track (Track 79).
- 3) Synchronise the oscilloscope by TP9 (INDEX). Set the time base to 0.1msec/DIV.
- 4) Connect the probe to TP1.  
Connect the ground probe to TP3 and TP11 (ground) of PCB.  
Set the input to AC and set the vertical axis to 20mV/DIV.
- 5) Measure timing between sweep start and an initial data pulse. It should be 500 usec  $\pm$ 500 usec. When the timing is not within this range, proceed with the following adjustment. (Refer to Fig. 5-1).
- 6) Loosen the two screws fixed LED printed board. Adjust the position of LED printed board so that the timing is 500 usec ( $\pm$ 200 usec).
- 7) Re-check the timing.
- 8) Seek to the track 00 and make sure that the timing is within 500 usec ( $\pm$ 300 usec).  
Tighten the screws. (Fig. 5-1).

### 3) Check of Head Output

This check is effective only when making write and read check as described below. If the output level is less than the prescribed output, clean the head before check.

Disk used for this check must be in good condition.

- 1) Load the CE Disk. (EME CF2DD).
- 2) Select track (Track 79).
- 3) Connect one of the probes of the oscilloscope to TP1 of the printed circuit board, another probe to TP2, and the probe to ground to TP3, TP11 (ground).  
Invert one channel, and set it to Add input, set input to AC, and set the vertical axis to 50mV/DIV and the horizontal axis to 20msec/DIV.
- 4) Make sure the average output level is the following value or more: (70 mV p-p) [SN 25dB or more]. If the output is less than the above-described value, replace the head.

### 4) Adjustment of Positioning

- 1) Load the CE disk (EME CF2DD).
- 2) Select track (Track 39).
- 3) Monitor the output in the same way as the head output inspection.  
Calculate the off-track amount in reference to the calibration graph, showing the interrelation between the burst amplitude ratio and off-track amount. (Refer to Fig. 5-2).
- 4) The average of amplitude ratio should be below (19  $\mu$ m).  
If it is not within this range, make the following adjustment.
  - i) Loosen the bolt of the rotation stopper which fixes the screw shaft (Fig. 6-3).  
Rotate the screw shaft and adjust it in such a way that the amplitude ratio may become below (5  $\mu$ m). Tentatively set the bolt at that position.
  - ii) Make the track step to the inner and outer circles and bring it to the original position. Make sure that the adjustment is all right. Then, tighten the bolt.

### 5) Confirmation of Head Azimuth

- 1) Load the CE Disk (EME CF2DD).
- 2) Select track (Track 79).
- 3) Synchronise the probe of the oscilloscope by TP9 of PCB and connect another probe to TP1, and the probe ground to TP3, TP11 (ground). Set the input to AC, the vertical axis to 10mV/DIV, and the horizontal axis to 0.5msec/DIV. Make sure that the two outside burst waveforms are smaller than two inside burst waveforms as shown in Fig. 5-3.  
Note: Signal preceding the azimuth burst is the index burst.  
If the azimuth is still incorrect replace the head assembly.

# FD4 SCHEMATIC DIAGRAM

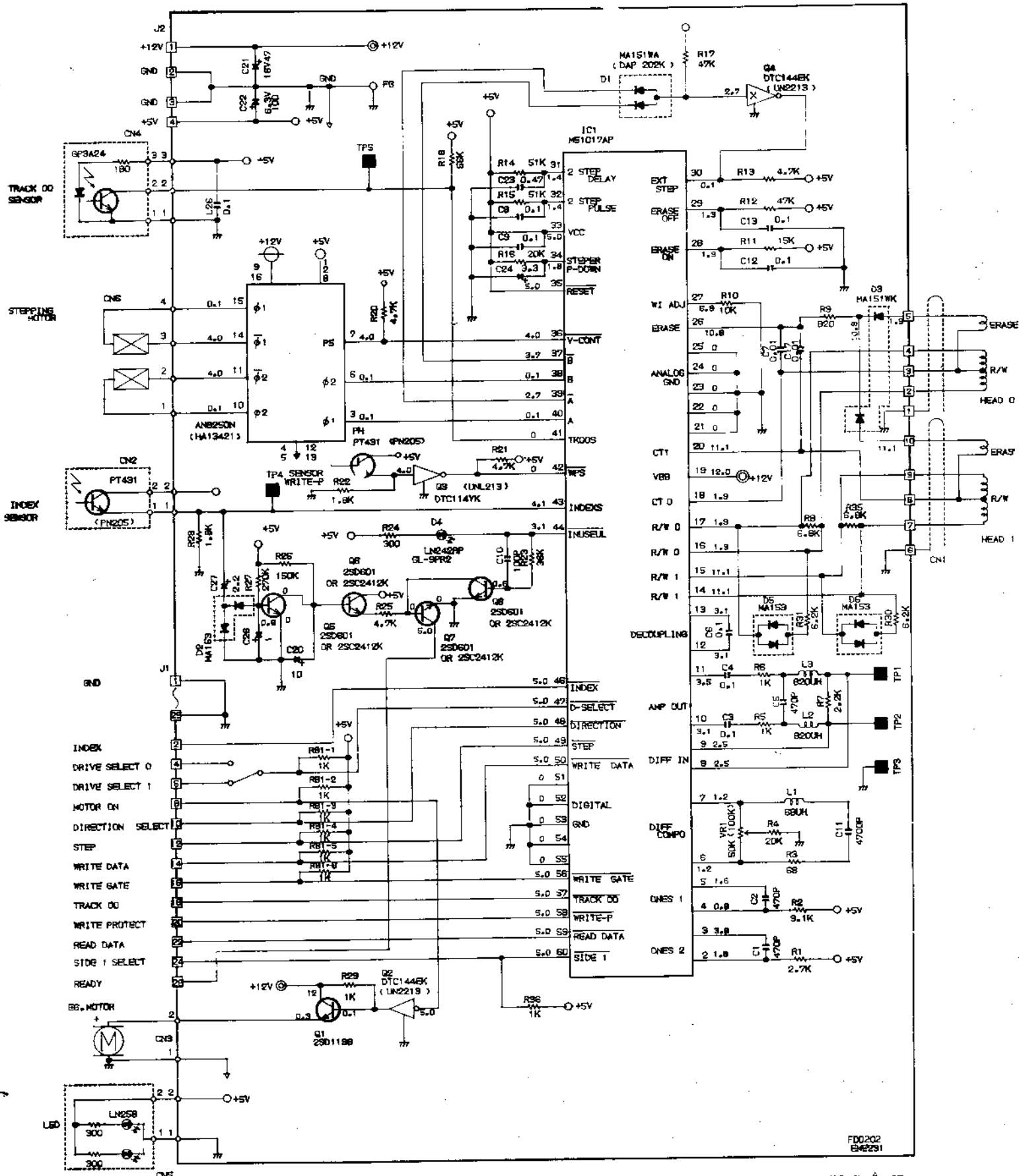

FD0202  
EM2291

CAUTION: SINCE THESE PARTS MARKED BY ARE CRITICAL FOR SAFETY, USE ONES DESCRIBED ON PARTS LIST ONLY.

MONITOR PCB

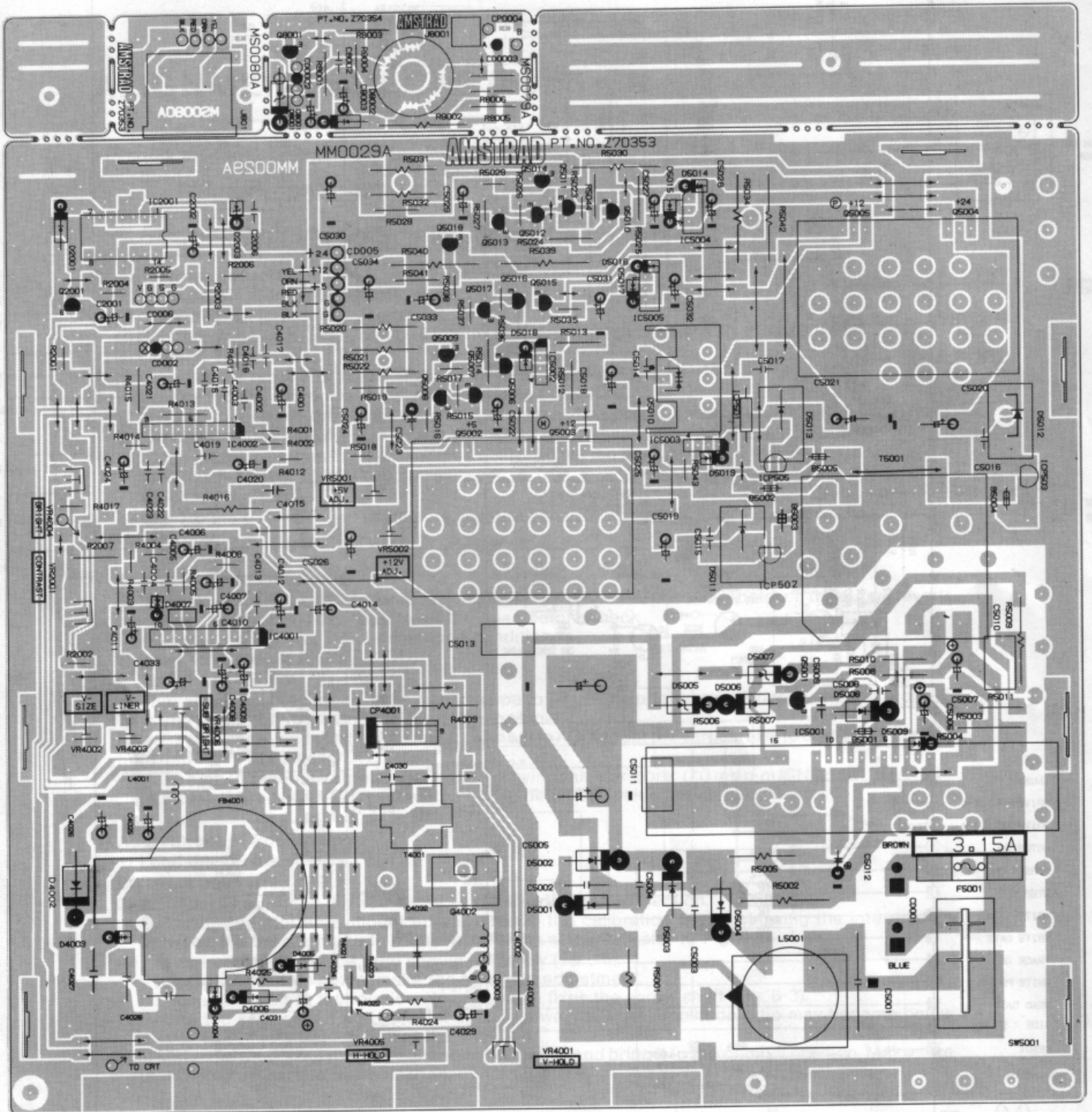

1) Load the CE Data to MEM CE3DD1.

2) Select track (Track 78) ~

3) Synchronize the probe of the oscilloscope by TPS or PCB and connect another probe to TP1. Set this probe ground to TP8, TP11 (ground). Set the input to AC, the vertical axis to 10mV/DIV, and the horizontal axis to 0.5ns/c/DIV. Make sure that the two external burst waveforms are smaller than the inside burst waveforms as shown in Fig. 5-3.

Note: Signal probe clip the waveform by the index wire.

If the waveform is still incorrect, replace the board assembly.

THE A-10 COMMAND SYSTEM UNIT IS MADE BY ANSTRAD

COMP. NO. 173000 FOR A013740

1-800-TEL-TRONIC-10 (3274-1001)

PRINTER PCB (TOP)

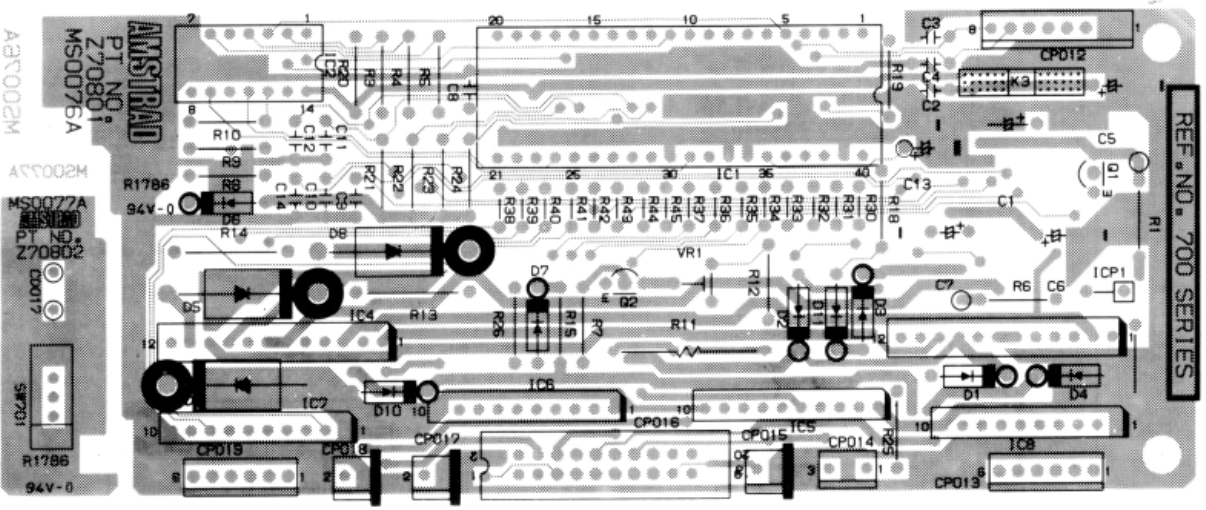

PRINTER PCB (BOTTOM)

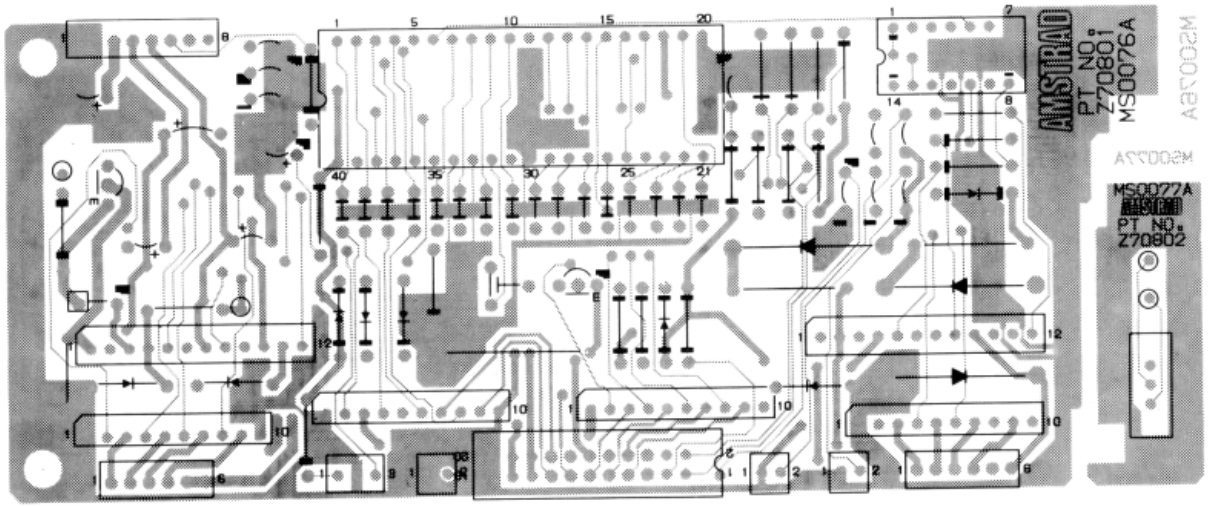

KEYBOARD PCB

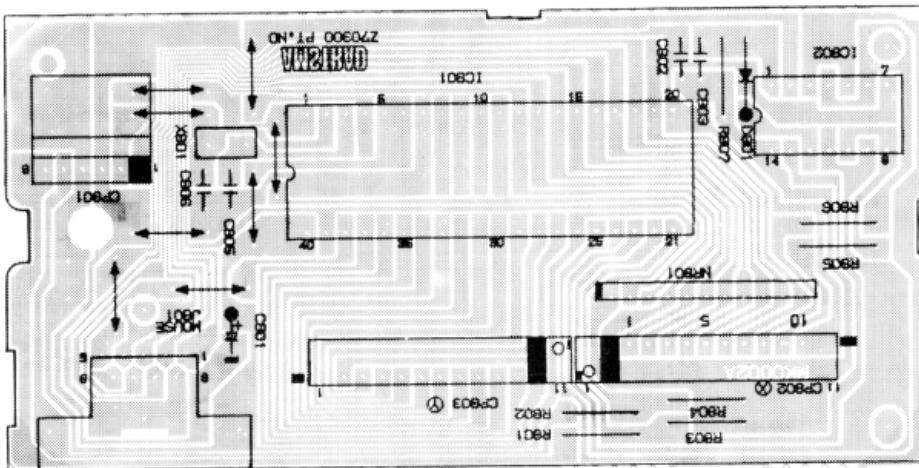



# POWER SUPPLY

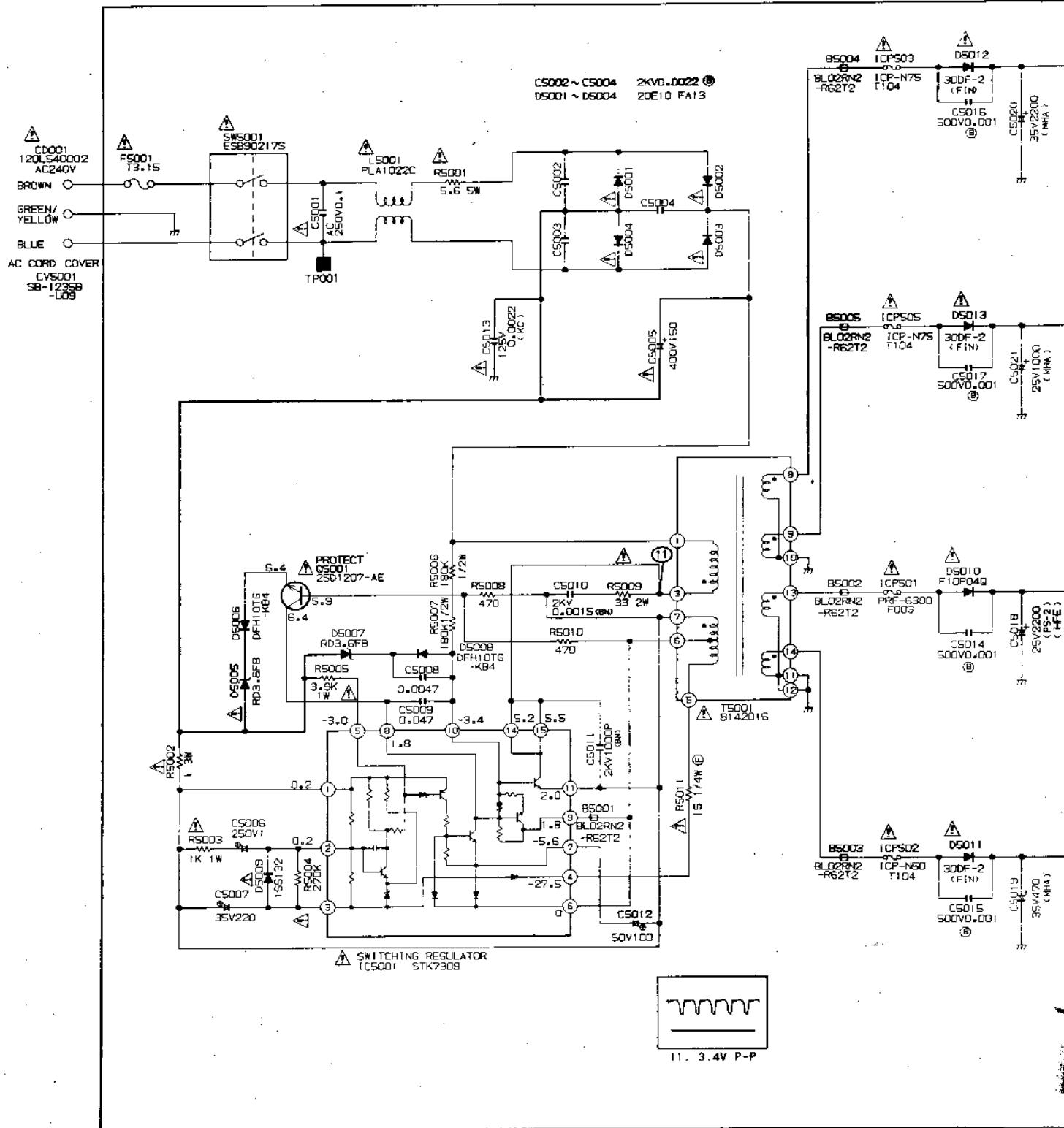

CAUTION: SINCE THESE PARTS MARKED BY ARE CRITICAL FOR SAFETY, USE ONES DESCRIBED ON PARTS LIST ONLY.

ATTENTION: LES PIÈCES RÉPARÉES PAR UN ÉTANT DANGEREUSES AU POINT DE VUE SÉCURITÉ N'UTILISER QUE CELLES DÉCRITES DANS LA NOMENCLATURE DES PIÈCES.

# CIRCUIT DIAGRAM

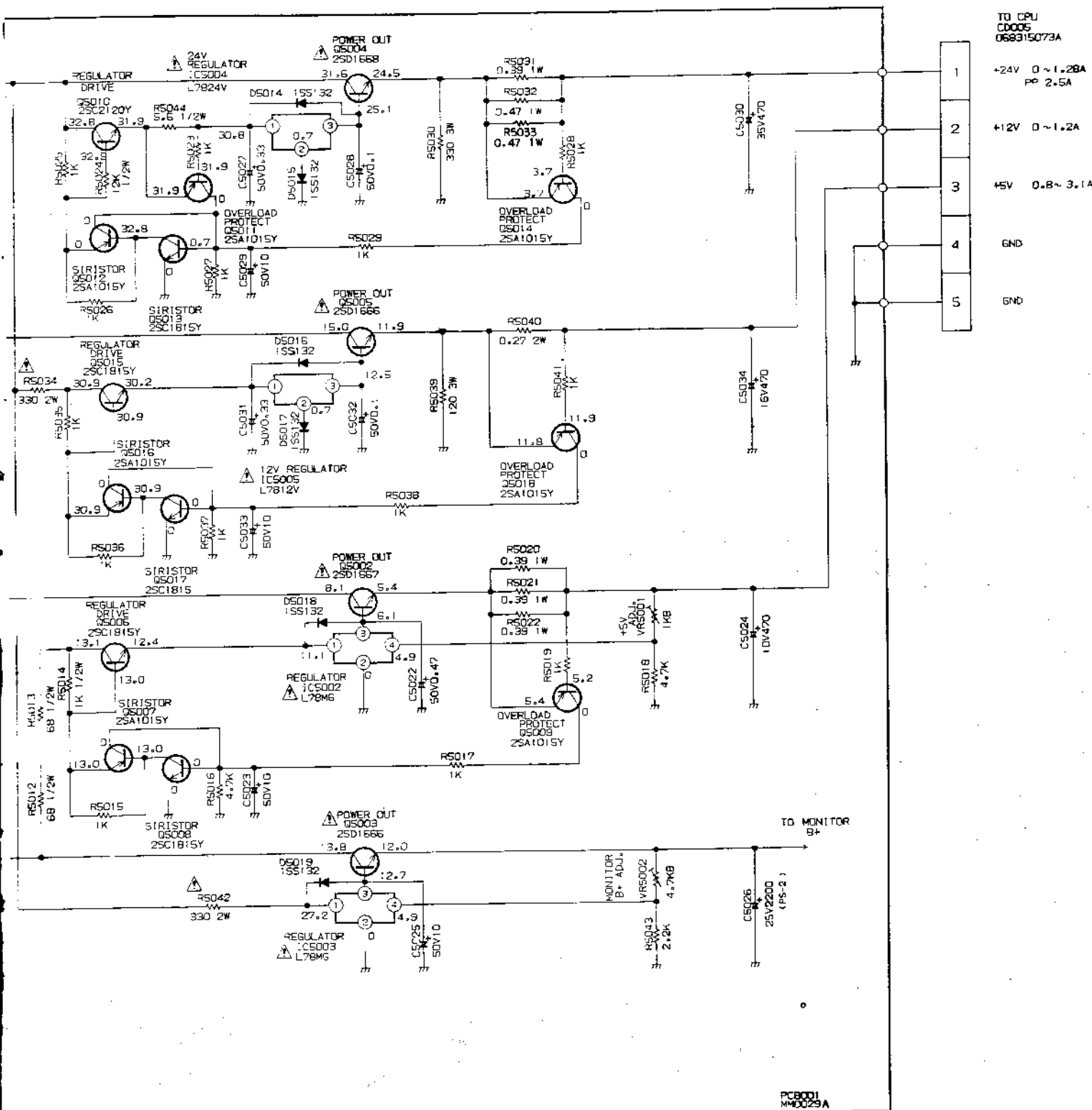

- TO CPU  
C5005  
068315073A
- 1 +24V 0 ~ 1.28A  
PP 2.5A
- 2 +12V 0 ~ 1.2A
- 3 +5V 0.8 ~ 3.1A
- 4 GND
- 5 GND

PC8001  
M00029A

NOTE: THIS SCHEMATIC DIAGRAM IS THE LATEST AT THE TIME OF PRINTING AND SUBJECT TO CHANGE WITHOUT NOTICE.

### CABINET PARTS LIST

Ref.	Description	Part No.
1	Front Cabinet	177017
2	Bottom Cabinet	177016
3	Top Cabinet	177009
4	Frame (L)	177020
5	Frame (R)	177021
6	PCB Support (L)	177022
7	Frame Support (R)	177023
8	FD-4 Floppy Disc Drive EME232W	177014
9	CPU PCB Ass'y	177007
10	Monitor PCB Ass'y	177006
11	Screw Caps	171363
12	Knob Volume	171362
13	Cowling Disc Drive	177024
14	Cowling Cover	177025
16	CRT M340AXBWDN	177026
17	Screw CRT Mount	
18	Spacers CRT Rubber	171022
19	Socket CRT	171469
20	Button Power On/Off	

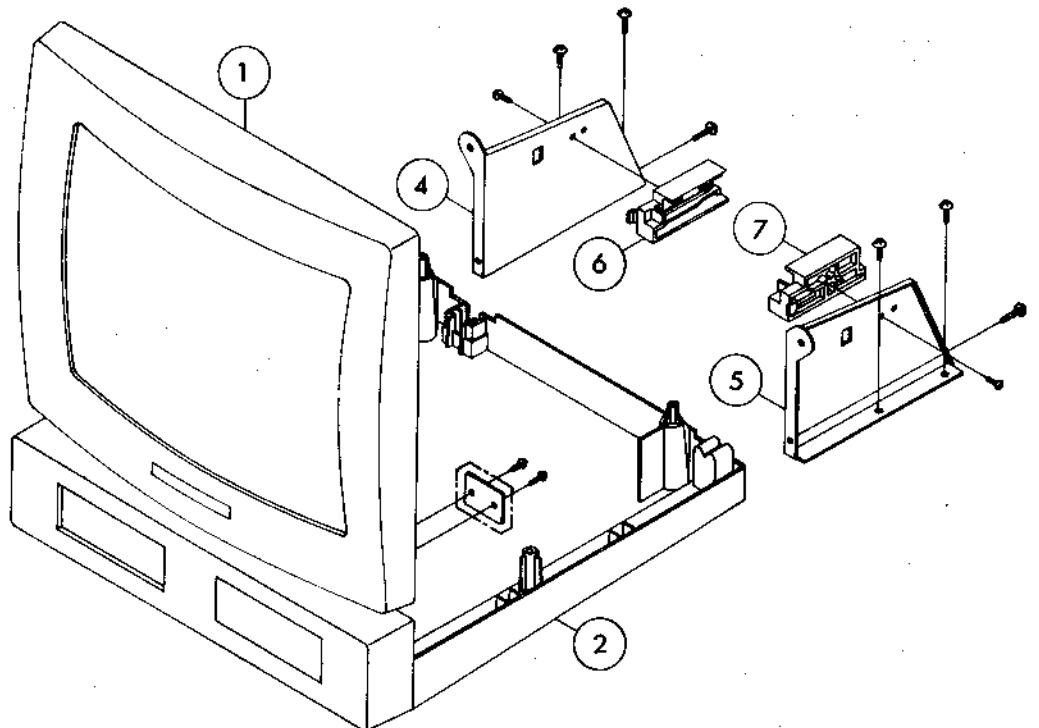
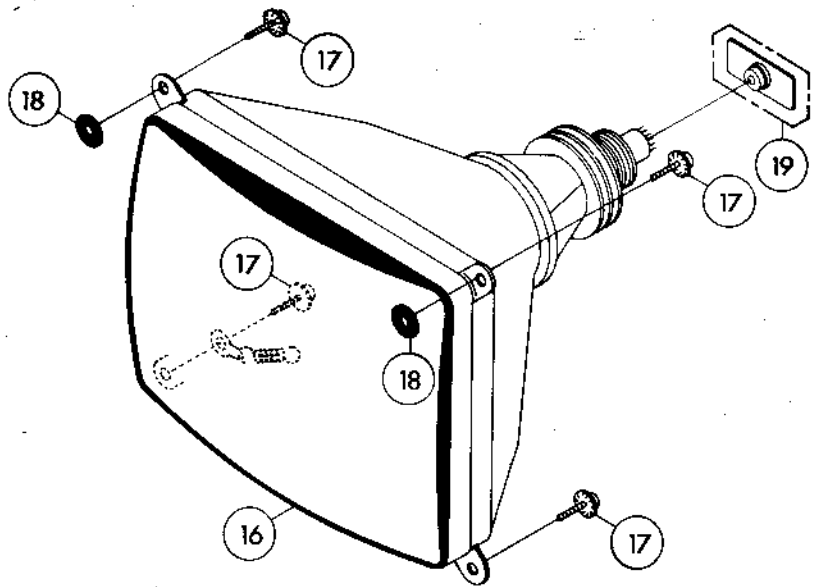

# MONITOR CABINET EXPLODED VIEW

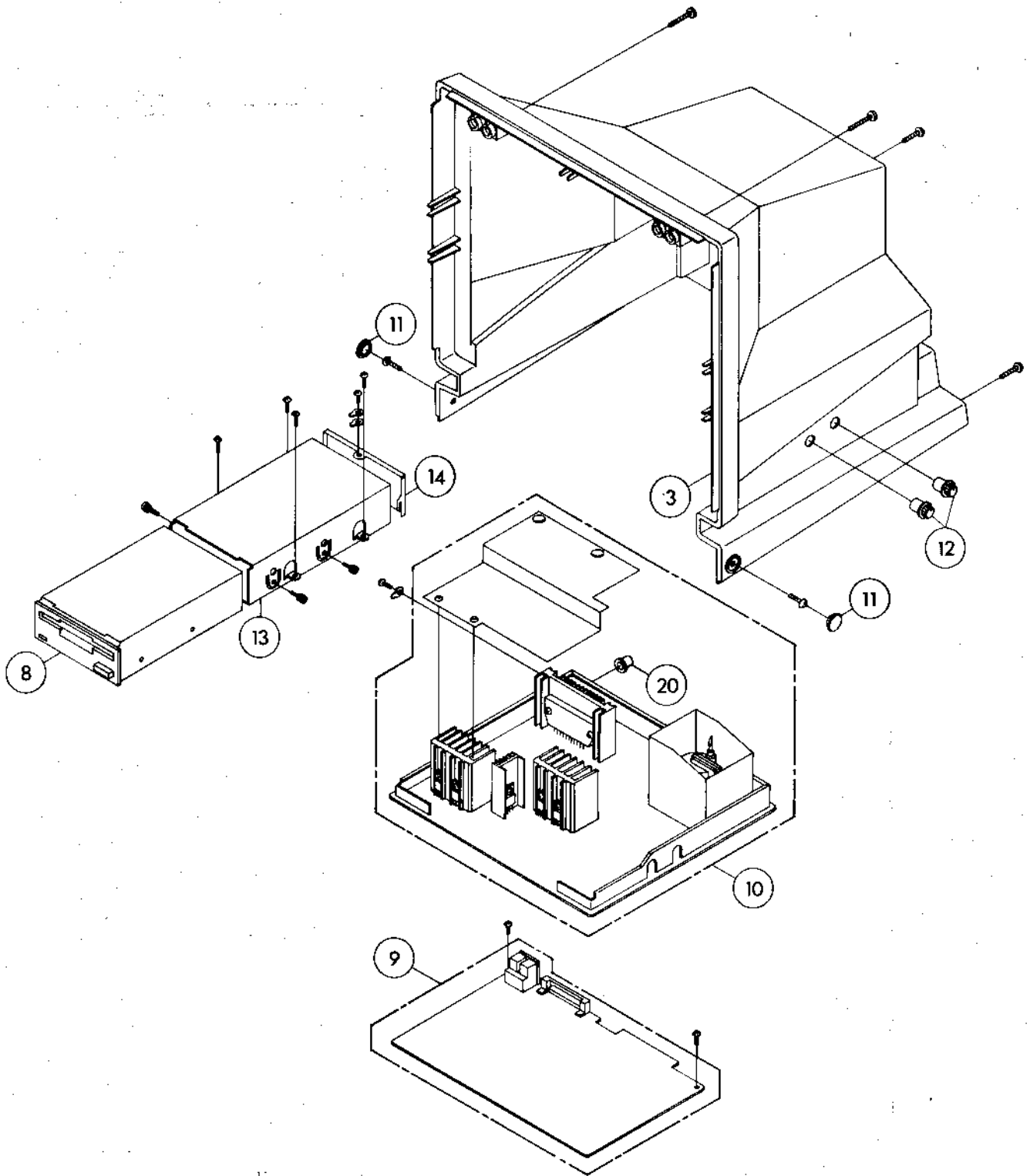

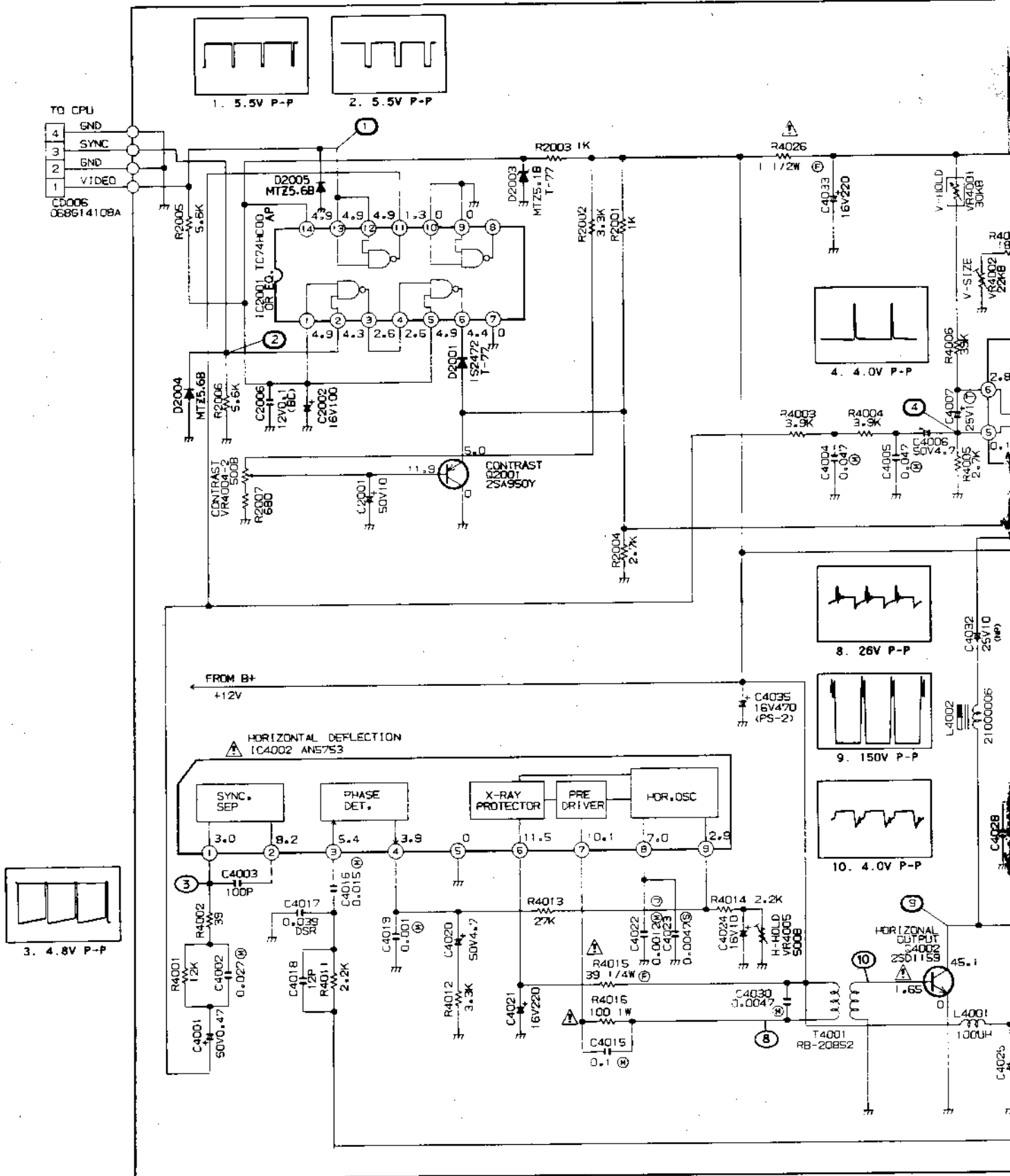

CAUTION SINCE THESE PARTS MARKED BY ARE CRITICAL FOR SAFETY USE ONES DESCRIBED ON PARTS LIST ONLY.

ATTENTION LES PIECES REPAREES PAR UN ETANT DANGEREUSES AN POINT DE VUE SECURITE N'UTILISER QUE CELLES DECRITES DANS LA NOMENCLATURE DES PIECES.

# SCHEMATIC DIAGRAM

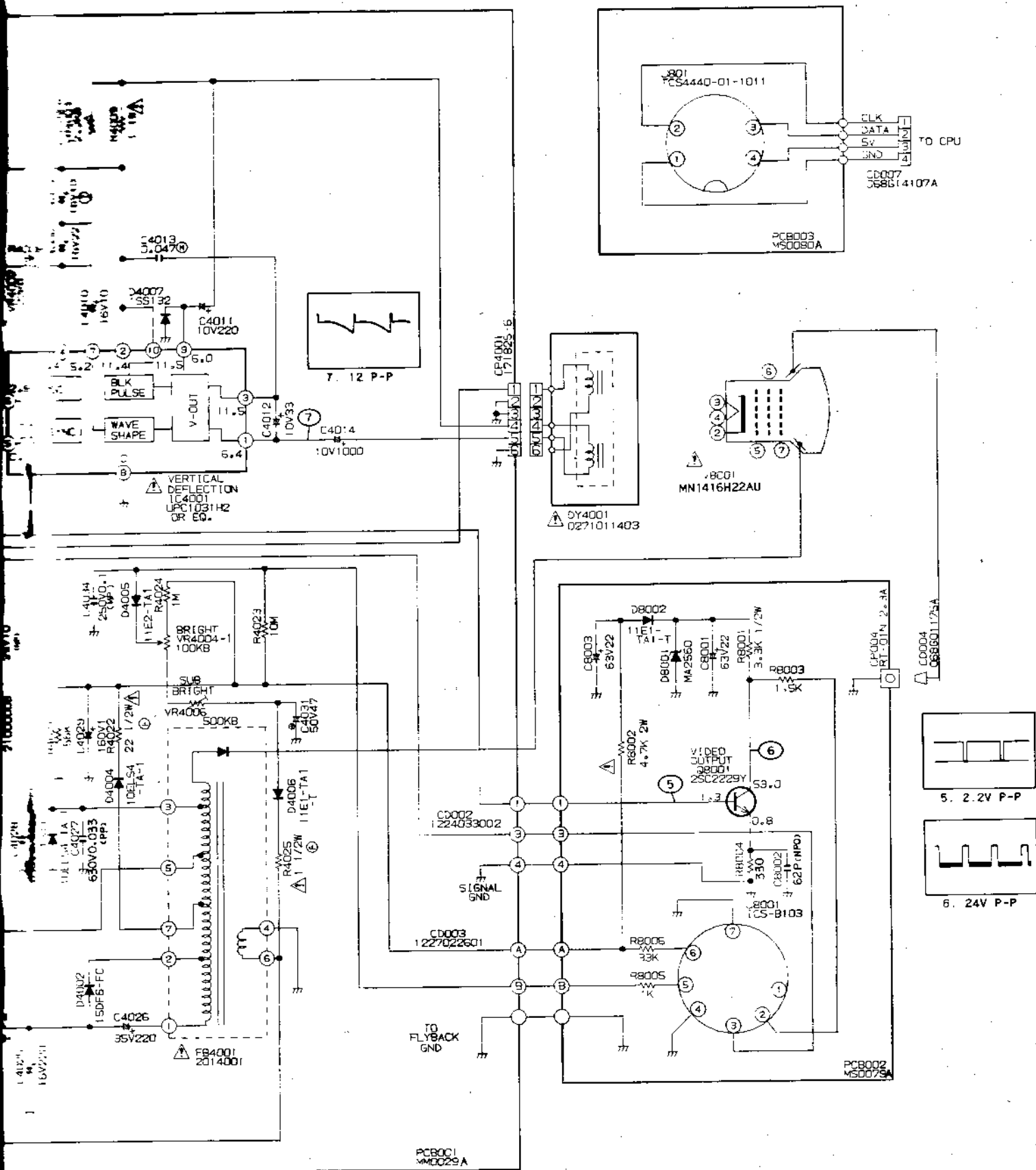

NOTE THIS SCHEMATIC DIAGRAM IS THE LATEST AT THE TIME OF PRINTING AND SUBJECT TO CHANGE WITHOUT NOTICE.

## KEYBOARD EXPLODED VIEW

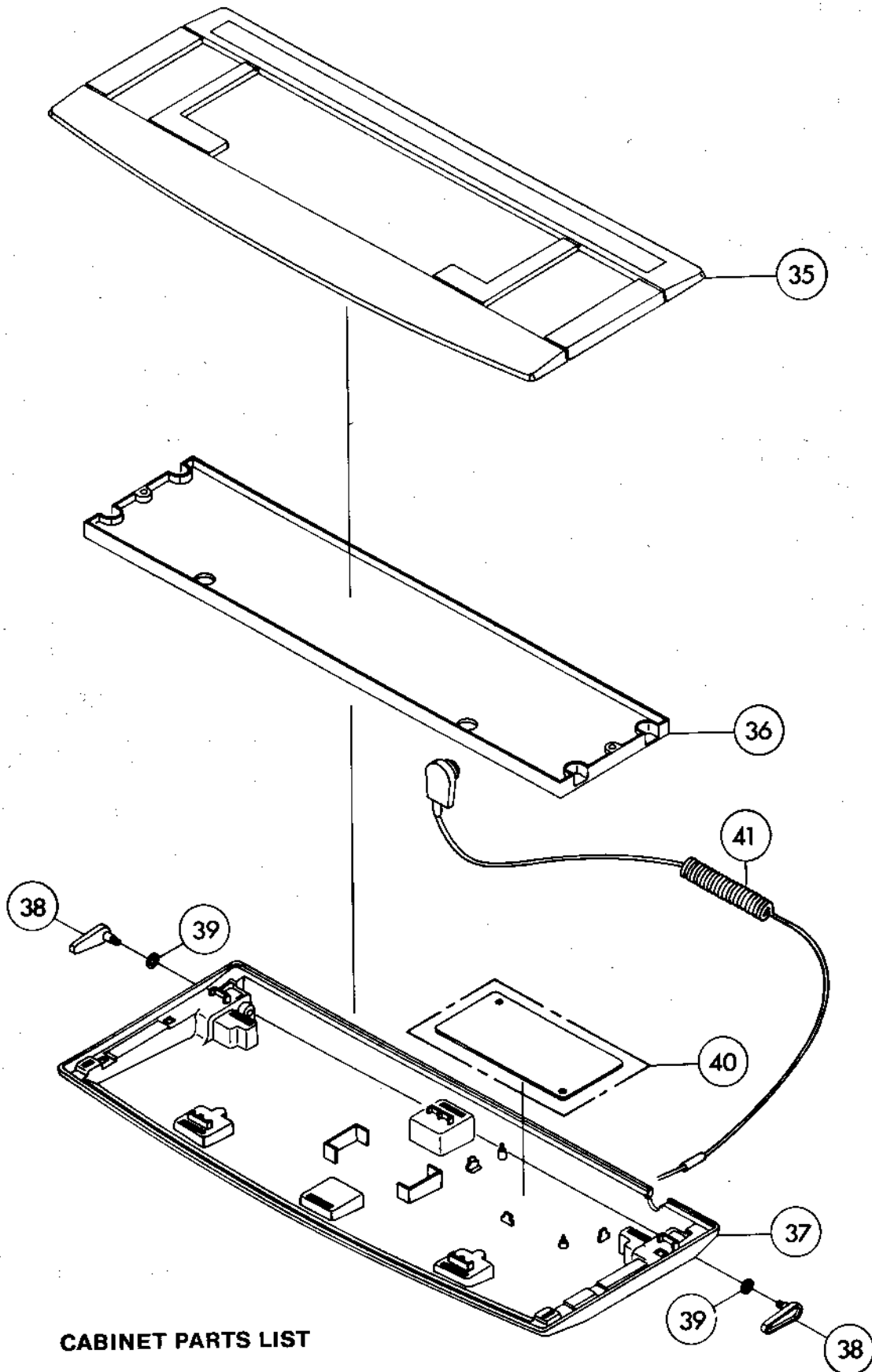

### CABINET PARTS LIST

Ref.	Description	Part No
35	Keyboard Top Cabinet	177001
36	Switch Ass'y Keyboard	177002
37	Keyboard Bottom Cabinet	177003
38	Stand Keyboard	171358
39	Washer	171659
40	Keyboard Controller PCB Ass'y	177005
41	DIN Cord Keyboard	177004

# PRINTER CABINET EXPLODED VIEW

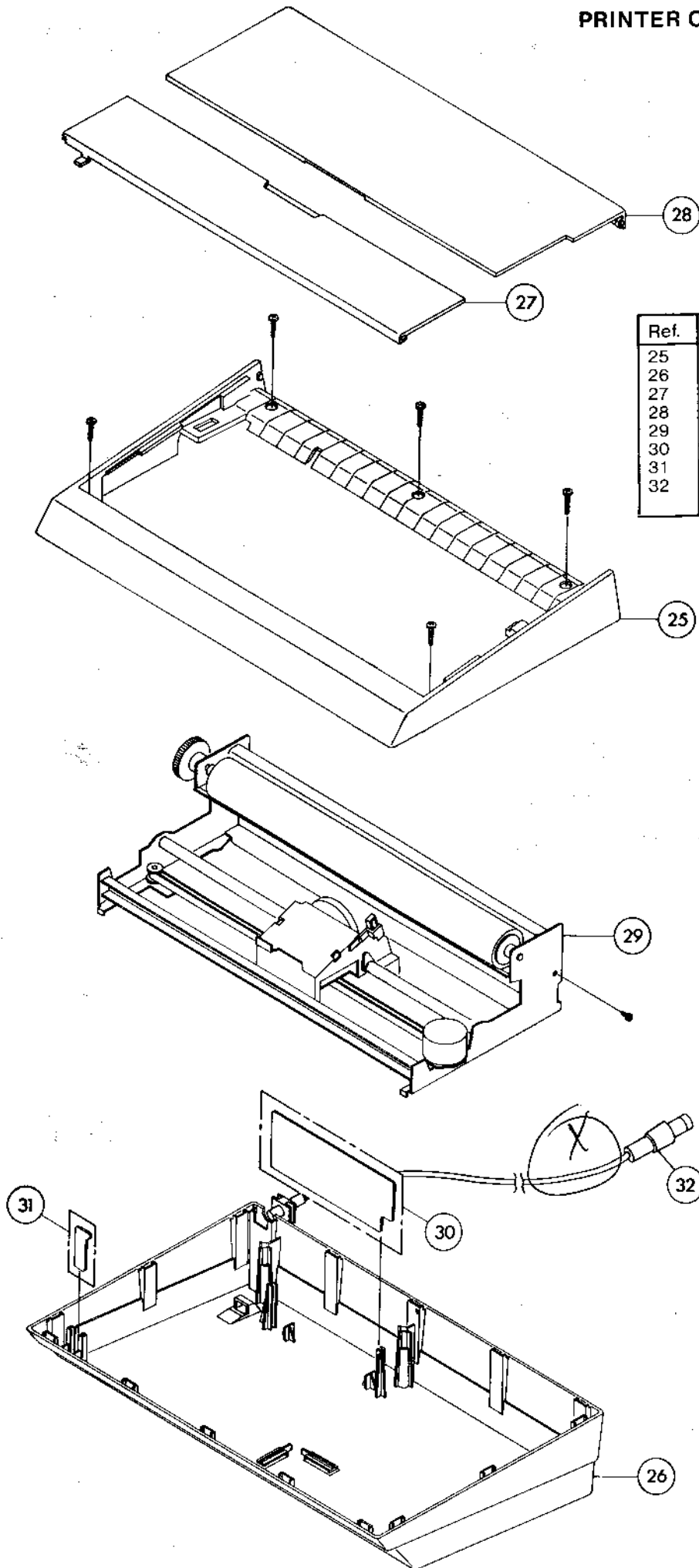

## CABINET PARTS LIST

Ref.	Description	Part No.
25	Top Cabinet Printer	177027
26	Bottom Cabinet	177028
27	Cushion	177029
28	Paper Tray	177030
29	Printer Mechanism Complete	177012
30	Printer Controller PCB Ass'y	177008
31	Leaf Switch	177031
32	DIN Cord Printer Tractor Feed Ass'y	177011 177018



# CPU PCB COMPONENT LAYOUT

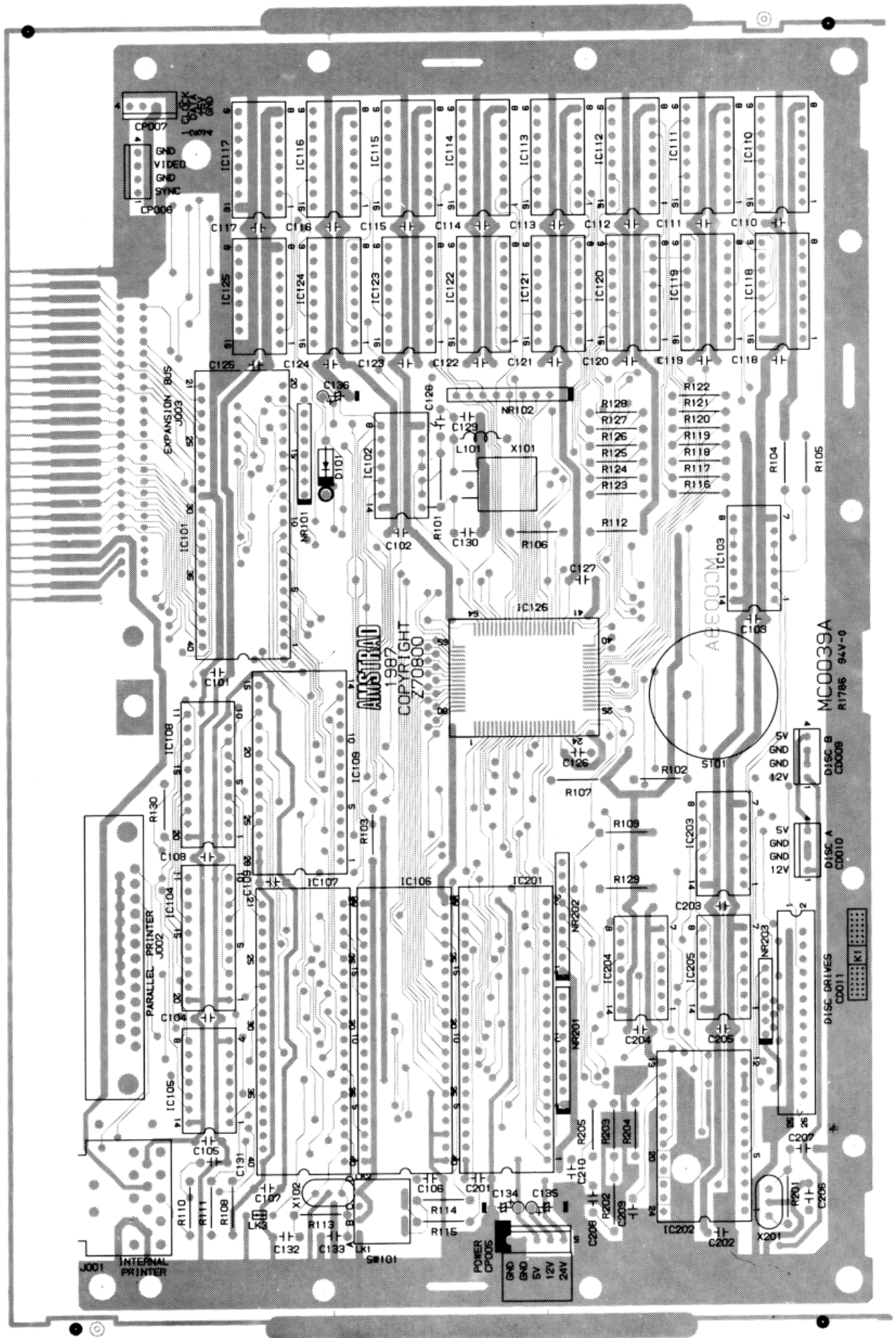

CPU PCB (REAR VIEW)

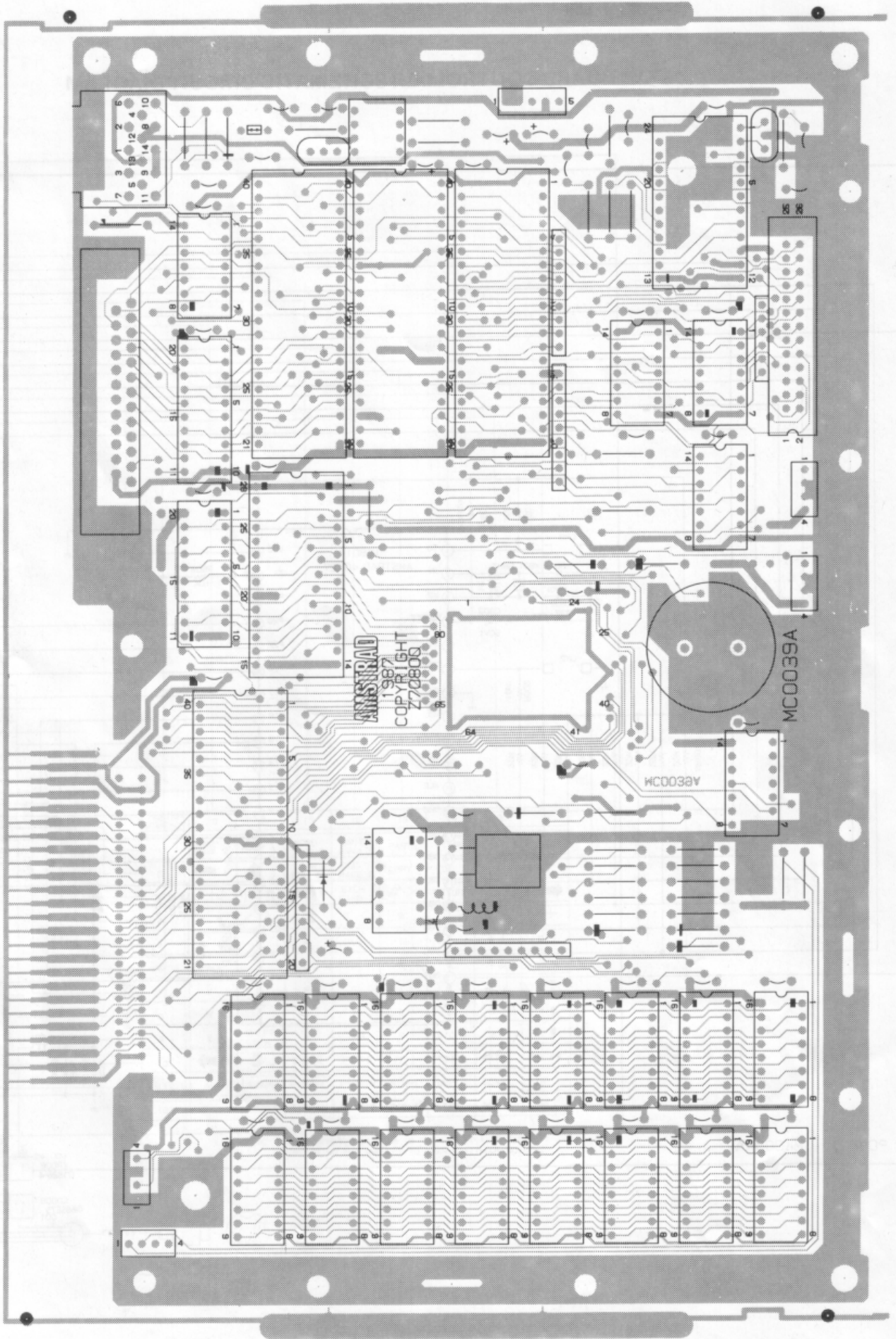

# KEYBOARD CONTROLLER SCHEMATIC CIRCUIT DIAGRAM

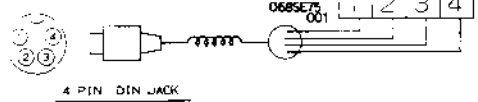
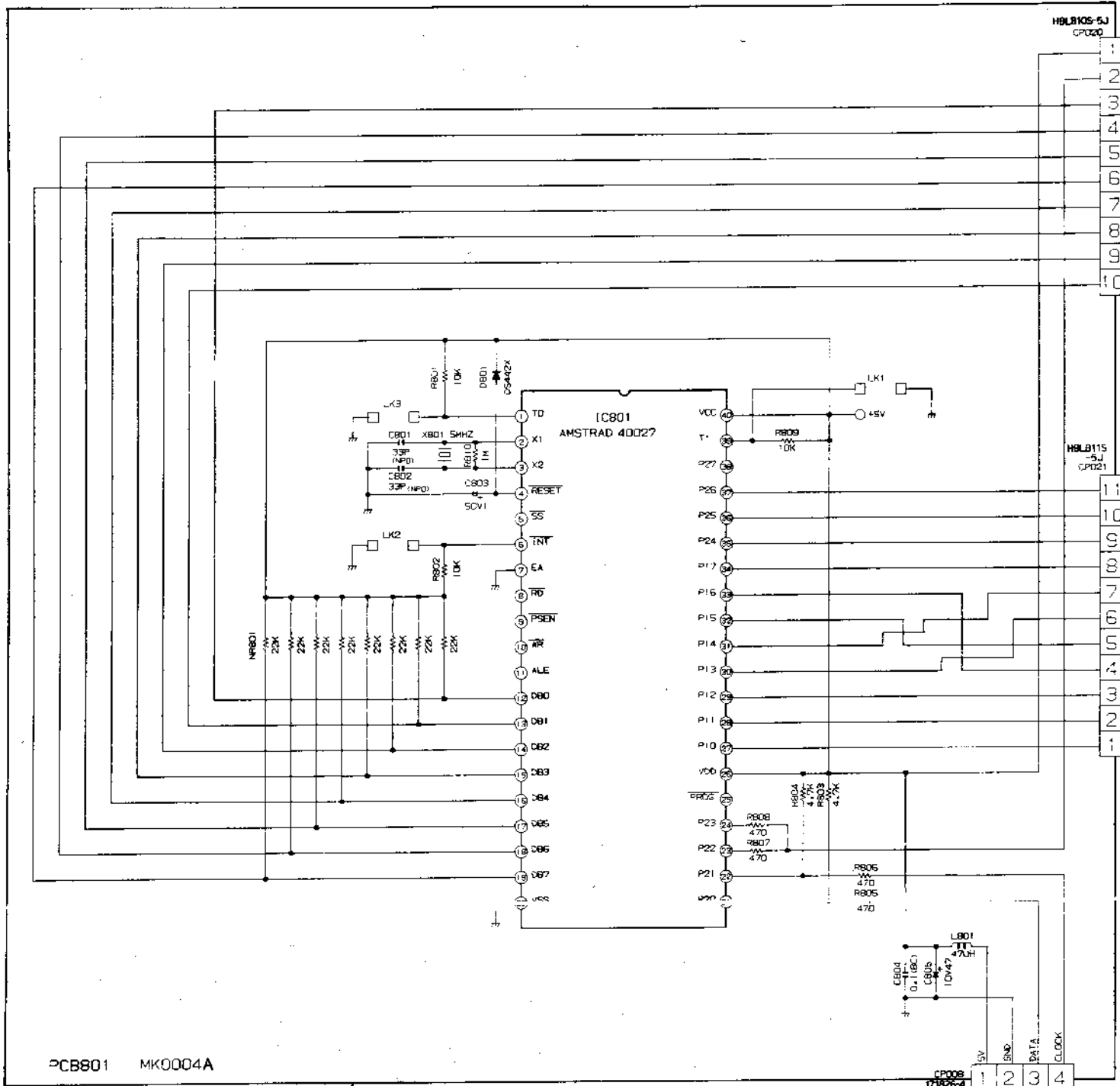

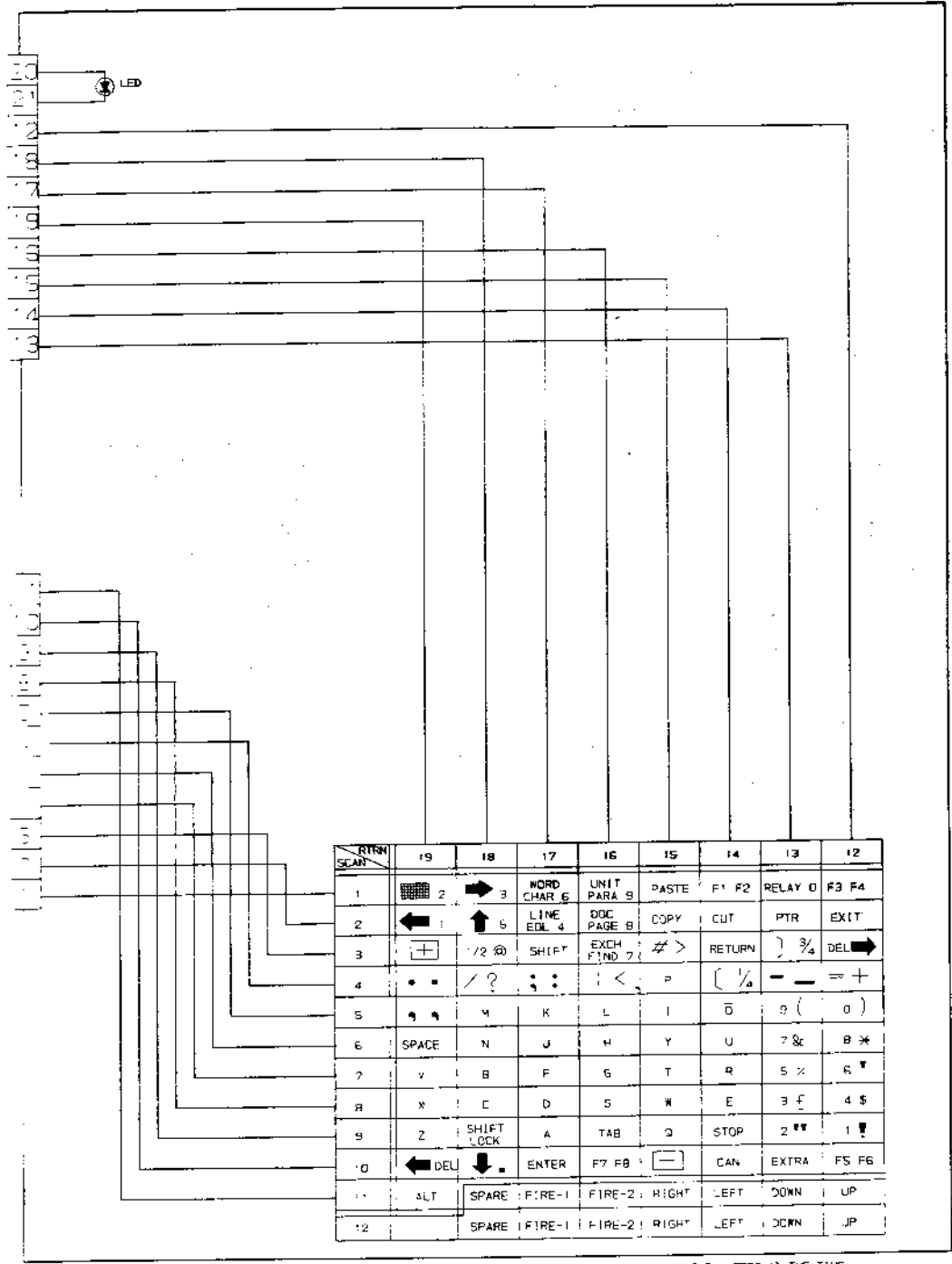

NOTE: THIS SCHEMATIC DIAGRAM IS THE LATEST AT THE TIME OF PRINTING AND SUBJECT TO CHANGE WITHOUT NOTICE.

SW801 ESU-24100

## ALIGNMENT CHART FOR THE MONITOR

Equipment required: Digital voltmeter; Oscilloscope; Frequency Counter; Test Pattern Generator; RP6 or Pattern Disc.

### ALIGNMENT INSTRUCTIONS

STEP	FUNCTION	SIGNAL IN	SIGNAL OUT	METHOD	REMARKS
1.	D.C. 12V Adjustment.	Pin 3/CD101	Pin 2/CD102	Adjust VR4004-1 to max. Adjust VR5002 to read 12V $\pm$ 0.05V.	Disconnect CD101 to perform the test.
2.	D.C. 5V Adjustment.	Pin 3/CD101.	Pin 3/CD102	Adjust VR4004-1 to max. Adjust VR5001 to read 5V $\pm$ 0.5V.	Disconnect CD101 to perform the test.
3.	V. Size Adjustment.	Pin 3/CD101.	Monitor Screen.	Adjust VR4002 for full size @ 0%.	Adjust Brightness control as required.
4.	V. Linearity Adjustment.	Pin 3/CD101	Monitor Screen.	Adjust VR4003 to get Up/Down space from the centre of the circle in the test pattern.	
5.	H. Hold Adjustment.	Free run no input.	Pin 1/CP4001	Adjust VR4005 to read frequency 15625kHz.	
6.	V. Size. V. Linearity.	Use RP6.	Monitor Screen.	Adjust VR4002 to get B1 & B2 = 10 $\pm$ 3mm. Adjust VR4003 to get A1 & A2 = 10 $\pm$ 3mm.	Refer to Fig. 1.
7.	Sub Brightness Adjustment.	Normal System Boot Up.	Monitor Screen.	Adjust VR4004-1 & VR4004-2 to max. Adjust VR4006 so the text appears dimly.	Test F & I Keys display.

### MAJOR COMPONENTS LOCATION GUIDE

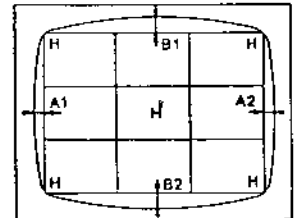
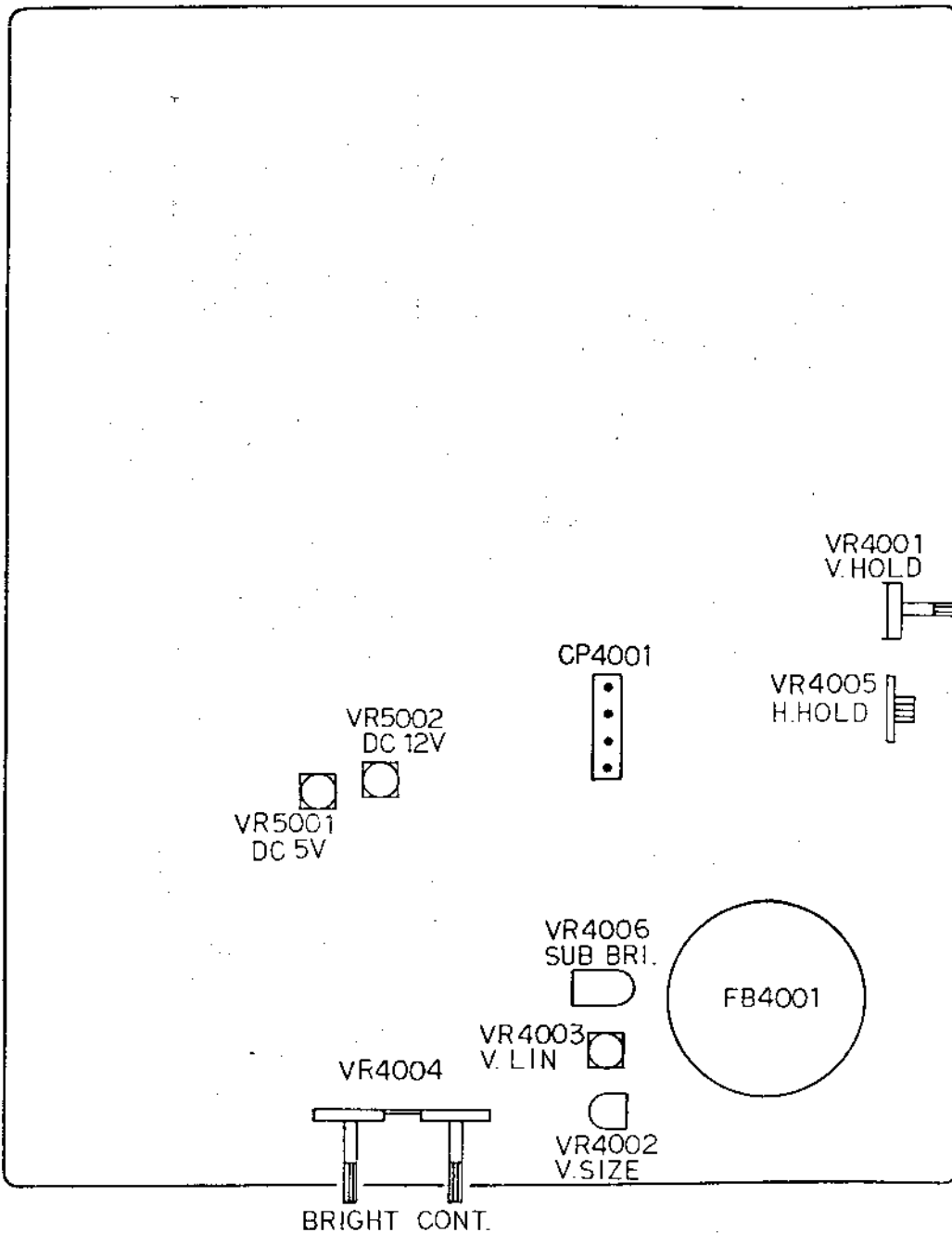























FIGURE 1

## ELECTRICAL PARTS LIST

All components shown with symbol  are safety critical and should be obtained direct from the manufacturers.

Ref.	Description	Part No.
<b>I.C.s</b>		
IC101	IC Z8400APS Z80A	40080
IC102	IC TC74HCU04AP	40008/A
IC103	IC TC74HC14AP	171033
IC104	IC HD74LS373	170108
IC105	IC HD7405P	177032
IC106	IC AMS40087	40087
IC107	IC UPD8039HLC	177033
IC108	IC TC74HCD373AP	177034
IC109	IC AMS40103	40103
IC110-125	IC UPD41257-15	171032
IC126	IC AMS40028	171031
IC201	IC Z765APS	40018
IC202	IC SED9420CAP	171034
IC203, 2001	IC TC74HC00AP	171035
IC204	IC TC74HC04AP	171037
IC205	IC TC74HC14AP	171033
IC701	IC AMS40088	40088
IC702	IC HD7406P	177036
IC703, 704	IC MP4504	177037
IC705-708	IC MP4002	177038
IC801	IC AMS40027	171043
IC4001	IC UPC1031H2	 177039
IC4002	IC AN573	 177040
IC5001	IC STK7309	 177041
IC5002, 5003	IC L78MG	 177042
IC5004	IC L7824V	 177043
IC5005	IC L7812V	 177044
<b>Transistors</b>		
Q701, 5007, 5009, 5011, 5012, 5014, 5016, 5018	TR 2SA1015Y-T1	 170453
Q702, 5006, 5008, 5013, 5015, 5017	TR 2SC1815Y	170447
Q2001	TR 2SA950Y	 170448
Q4002	TR 2SD1159	 171044
Q5001	TR 2SD1207-AE	 170451
Q5002	TR 2SD1667	177045
Q5003, 5005	TR 2SD1666	 171045
Q5004	TR 2SD1668	177046
Q5010	TR 2SC2120Y	170113
Q8001	TR 2SC2229Y-T6	171046
<b>Diodes</b>		
D101	D DS442X-BT	1422117
D102, 103	DZ GZ4.7Y	1422111
D701-704, 706, 707, 710, 4006, 8002	D 11E1TA1-T	171050
D705, 708, 709	D 30D-1 FC	170625
D711, 801	D DS442X-BT	1422111
D2001	D 1S2472T-77	170455
D2003	D Z MTZ5.1BT-77	171498
D2004, 2005	D Z MTZ5.6BT-77	171499
D4002	D 15DF6-FC	177048
D4003, 4004	D 10ELS4-TA-1	171550
D4005	D 11E2TA1	171049
D4007, 5009, 5014-5019	D 1SS132T-77	 171489
D5001-5004	D 20E10FA13	 171048
D5005, 5007	D Z RD3.6FB	 171458
D5006, 5008	D DFH10TG-KB4	171492
D5010	D S F10PO4Q	 171497
D5011-5013	D 30DF2-FIN	 171052
D8001	D Z MA2560	171054

Ref.	Description	Part No.
<b>Coils &amp; Transformers</b>		
L101	Coil 2.2uH TA	177049
L801	Coil 47uH	177050
L4001	Coil Inductor 100uH 1451MM	1400148
L4002	Coil Linearity 21000006	170631
L5001	Coil Line Filter AC PLA1022C	 177051
T4001	TX Horizontal Drive RB-20852	 170633
T5001	TX Switching 8142016	 177052
DY4001	Yoke Deflection	177053
FB4001	Transformer Fly Back 2014001	177054
<b>Jacks</b>		
J001	Jack DIN Printer	177055
J801	Jack DIN Keyboard	177056
J8001	Socket CRT	171022
<b>Switches</b>		
SW101	Switch Slide	177057
SW701	Switch Micor for Printer	177031
SW801	Switch Keyboard	177002
SW5001	Switch Power	 177058
<b>Variable Resistors</b>		
VR701	VRSF 2.2k ohm	177109
VR4001	VR Rotary 30k ohm	171024
VR4002	VRSF 22k ohm	177110
VR4003	VRSF 2.2k ohm	177111
VR4004	VR Rotary Brightness/Contrast Gang	177110
VR4005	VRSF 500ohm	171108
VR4006	VRSF 500k ohm	177113
VR5001	VRSF 1k ohm	177114
VR5002	VRSF 4.7k ohm	177115
<b>Cords</b>		
CD008	Cord DIN Keyboard	177004
CD701	Cord Connector Printer	177011
<b>PCB's</b>		
PCB101	PCB CPU MC0039A	177007
PCB001	PCB Monitor MM0029A-C	177006
PCB002, 003	Parts of PCB001	
PCB701	PCB Printer MS0076A	177008
PCN702	Part of PCB701	
PCB801	PCB Keyboard MK0004A	177005
<b>Protections </b>		
F5001	Fuse 3.15A(T)	171621
ICP501	IC Protector PRF-6300-F003	177059
ICP502	IC Protector ICP-N50T104	171547
ICP503, 504	IC Protector ICP-N75T104	171057
ICP701	IC Protector PRF-1600-F004	177060
<b>Resistor Networks</b>		
NR101	Resistor Network 6x1k ohm	177061
NR102, 201, 202	Resistor Network 8x1k ohm	171058
NR203	Resistor Network 5x680 ohm	177062
NR801	Resistor Network 8x220k ohm	177063
<b>Crystals &amp; Ceramic Resonators</b>		
X101	X'Tal HC-49/U 32.00MHz	171063
X102	COSC KBR-11.00MHz	171064
X201	COSC CSA16.00MX7	171231
X801	COSC KBR-5.0M	171232
<b>Miscellaneous</b>		
FD4	Compact Floppy Disc Drive EME-232	177014
PTR701	Printer Mechanism	177012
S101	Piezo Bleeper EFB-RD22C41A	177064
V8001	Tube CRT M340AXBWDN	177065

## ELECTRICAL PARTS LIST

Description	Circuit Ref.	Part No.
<b>Carbon Film Resistors</b> (All resistors are 1/4W unless stated otherwise)		
33ohm	R116-128	10019
39ohm	R4002	10018
82ohm	R106	10031
100ohm	R110, 111, 715, 719	10032
180ohm	R725, 726	10038
270ohm	R720, 723	10042
330ohm	R8004	10044
470ohm	R805-808, 5008, 5010	10048
560ohm	R102	10050
680ohm	R107, 2007	10052
1kohm	109, 707, 721, 2001, 2003, 5015, 5017, 5019, 5023, 5025-5029, 5035-5038, 5041, 8005	10061
1.5kohm	R204, 712, 8003	10065
2.2kohm	R103, 705, 710, 730-745, 4011, 4014, 5043	10069
2.7kohm	R2004, 4005	10068
3.3kohm	R2002, 4012	10073
3.9kohm	R4003, 4004	10075
4.7kohm	R112, 129, 703, 704, 708, 709, 803, 804, 5016, 5018	10077
5.6kohm	R2005, 2006	10079
6.8kohm	R2005	10081
10kohm	R114, 115, 130, 206, 702, 801, 802, 809	10085
12kohm	R4001	10087
18kohm	R4008	10091
27kohm	R4013	10095
33kohm	R203, 8006	10097
39kohm	R4006	10099
47kohm	R108, 716, 722, 724	10101
56kohm	R4021	10103
68kohm	R202	10105
100kohm	R104, 105	10109
270kohm	R5004	10119
1Mohm	R101, 113, 201, 810, 4024	10147
10Mohm	R4023	171065
1ohm/1/2W	R701	177129
5.6ohm/1/2W	R5044	177130
27ohm/1/2W	R706	177131
68ohm/1/2W	R5012, 5013	171067
1kohm/1/2W	R5014	1400165
12kohm/1/2W	R5024	177132
33kohm/1/2W	R8001	177133
180kohm/1/2W	R5006, 5007	171068
<b>Metal Oxide Resistors</b>		
0.22ohm/1W	R5032	171585
0.27ohm/2W	R5040	171071
0.39ohm/1W	R5020-5022, 5031	177134
1ohm/1W	R4009	171069
1ohm/2W	R711	177135
1ohm/3W	R5002	171077
3.3ohm/2W	R713	177136
18ohm/2W	R714	177137
33ohm/2W	R5009	171074
100ohm/1W	R4016	171589
120ohm/3W	R5039	177138
330ohm/2W	R5034, 5042	171075
330ohm/3W	R5030	177139
560ohm	R4027	177140
1kohm/1W	R5003	171070
3.9kohm/1W	R5005	170407
4.7kohm/2W	R8002	171076
<b>Fuse Type Resistors</b>		
1ohm/1/2W	R4025, 4026	171639
15ohm/1/4W	R5011	171078
22ohm/1/2W	R4022	171079
39ohm/1/4W	R4015	171080

Description	Circuit Ref.	Part No.
<b>Cement Type Resistors</b>		
5.6ohm/5W	R5001	1422138
<b>Ceramic Capacitors</b>		
7pF NPO	C206, 207	177141
10pF NPO	C130	177142
12pF	C4018	809251
22pF NPO	C129	177143
33pF NPO	C132, 133, 801, 803	150489
62pF NPO	C8002	177145
100pF	C708-712, 714, 4003	1422144
330pF	C131	150518
680pF	C131, 703, 704	806223
2200pF	C5013	171081
0.001uF/500V	C5014-5017	171082
0.001uF/2kV	C5011	1422147
0.0015uF/2kV	C5010	171083
0.0022uF/2kV	C5002-5004	1400223
0.01uF	C128	1400215
0.047uF	C5009	24015
0.1uF	C101-127, 201-205, 702, 804, 2006	171084
<b>Electrolytic Capacitors</b>		
0.1uF/50V	C5028, 5032	177146
0.33uF/50V	C5027, 5031	171086
0.47uF/50V	C4001, 5022	150909
1uF/50V	C803	20062
1uF/160V	C4029	1422151
1uF/250V	C5006	1400152
4.7uF/50V	C4006, 4020	1400240
10uF/16V	C135, 713, 4010, 4024	20024
10uF/25V	C4032	20037
10uF/50V	C2001, 5023, 5025, 5029, 5033	1400242
22uF/16V	C4008	20025
22uF/63V	C8001, 8003	170609
33uF/10V	C4012	170610
47uF/10V	C134, 136, 805	1400244
47uF/50V	C4031	171088
100uF/16V	C2002	20028
100uF/50V	C5012	171089
150uF/400V	C5005	177147
220uF/10V	C4011	170611
220uF/16V	C4021, 4025, 4033	20029
220uF/35V	C4026, 5007	20055
470uF/10V	C5024	20031
470uF/16V	C4035, 5034	1400248
470uF/35V	C5019, 5030	171091
1000uF/10V	C4014	800372
1000uF/16V	C705	1400158
1000uF/25V	C706, 5021	177148
1000uF/35V	C707	1422159
2200uF/25V	C5018, 5026	177149
2200uF/35V	C701, 5020	1422160
<b>Polyester Capacitors</b>		
0.001uF	C208, 4019	171093
0.0012uF	C4022	177150
0.0047uF	C403	177151
0.01uF	C210	171236
0.015uF	C4016	177152
0.027uF	C4002	177153
0.039uF	C4017	177154
0.047uF	C209, 4004, 4005, 4013	170422
0.1uF	C4015	177155
<b>Tantalum Capacitors</b>		
1uF/25V	C4007	171100
10uF/16V	C4009	1422167
<b>Polypropylene Capacitors</b>		
0.0022uF/630V	C4028	177156
0.033uF/630V	C4027	177157
<b>Styrol Capacitors</b>		
4700pF	C4023	177158
<b>Metal Polyester Capacitors</b>		
0.1uF/250V	C4034	177159
<b>Metal Polypropylene Capacitors</b>		
0.1uF/250V AC	C5001	177160

## PRINTER MECHANISM PARTS LIST

Ref.	Description	Part No.
<b>Chassis &amp; Carriage Drive</b>		
1, 4	E Ring E-7	177081
2	Nut M3	177082
3	Hex Head Screw	
5	Main Rail Shaft	177083
6	Nut M4	177084
7	Frame Side Boss	
8	Frame Side Rubber	
9	Frame Set Rubber	
10	Chassis Complete	177085
11	Carrier Drive Pulley	
12	Idle Pulley Flange	
13	Carrier Drive Base	
14	Drive Shaft Bracket	
17	Carrier Motor Ass'y	177086
19	E Ring E-3	
20	Idle Pulley	
21	Idle Pulley Spacer	
22	Idle Pulley Bracket	
23	Hexagon Head Screw M4 x 6	
24	Hexagon Head Screw M4 x 8	
25	Drive Belt	
26	Belt Holder	
27	Belt Holder Screw	
28	Drive Belt Complete	177087
<b>Paper Feed</b>		
1	Platen	177088
2	Set Screw	177047
3	Idle Gear Collar	
4	Index Idle Gear	
5	Washer	
6	Hexagon Head Screw	
7	Platen Knob	177089
8	Platen Gear	177090
9	Flange Screw	177091
10	Wheel Reset Stopper	
11	Index Motor Ass'y	177092
12	Release Shaft Bracket	
13	Paper Guide A	177117
14	Paper Guide B	177118
15	Feed Roller Holder	
16	Feed Roller Front	177119
17	Feed Roller Rear	177120
18	E Ring E-2.5	
19	Bail Arm Latch Spring	177093
20, 29	Screw M3 x 4	
21, 34	Screw M2.6 x 5	
22	Paper Injector Switch Ass'y	177094
23	E Ring E-5	
24	Paper Release Screw	
25	Paper Release Lever	
26	Lever Cap	
27	Release Shaft Spring	
28	Paper Release Shaft	177095
30	Nylon Washer as required 0.3 - 0.5	
31	Paper Bail Arm Right	
32	Bail Arm Screw	
33	Injector Switch Lever	
35	Bail Arm Spring	
36	Paper Scale Roller	177121
37	Roller Spring	
38	Paper Bail	
39	Paper Bail Arm Left	177122
40	Feed Roller Set	177096

Ref.	Description	Part No.
<b>Tractor</b>		
1	Tractor Roller	177123
2	Tractor Spring	
3	Tractor Cover Right	
4	Tractor Frame Right	
5	Guide Roller	177124
6	Tractor Shaft	
7	Tractor Frame Left	
7	Tractor Frame Left	
8	Tractor Cover Left	
9	Tractor Gear	
10	Nylon Washer 4.2 x 8 x 0.3	
11	Tractor Gear Cover	
12	E Ring E-3	
13	Tractor Idle Gear	
14	Tractor Housing	
15	Tractor Pin	
16	Nut	
17	Tractor Ass'y Complete	177018
<b>Paper End Sensor</b>		
1	Screw	
2	Sensor Release Arm	
3	Spring	
4	Set Lever Screw	
5	Spring	
6	Paper End Lever	
7	Paper End Sensor PCB Ass'y	177125
8	Paper End Bracket	
9	Screw	
10	Paper End Sensor Ass'y	177097
<b>Carrier Frame</b>		
1	Cassette Base Screw A	
2	Screw M3.5 x 6	
3	Carrier Guide Base	
4	Carrier Guide	
5	E Ring E-4	
6	Carrier Guide Bracket	
7	Flange Screw M3.5 x 4	
8	Screw M3 x 4	
9	Carrier Metal	
10	Flange Screw M3 x 4	
11	Carrier Frame	
12	Screw M3 x 4	
13	Locator Bracket	
14	Felt Ring	
15	Screw M3 x 3	
16	Line Locator	
17	Cable Holder	
18	Carrier Lock Bracket	
19	Carrier Earth Blade	
20	Carrier PCB Ass'y	177126
21	Carrier Frame Ass'y	177098
22	Carrier Guide Base Complete	177099



### PRINTER MECHANISM PARTS LIST

Ref.	Description	Part No.
<b>Print Head and Hammer Drive</b>		
1	Screw M3 x 4	
2	Hammer Drive Base	
3	Spring	
4	Armature ←	
5	E Ring E-2.5	
6	Screw	
7	Spring Washer	
8	Hammer Magnet Ass'y ←	<del>177100</del>
9	Hammer Magnet Spacer	A
10	Print Head Base	
11	Hammer Screw	
12	Nut M3.5	
13	Hexagon Head Screw M3 x 6	
14	Spring	
15	Wheel Holder Complete	
16	Set Screw M4 x 4	
17	Hammer	
18	Selection Sensor Ass'y	177101
19	Hammer Stop Rubber	
20	Hammer Stop Arm	
21	Stop Arm Screw	
22	Spring	
23	Guard Balance Spring	
24	Selection Motor Ass'y	177102
254	Hammer Drive Base Ass'y	177103
26	Print Head Base Ass'y	177104
<b>Wheel Set/Release</b>		
1	Spring	
2	Guard Lock Plate	
3	Lever Cap	
4	Set Lever Screw	
5	Wheel Set Lever	
6	Spring	
7	Set Arm Screw	
8	Spring	
9	Wheel Set Arm	
10	Main Wheel Guard	
11	Wheel Reset Spring	
12	Sub Wheel Guard	
13	Spring	
14	Reser Plate Screw	
15	Wheel Reset Plate	
16	E Ring E-3	
17	Screw M3 x 3	
18	Wheel Set Ass'y	177105

Ref.	Description	Part No.
<b>Ribbon Drive</b>		
1	Feed Stem Plate	
2	Feed Stem Spring	
3	Spring Pin	
4	Ribbon Feed Stem	
5	E Ring E-2.5	
6	Carrier Reset Crank	
7	Spring	
8	Spring	
9	Reset Crank Lever	
10	Screw M2 x 8	
11	Leaf Switch Ass'y	177127
12	Ribbon Motor Ass'y	177106
13, 19	Screw M3 x 4	
14	Ribbon Feed Ratchet	
15	Spring	
16	Ribbon Feed Pawl	
17	Ribbon Feed Gear	
18	E Ring E-3	
20	Ribbon Gear Cover	
21	Feed Idle Gear	
22	Ribbon Drive Base	
23	Ribbon Feed Stem Complete	
24	Ribbon Main Gear Complete	
25	Ribbon Drive Base Complete	177107
<b>Ribbon Cassette Base</b>		
1	Cassette Holder Spring	
2	Ribbon Cassette Base	
3	Ribbon End Sensor Ass'y	177128
4	Ribbon End Bracket	
5	Screw	
6	Ribbon Cassette Base Ass'y	177108
<b>Accessories</b>		
1	Print Wheel	177013
2	Multi Strike Cassette Ribbon	177161

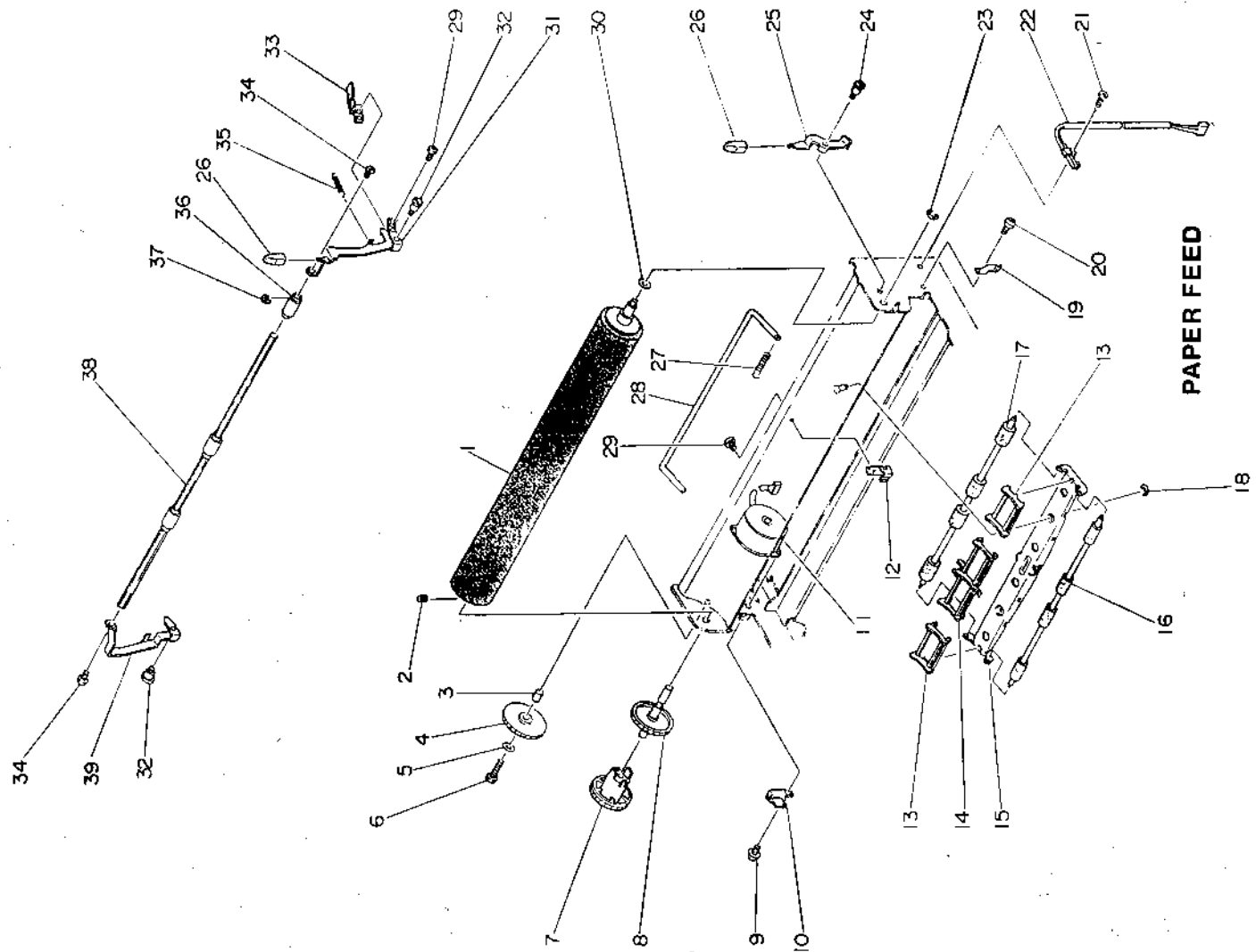

PAPER FEED

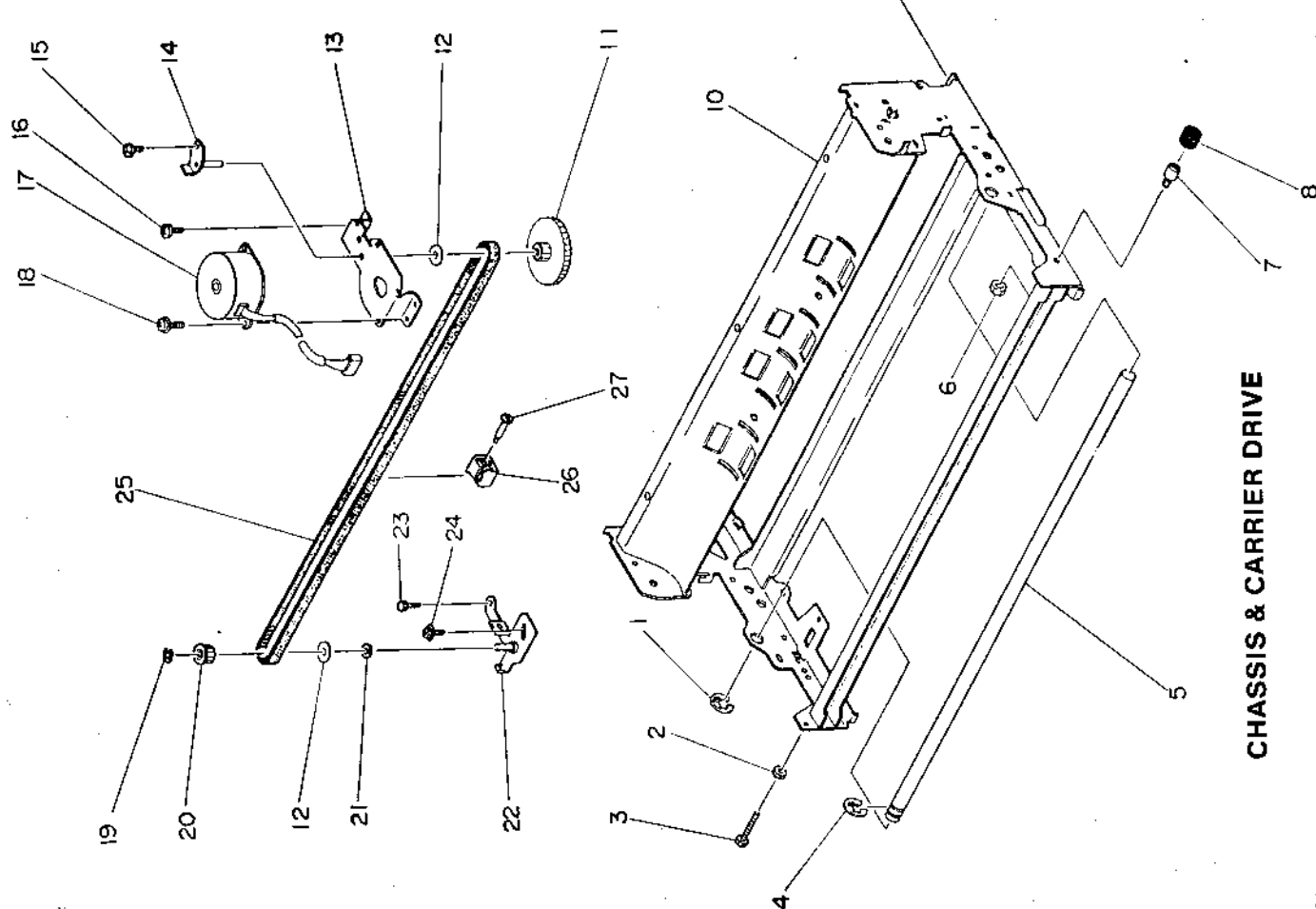

CHASSIS & CARRIER DRIVE

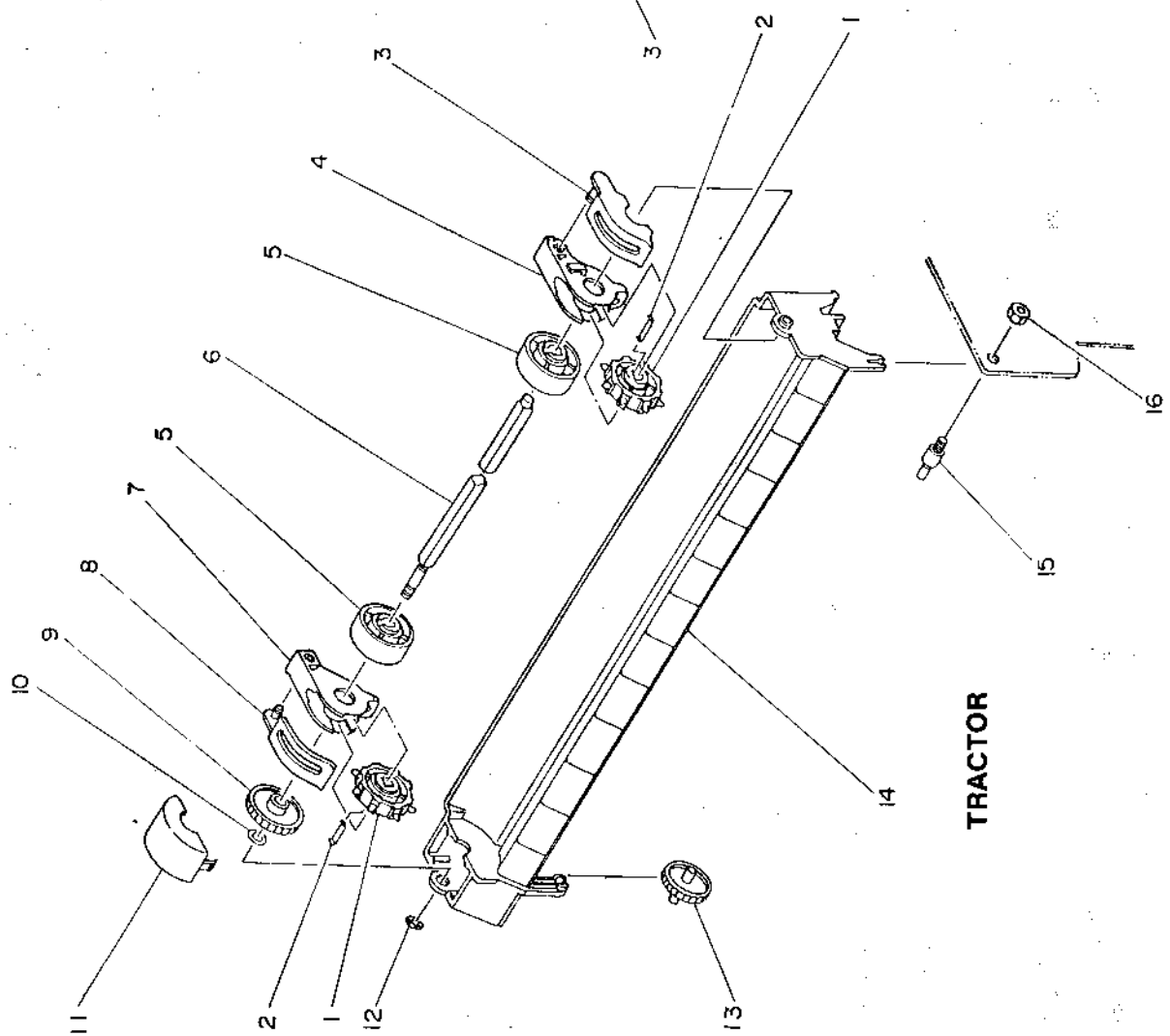
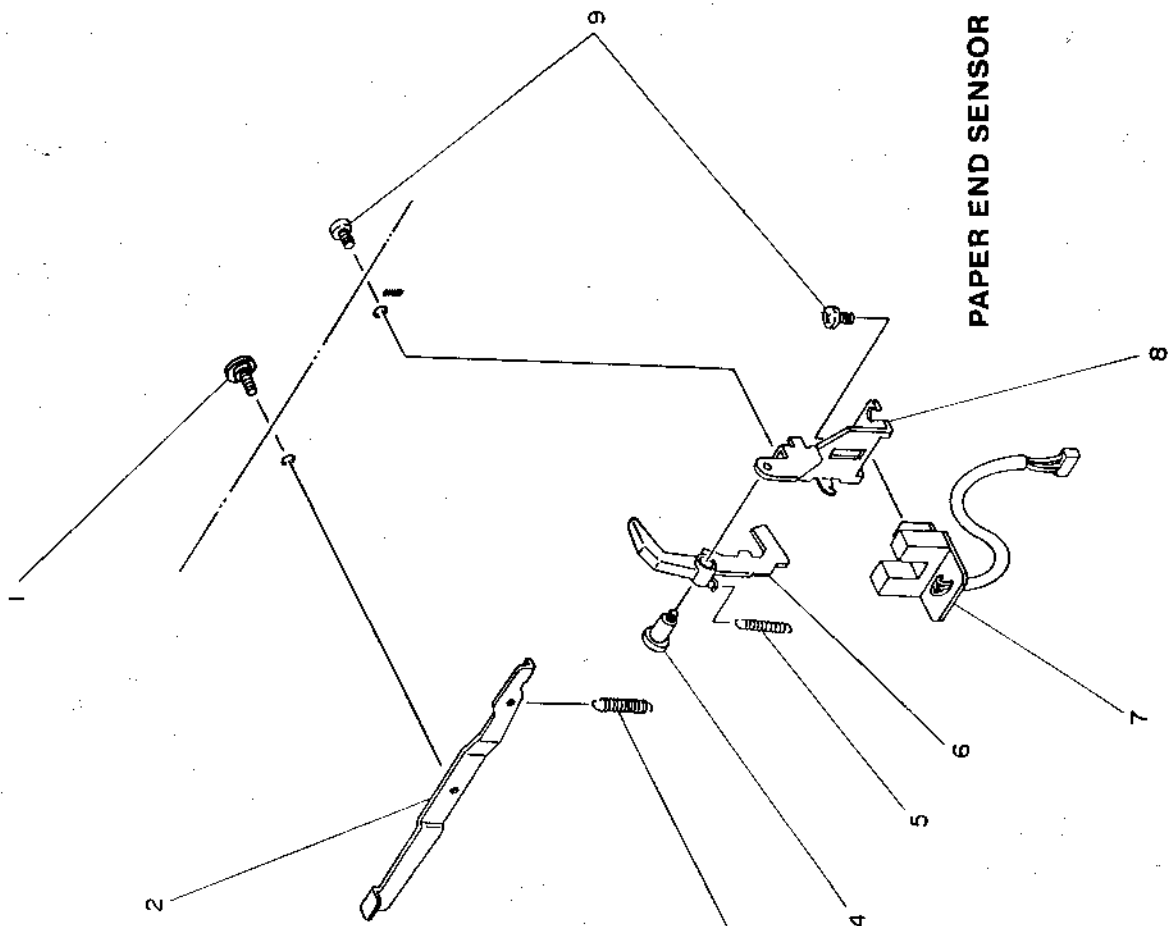

PRINT HEAD & HAMMER DRIVE

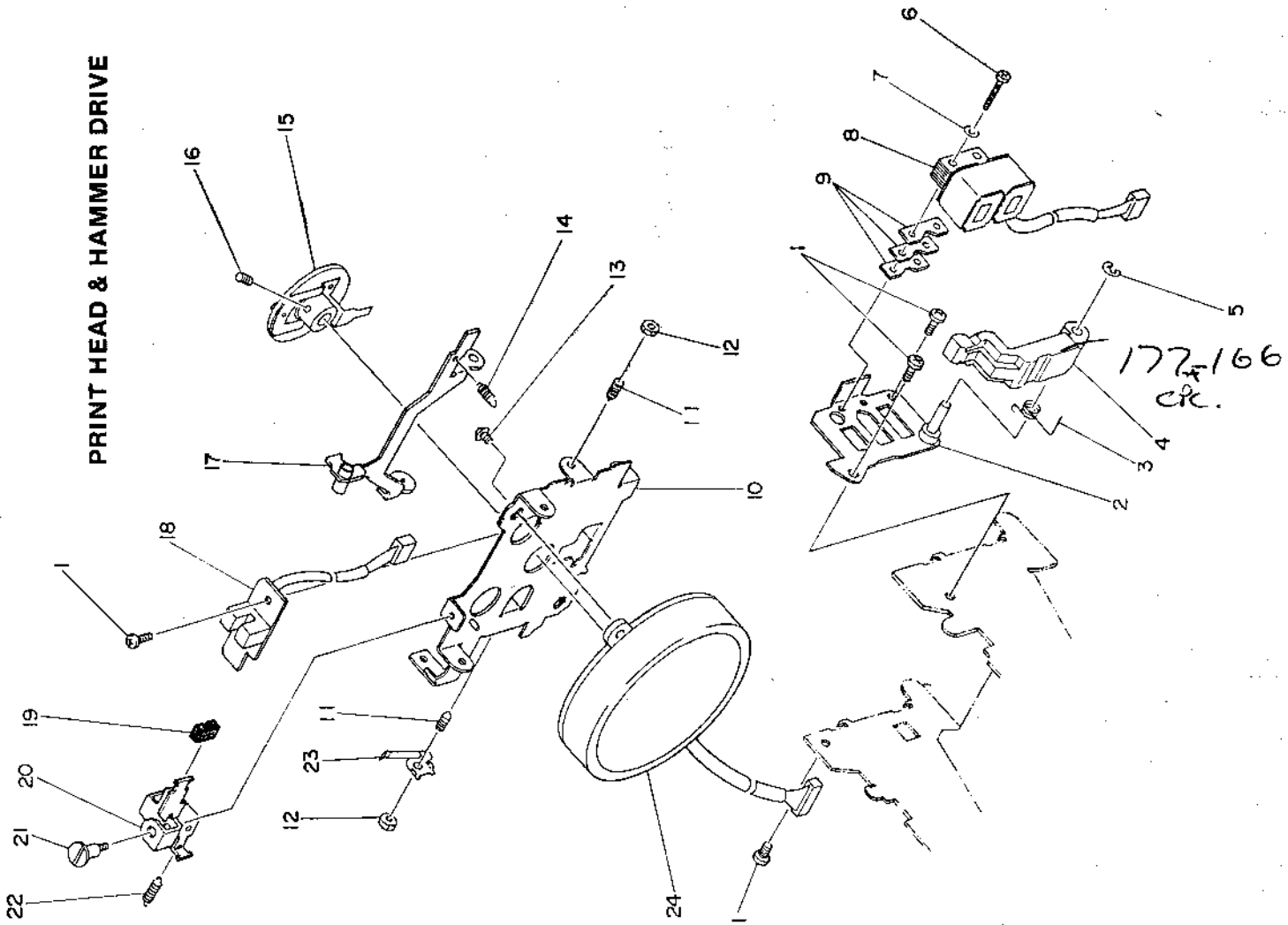

172-166  
circ.

CARRIER FRAME

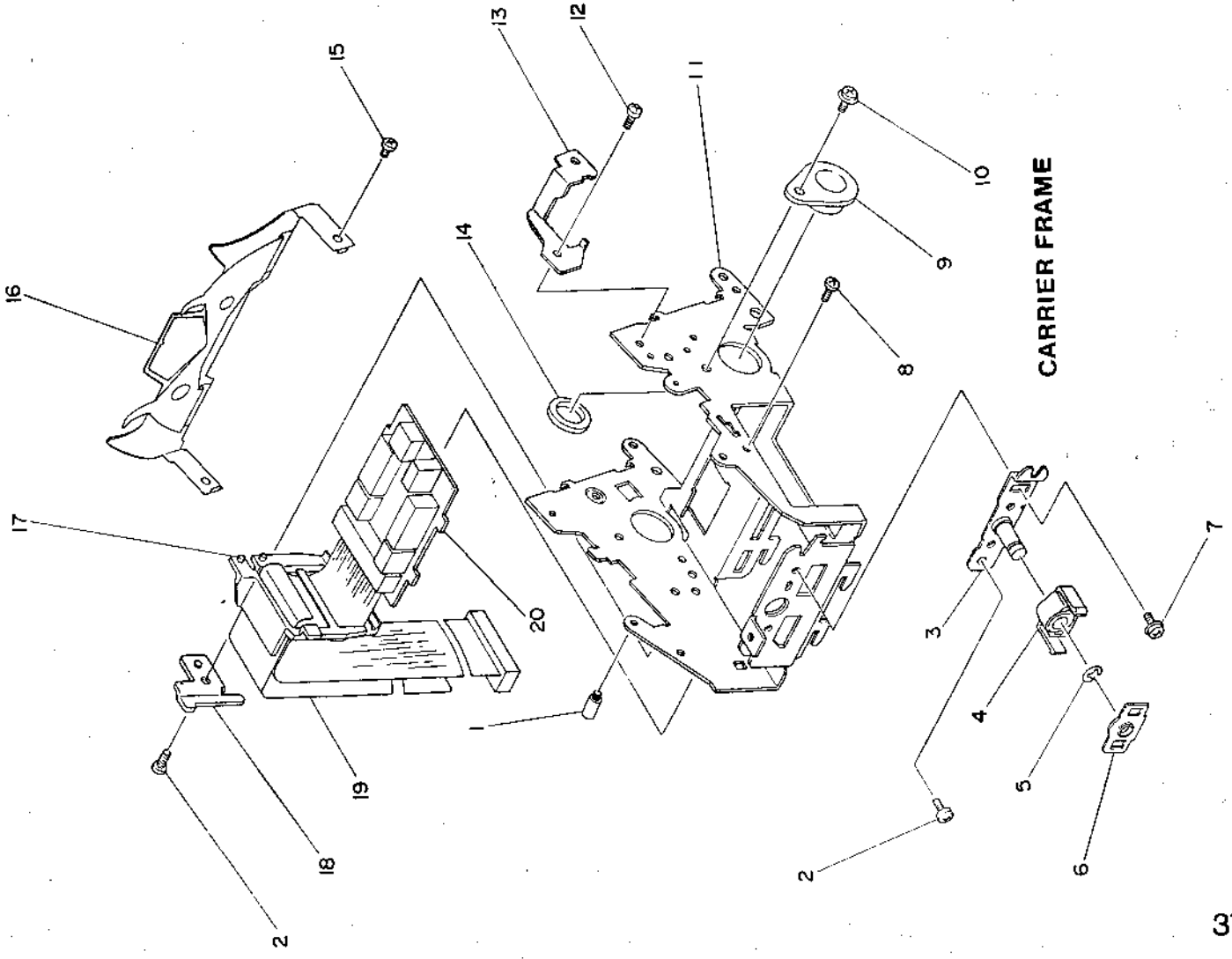

WHEEL SET RELEASE

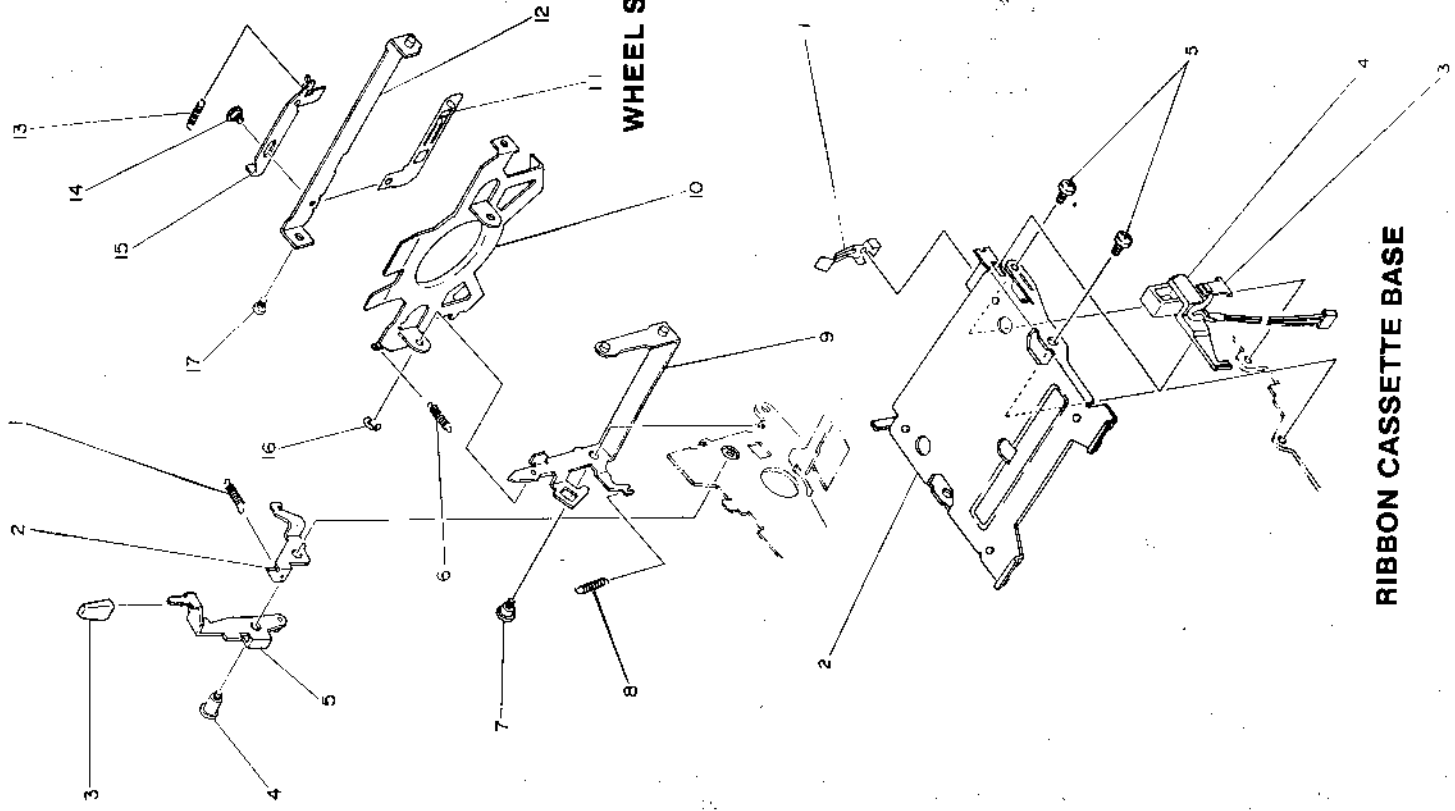

RIBBON CASSETTE BASE

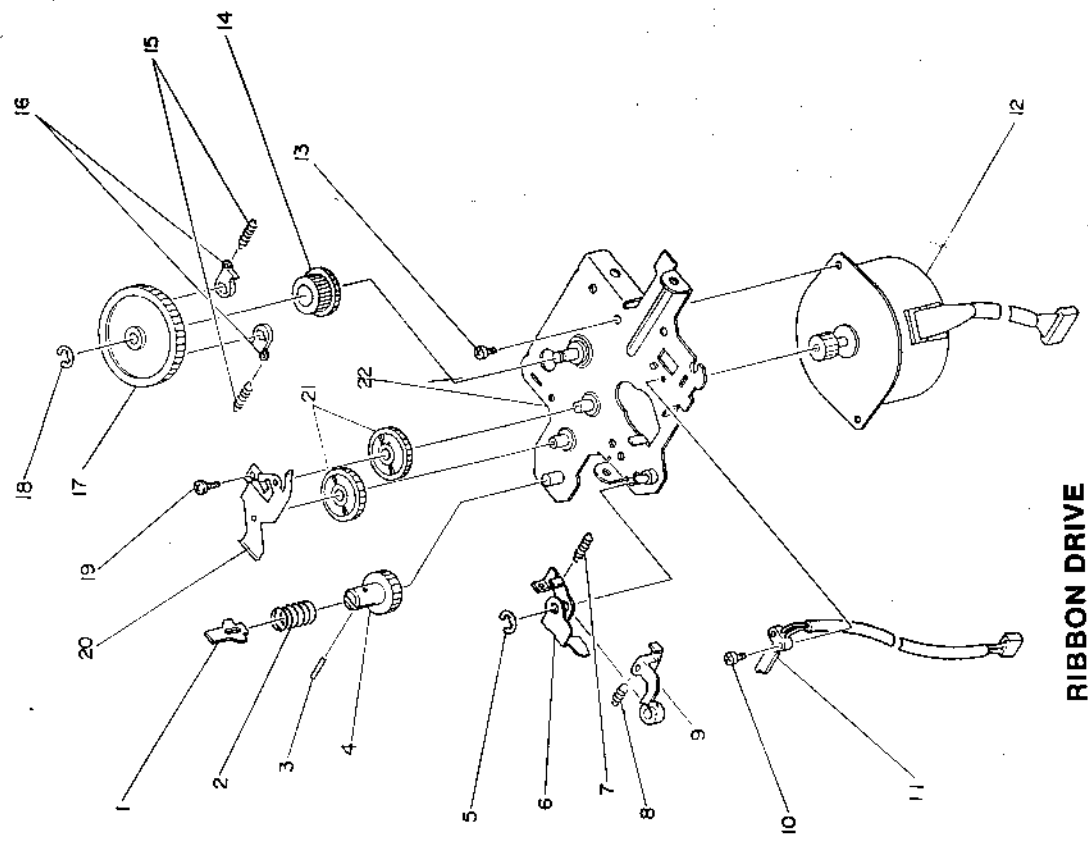

RIBBON DRIVE

# CPU CIRCUIT DIAGRAM

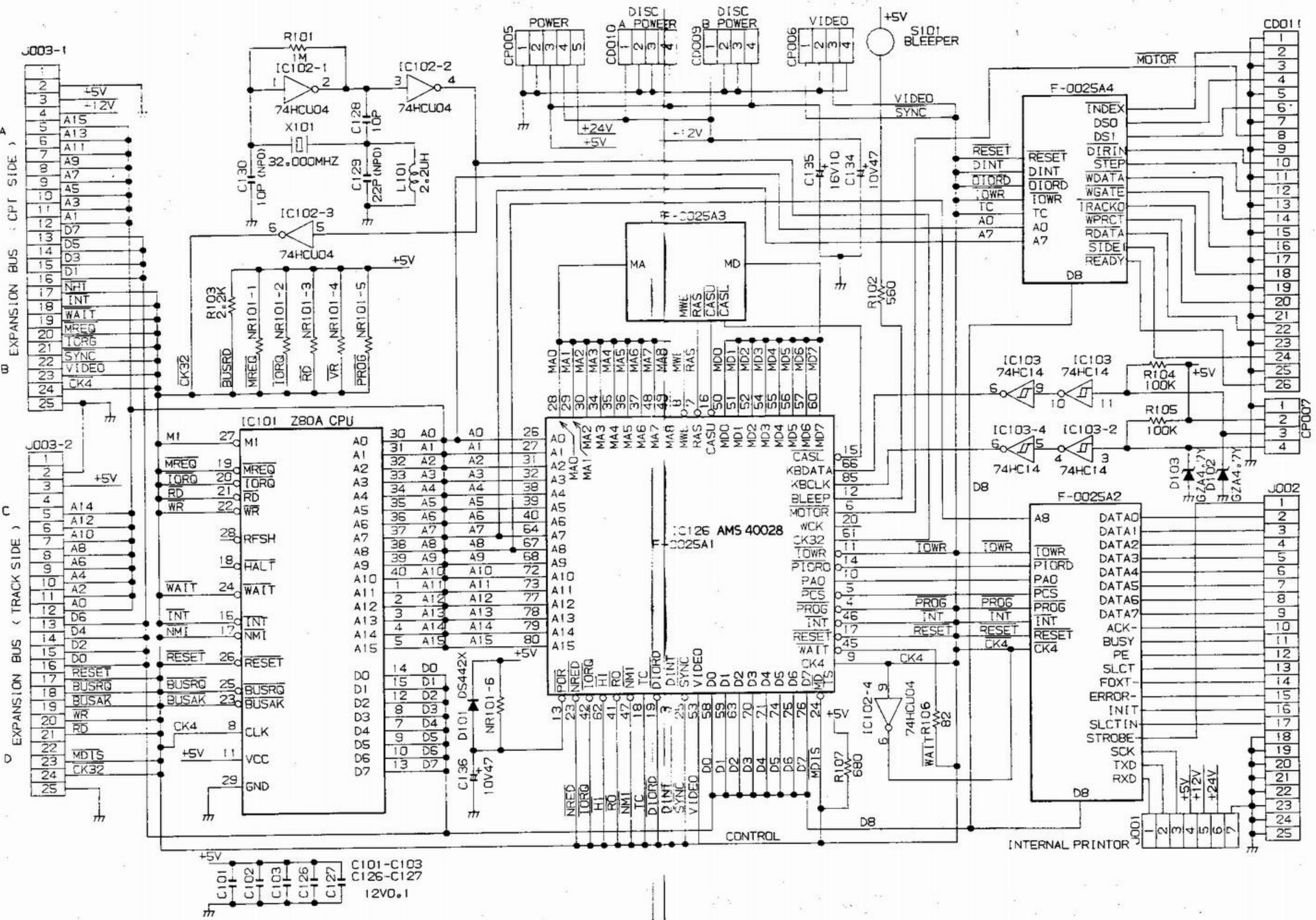

# PRINTER CONTROLLER CIRCUIT CHASSIS SCHEMATIC DIAGRAM

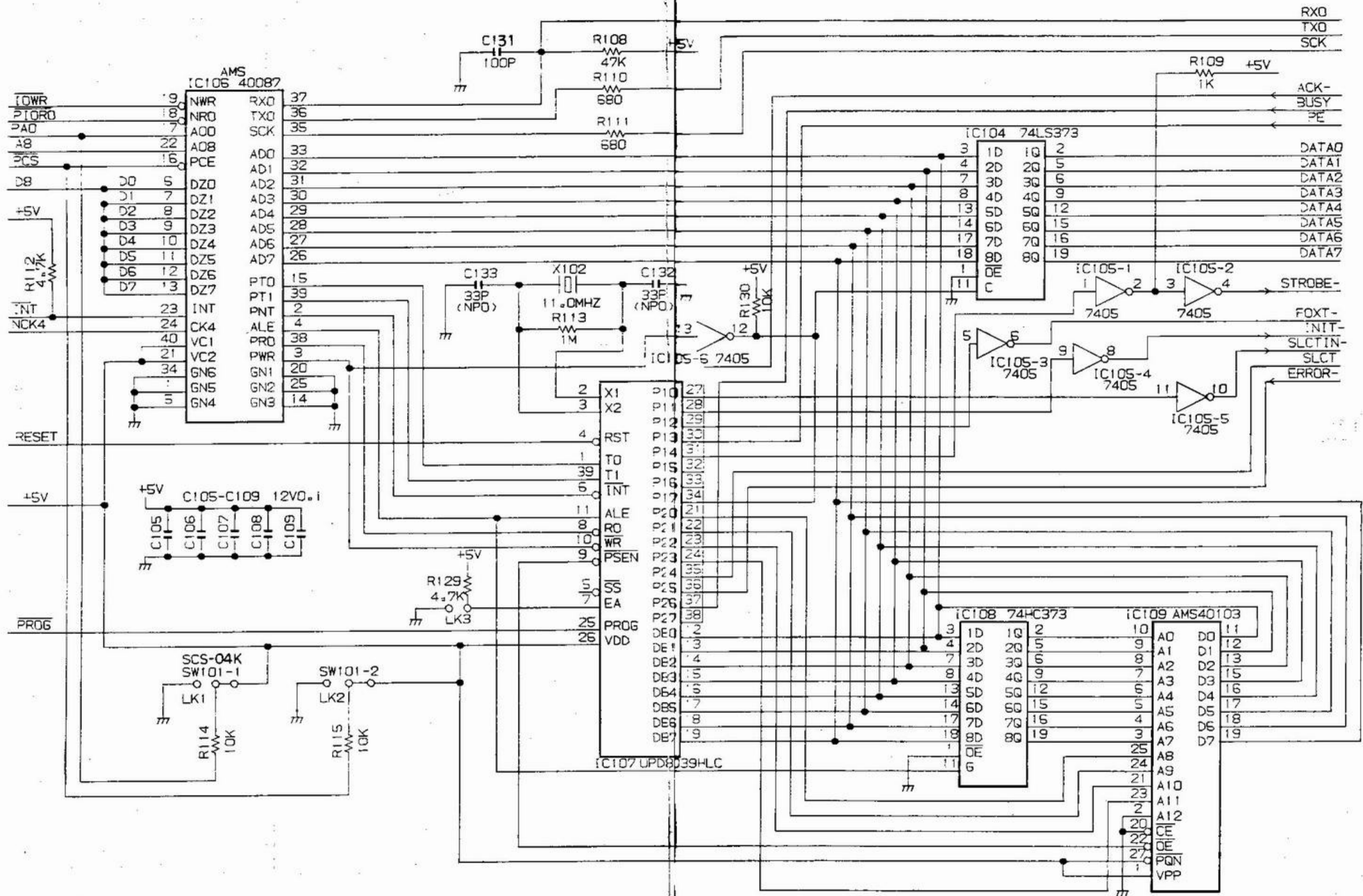

# FLOPPY DISC CONTROLLER CHASSIS SCHEMATIC DIAGRAM

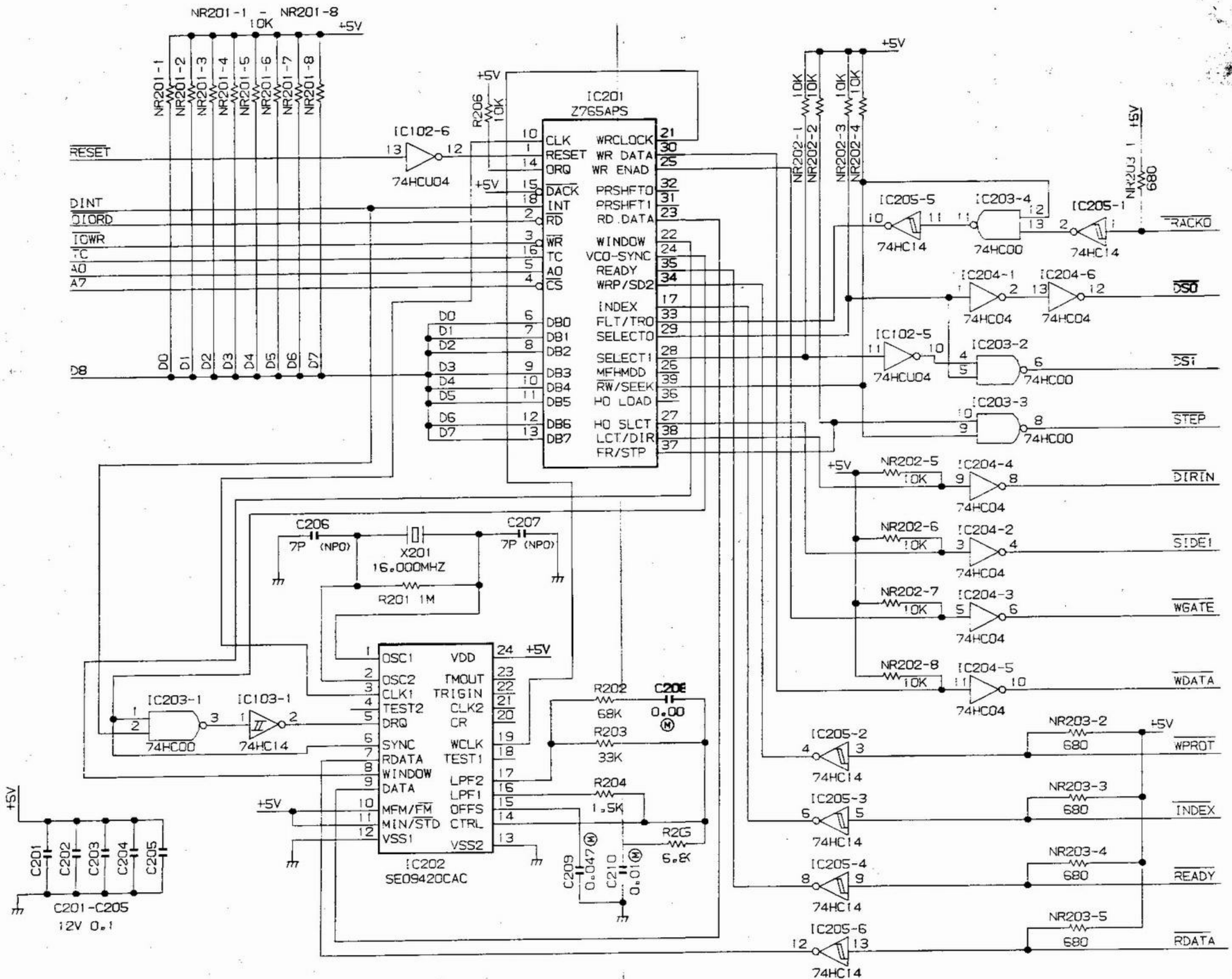



# PRINTER DRIVER CHASSIS SCHEMATIC DIRGRAM

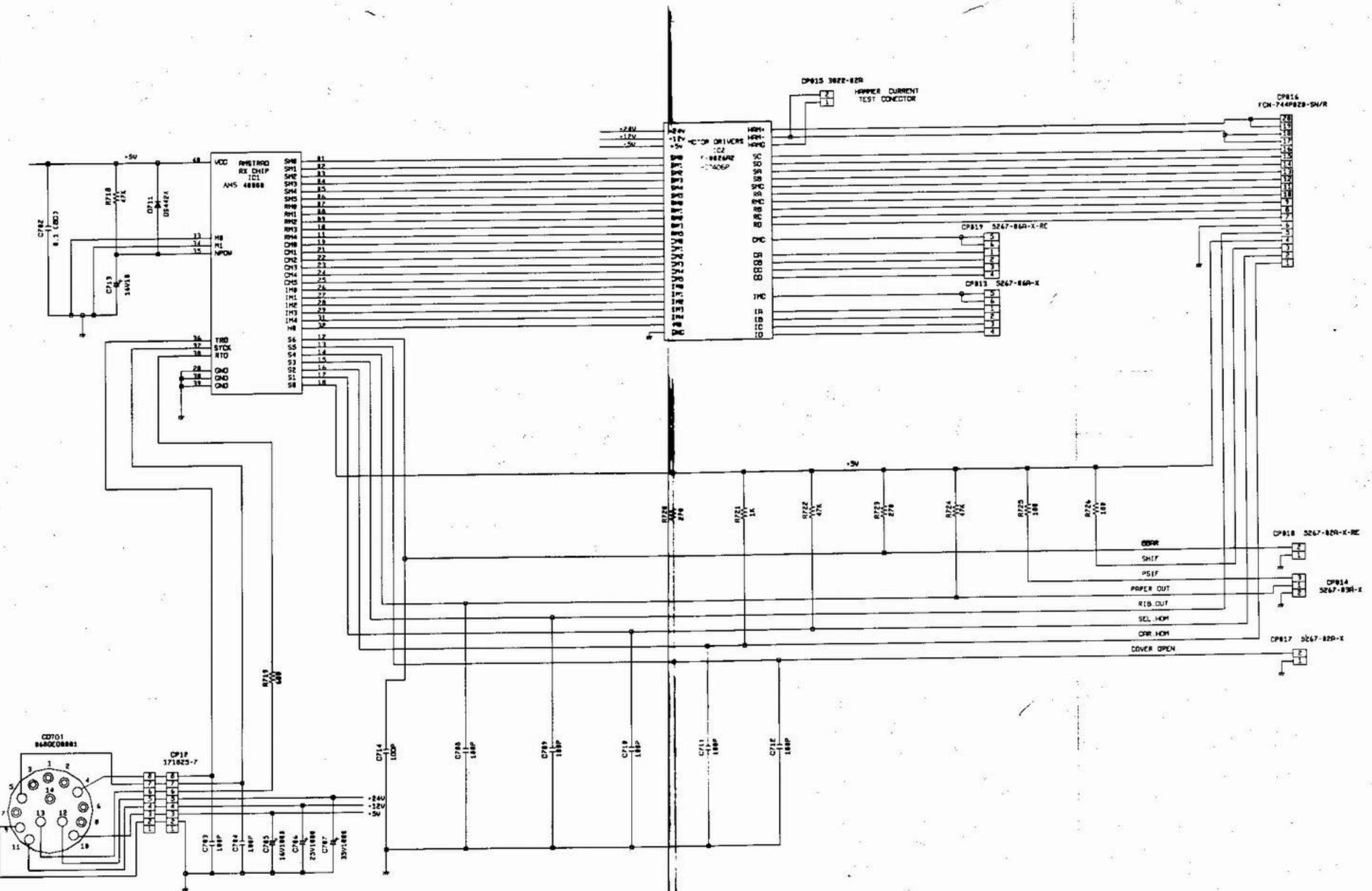

# PRINTER BUFFER CHASSIS SCHEMATIC DIAGRAM

