

SERVICE BULLETIN AMATEUR RADIO

| | |
|---|------------------|
| SUBJECT TA7201P SUBSTITUTION PARTS KIT | DATE 07/20/89 |
|---|------------------|

The Toshiba TA7201P audio amplifier (Q3) used in the TS-820(S) and R-820 is no longer available. The part has been replaced with a kit (PART # W05-0257-00). This service bulletin will provide the correct installation procedures for replacing a defective TA7201P with the new kit.

1. Disconnect the power cord and antenna from the transceiver.
2. Remove the covers from the transceiver and disconnect the speaker wire.
3. Remove the AF AVR board from the bottom of the transceiver (4 screws and 3 connectors).
4. Remove the two nuts that secure the heat sink to the audio amplifier (Q3) and then remove the heat sink. FIGURE 1
5. Desolder and remove Q3, C21, C22, C26, C33, R40, R42, and R47 from the AF AVR board. C33 and R47 are mounted on the foil side of the board, but may not be installed on some models. FIGURE 1 & 2
6. Using the parts from the kit, install a 22uF capacitor in the C21 position, a 0.068uF capacitor (labeled 683K) in the C22 position, a 3.9 ohm resistor in the R40 position, and a 470 ohm resistor in the R42 position. FIGURE 1
7. Solder a 0.1uF capacitor (labeled 104K) in parallel with C30. Mount the part on the foil side of the AF AVR board. FIGURE 1
8. Remove the two nuts from the heat sink mounting screws. FIGURE 3
9. Replace the mounting screws with the ones in the kit. If the original screws have been soldered to the board, remove the excess solder and while the screws are still hot, turn the board upside down to allow the screws to fall onto the working surface. FIGURE 3
10. Secure the new mounting screws with the two nuts that were removed in step 8. FIGURE 3
11. Install the heat sink and secure it with the two hexagon bosses from the kit. FIGURE 3

12. Insert the wires from the new audio amplifier circuit board as shown in the diagram. Make sure the pins are firmly seated and then solder them into place. FIGURE 4
13. Apply a thin layer of silicon grease to the back of the audio chip.
14. Insert the circuit board into the heat sink and secure it with the two nuts that were removed in step 4. Avoid pinching the wires between the board and the bosses as well as the board and the heat sink.
15. Attach the heat sink spring from the kit over the chip. FIGURE 5
16. Assemble the transceiver by reversing steps 1 - 3.

Note: Due to the differences in characteristics between the TA7201P and the new audio chip, the noise level will be increased. The increase in noise will effect the position of the AF gain control. Should it be found that the audio is too low, the value of resistor R4 on the AF AVR board can be reduced from 220 ohms to 82 ohms. The resistor removed from the R40 position can be used in this situation.

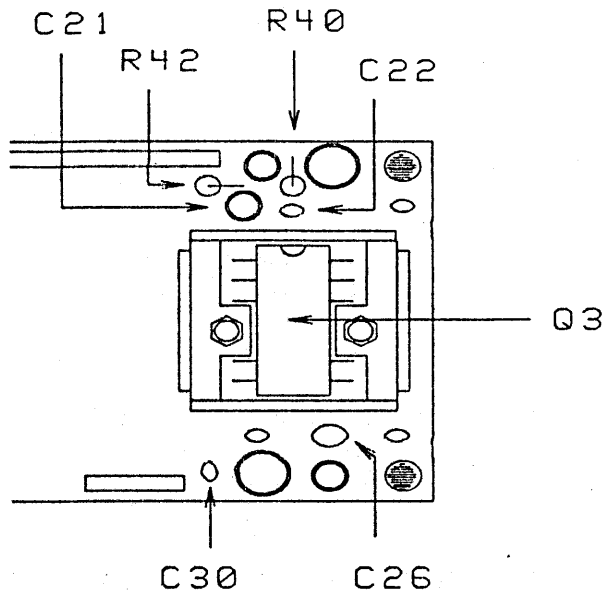

FIGURE 1

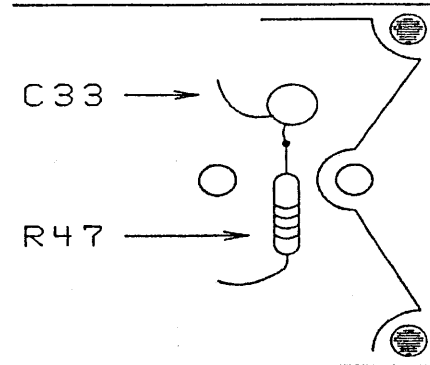

FIGURE 2

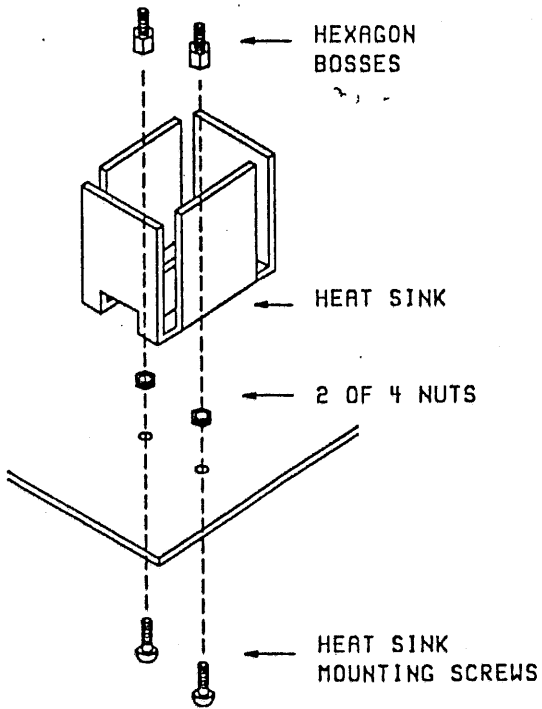

FIGURE 3

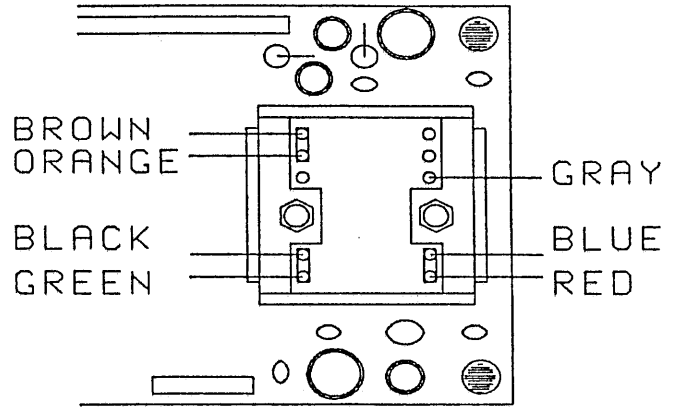

FIGURE 4

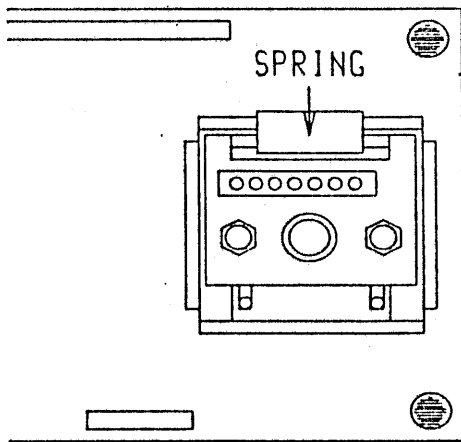

FIGURE 5

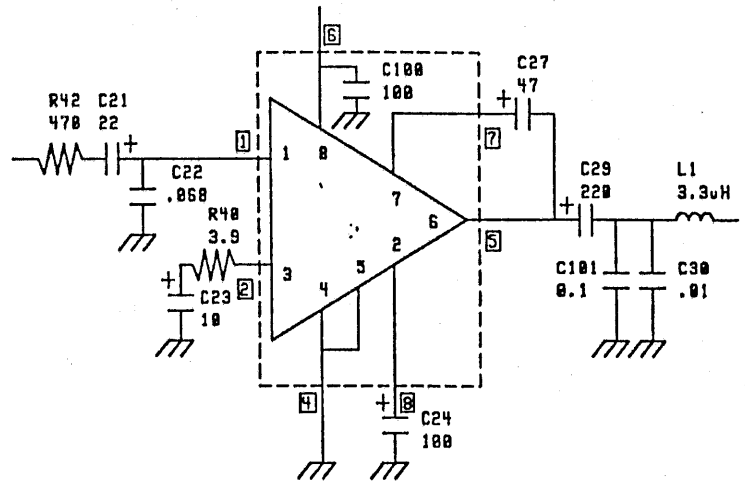

FIGURE 6

