

KENWOOD

SB-978

SERVICE BULLETIN AMATEUR RADIO

SUBJECT TH-75A INTERMITTENT MEMORY LOSS	DATE 08/08/90
--	------------------

Some TH-75A owners have reported that the transceiver intermittently loses its memory channel information after transmitting. Other users have reported symptoms such as key board lock up after transmitting. The following modification will re-configure the PTT input to the microprocessor to correct these conditions.

REQUIRED PARTS:

33K OHM CHIP RESISTOR	RK73GB1J333J
470pF CERAMIC CAPACITOR	CK45B1H471K
PTT TACTILE SWITCH	S40-1415-05

1. Disconnect the battery and antenna.
2. Remove the three case screws and two battery plate screws. **Figure 1**
3. Lift the front panel from the body of the transceiver and disconnect the two flex cables. To open the connectors push the tabs towards the flex cables and gently lift up. **Figure 2**
4. Remove the 4 screws from the Control board inside the front panel. **Figure 3**
5. Remove the 3 screws from the speaker mount. **Figure 3**
6. Carefully lift the Control board, PTT switch assembly, speaker, and mic element from the front panel. Do not break any wires.
7. Lay the Control board on a soft cloth to avoid scratching the LCD.
8. Locate chip capacitor C2 on the Control board. **Figure 4**
9. Replace C2 with a 33K ohm chip resistor.
10. Remove the protective coating from the foil between pin 58 of the microprocessor and chip resistor R8. Presolder the exposed foil. **Figure 5**
11. Size, cut, and bend the leads of the 470pF ceramic disc capacitor and then install the component between pin 59 of the microprocessor and the ground side of the 33K ohm chip resistor. **Figure 6**

PAGE 1 OF 5

12. Remove the screw from the PTT switch assembly and then remove the rubber PTT cover from the board. Be careful not to lose the black plastic plate that fits inside the rubber cover.
13. Remove the PTT switch from the board.
14. Cut the tabs off the bottom of the new PTT switch to allow the switch to lay flush on the board. Figure 7
15. Install the PTT switch.
16. Assemble the transceiver.

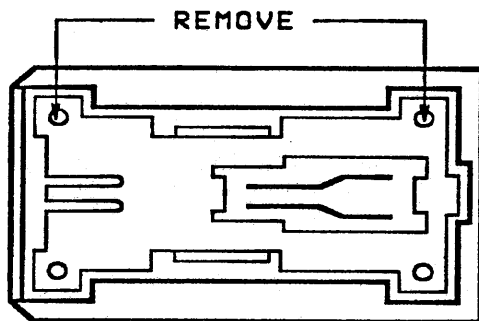
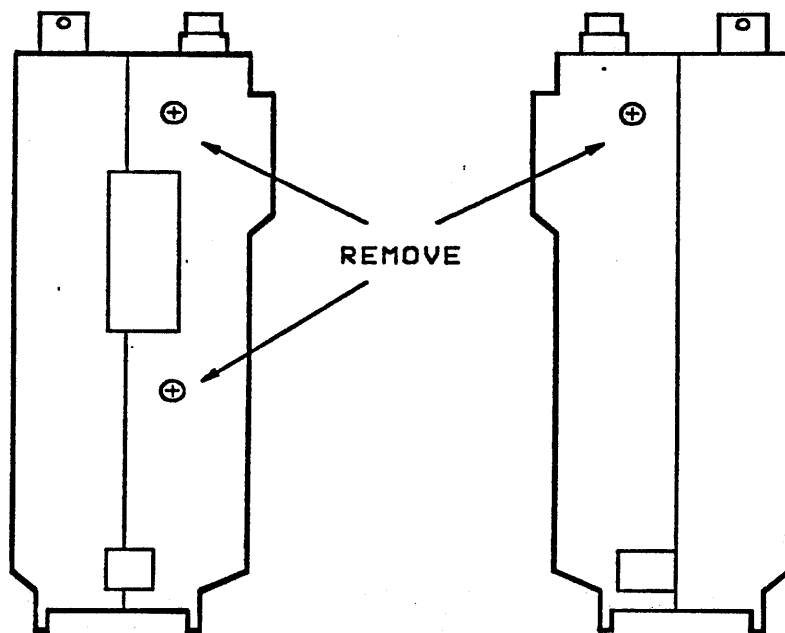

FIGURE 1

PAGE 2 OF 5

Time required to perform this modification is 1 hr. or less.
Copyright (C)080390EWP for Kenwood U.S.A. Corporation.

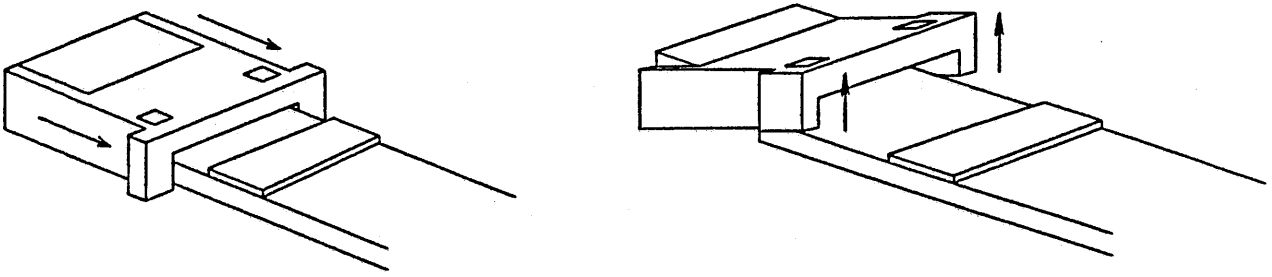

FIGURE 2

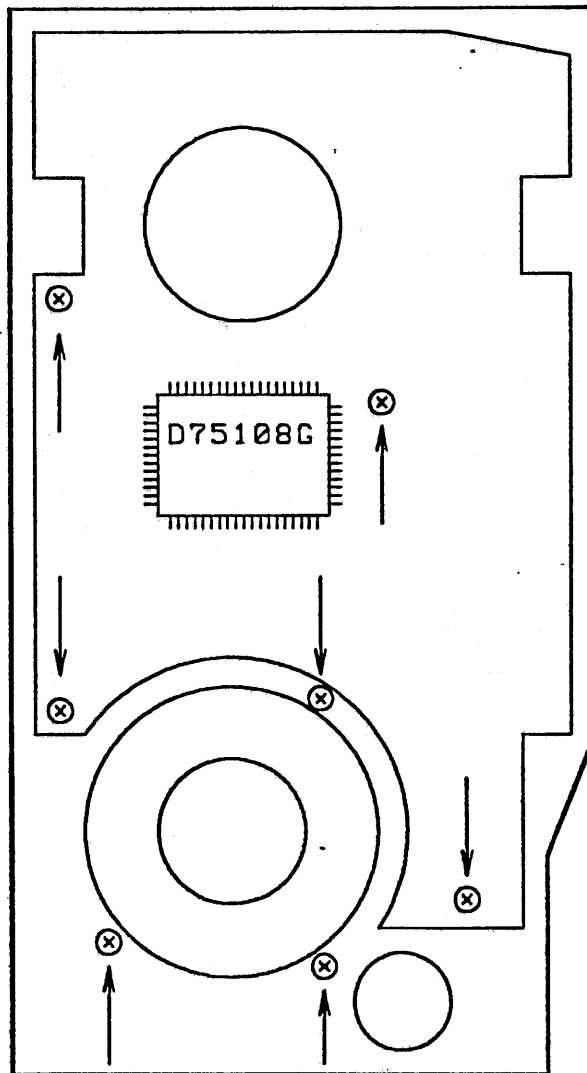

FIGURE 3

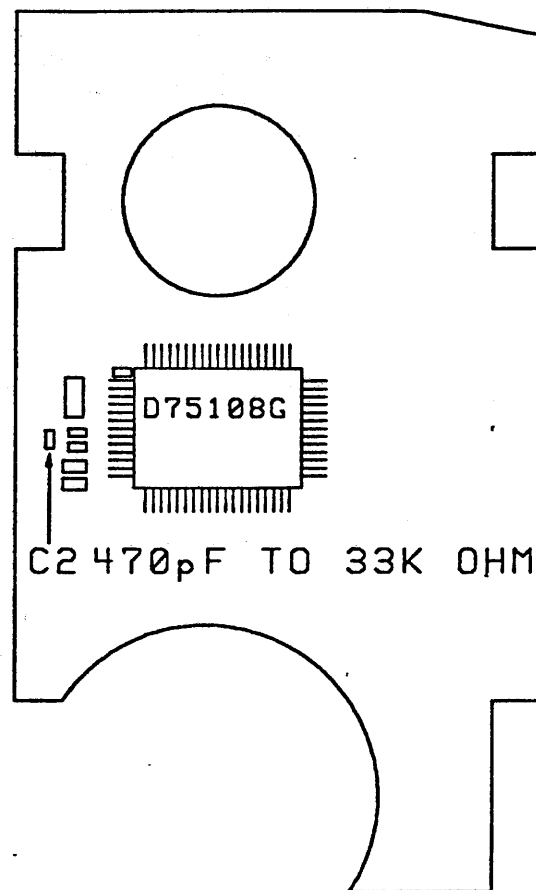

FIGURE 4

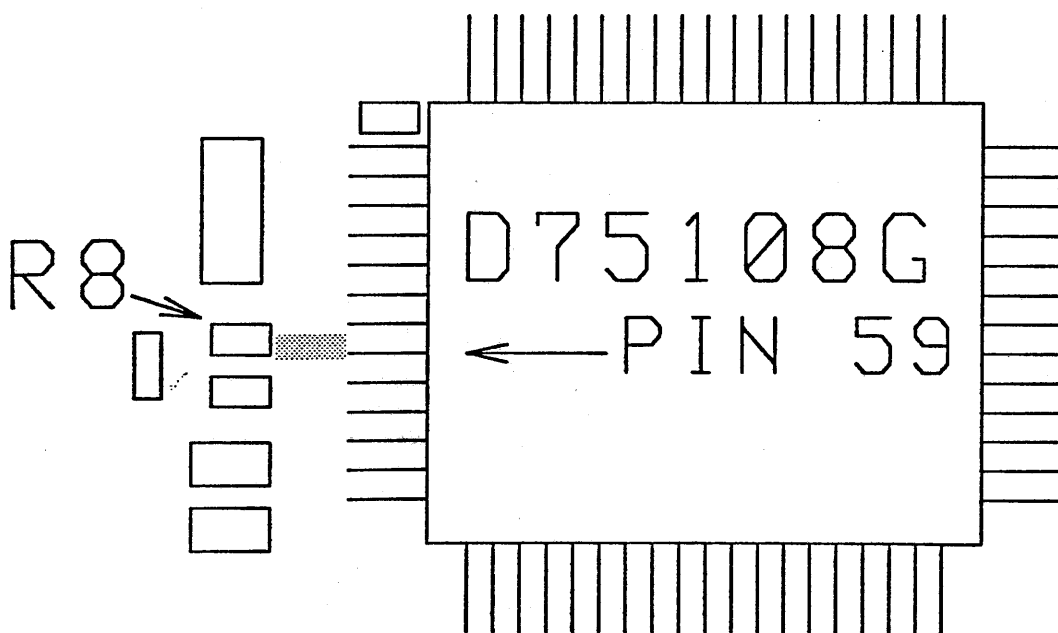

FIGURE 5

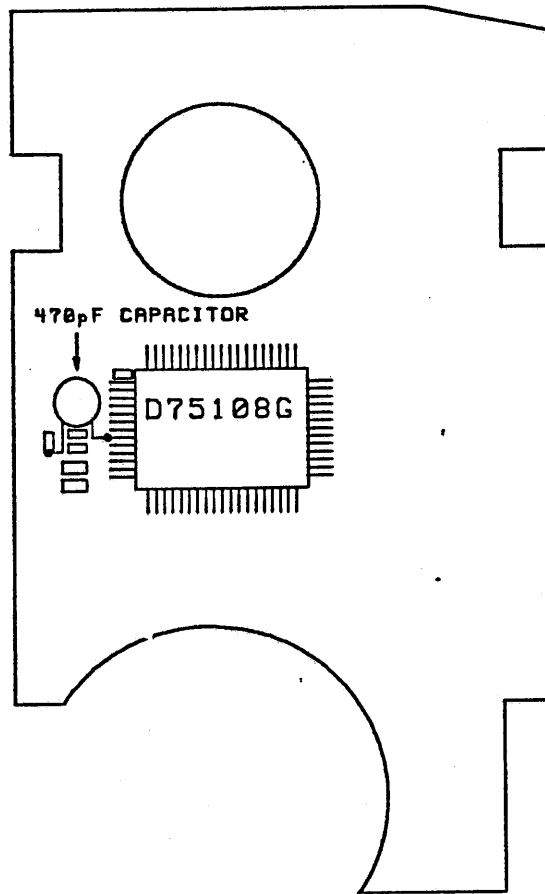

FIGURE 6

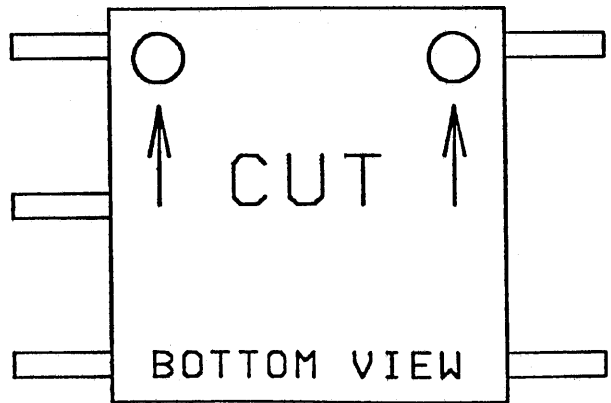
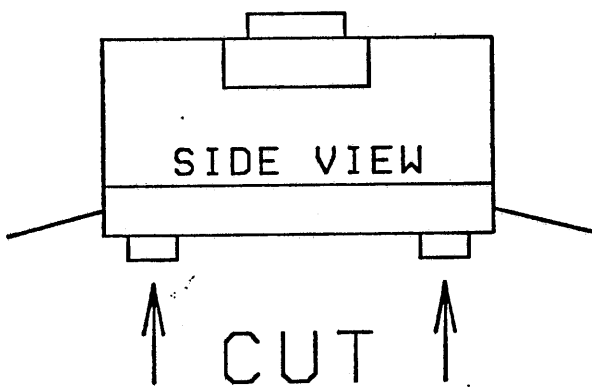

FIGURE 7

