

KENWOOD

SB-983

SERVICE BULLETIN AMATEUR RADIO

SUBJECT MC-48B MIC ELEMENT CHANGE	DATE 02/06/91
--------------------------------------	------------------

The original microphone element has been replaced. The new element has two connections and is much smaller than the original three connection element. When installing the new element, connect the wires as shown below. A 33K ohm, 1/4W resistor must be placed in series with the yellow wire. The rubber spacer is placed in front of the element when the microphone is assembled. The metal spacer can be discarded.

MIC ELEMENT PART # T97-1024-08

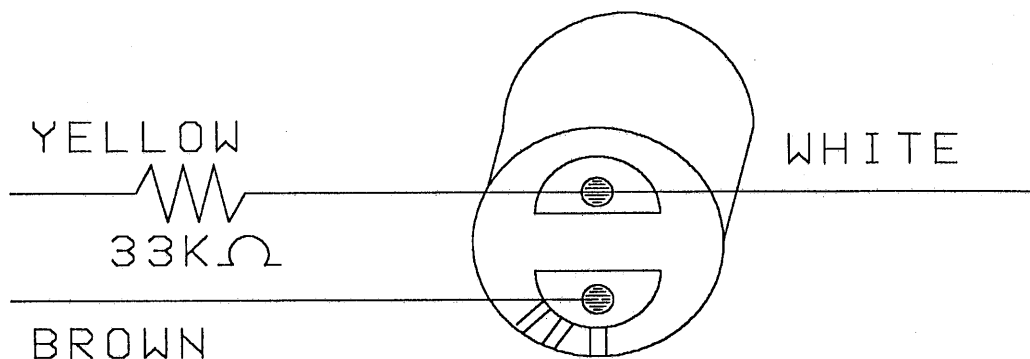
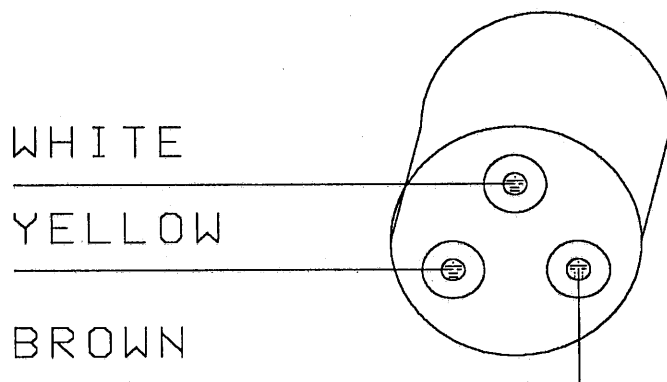

Copyright (C) 02/06/91 EWP for Kenwood U.S.A. Corporation.