

TL-922A 10M HINTS

DISCONNECT THE POWER CABLE BEFORE PROCEEDING

OPENING THE BANDSWITCH FOR 10M:

1. Remove the right-hand side panel, secured with (4) 5mm allen screws.
2. Remove the bottom cover, secured with (4) #2 Phillips screws (remove the feet as required).
3. Remove the bandswitch knob and dial skirt, using a small flat blade screwdriver to loosen the setscrews. Remove the small Phillips head screw just next to the switch. The bandswitch will now select 10M. **Proceed to REWIRING THE 10M AND 15M COILS and disregard the next 7 steps. If there is no Phillips head screw visible, perform the following 7 steps.**
1. Remove the four remaining knobs from the front panel.
2. Remove the front panel, secured by (2) screws on the top and (2) screws on the bottom.
3. Remove the bandswitch mounting nut and washer with a 12mm wrench.
4. Remove three Phillips screws securing the bandswitch mounting plate, but do not remove the plate.
5. Desolder two groups of capacitors from the back of the mounting plate and then set the plate aside.
6. Remove the small #1 Phillips head screw from the front of the bandswitch. The bandswitch will now select 10M.
7. Reinstall the mounting plate and mounting hardware.

REWIRING THE 10M AND 15M COILS (FIGURES 1 AND 2):

1. Remove the (3) capacitors from L14 and remove the (2) capacitors from L13 (FIG.1). Discard the capacitors.
2. Remove and discard the jumper wire that connects L13 and L14 (FIG.1).
3. Disconnect the remaining wire from the left side of L14 (leave the other end of the wire connected to the bandswitch). Solder this wire to the right side of L13 (REFER TO FIG.1&2 FOR LEFT/RIGHT ORIENTATION).
4. Add a wire between each side of L14 to the bandswitch (FIG.2). We recommend the use of AWG #18-22 wire and the use of solid insulation tubes like the ones already present.
5. Add a 120pF 500V silver mica or disc ceramic capacitor from the right side of L14 to ground (FIG.2).
6. Add a 120pF 500V silver mica or disc ceramic capacitor from the right side of L13 to ground (FIG.2).
7. If you had to disconnect the capacitors from the bandswitch mounting plate, connect them to the plate at this time.

CONNECTING THE CERAMIC BANDSWITCH CONTACTS (FIGURE 3):

1. Looking down into the TL-922A, locate the ceramic bandswitch. The load control should be turned fully counter clockwise to expose the switch.
2. Install a jumper from the front deck of the bandswitch to the rear deck as shown in figure 3. We recommend the use of AWG #10-14 wire. **Do not pull or bend the tabs on the ceramic wafers as this will cause the wafers to crack.**
3. This completes the modification. Replace the front panel and knobs (if removed), side panel, and bottom cover.
4. Cable-up and check the SWR between the exciter and linear, which should be 1.5:1 (nominal) or better. If the SWR is appreciably higher, adjust L13 (15M) or L14 (10M) as necessary for minimum reflected power to the exciter, coincidental with maximum linear output power.

SAFETY FIRST

REMEMBER, HIGH RF AND HIGH VOLTAGE ARE PRESENT. PLEASE BE CAREFUL!

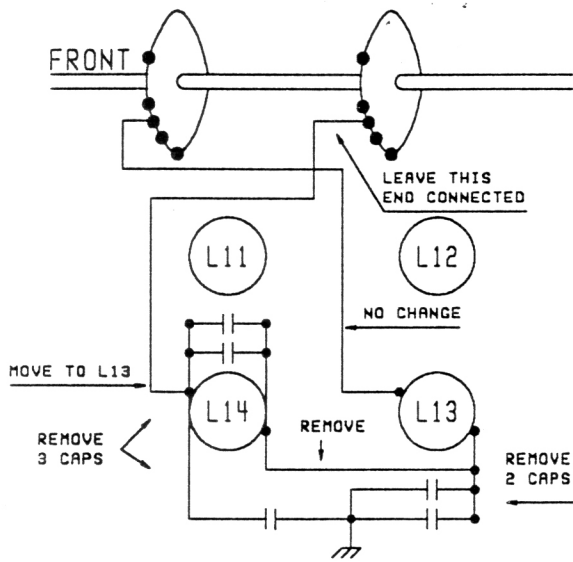

FIGURE 1

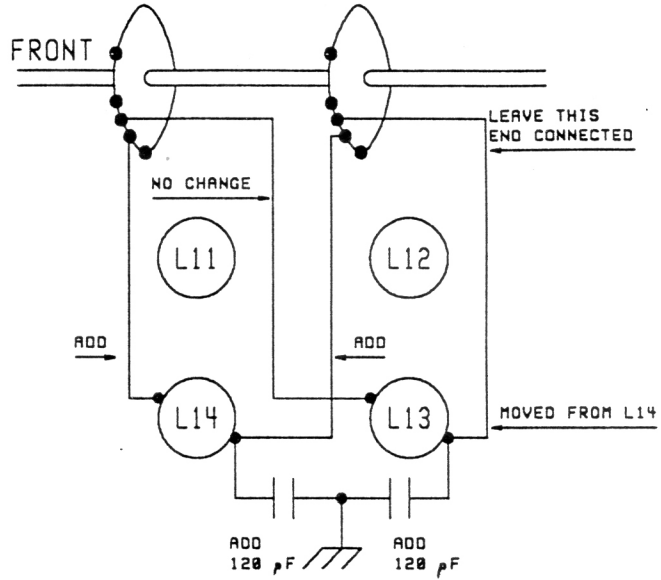

FIGURE 2

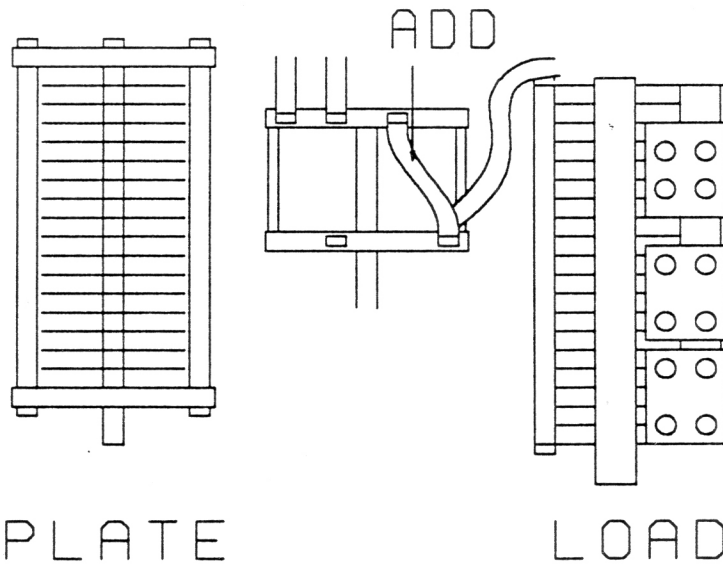

FIGURE 3

REQUIRED PARTS: TWO 120 pF, 500V CAPACITORS. KENWOOD PART # CM93D2H121J. AVAILABLE FROM KENWOOD'S PARTS DEPARTMENT.
 THE SERVICE MANUAL, AVAILABLE FROM KENWOOD'S PARTS DEPARTMENT, WOULD BE HELPFUL.