

# RM7000A™

## Microprocessor with On-Chip Secondary Cache

### Data Sheet

**Preliminary**

**Issue No. 5: August 2002**

## Legal Information

### Copyright

Copyright 2002 PMC-Sierra, Inc. All rights reserved.

The information in this document is proprietary and confidential to PMC-Sierra, Inc., and for its customers' internal use. In any event, no part of this document may be reproduced or redistributed in any form without the express written consent of PMC-Sierra, Inc.

PMC-2002227 (R5)

### Disclaimer

None of the information contained in this document constitutes an express or implied warranty by PMC-Sierra, Inc. as to the sufficiency, fitness or suitability for a particular purpose of any such information or the fitness, or suitability for a particular purpose, merchantability, performance, compatibility with other parts or systems, of any of the products of PMC-Sierra, Inc., or any portion thereof, referred to in this document. PMC-Sierra, Inc. expressly disclaims all representations and warranties of any kind regarding the contents or use of the information, including, but not limited to, express and implied warranties of accuracy, completeness, merchantability, fitness for a particular use, or non-infringement.

In no event will PMC-Sierra, Inc. be liable for any direct, indirect, special, incidental or consequential damages, including, but not limited to, lost profits, lost business or lost data resulting from any use of or reliance upon the information, whether or not PMC-Sierra, Inc. has been advised of the possibility of such damage.

### Trademarks

PMC-Sierra and RM7000C and Fast Packet Cache are trademarks of PMC-Sierra, Inc. Other product and company names mentioned herein may be the trademarks of their respective owners.

### Patents

#### Granted

The technology discussed is protected by one or more of the following patent grants.

U.S. Patent Numbers 5 953 748, 5 606 683, 5 760 620

Relevant patent applications and other patents may also exist.

## Contacting PMC-Sierra

PMC-Sierra  
8555 Baxter Place  
Burnaby, BC  
Canada V5A 4V7

Tel: +1 (604) 415-6000  
Fax: +1 (604) 415-6200

Document Information: [document@pmc-sierra.com](mailto:document@pmc-sierra.com)  
Corporate Information: [info@pmc-sierra.com](mailto:info@pmc-sierra.com)  
Technical Support: [apps@pmc-sierra.com](mailto:apps@pmc-sierra.com)  
Web Site: <http://www.pmc-sierra.com>

## Revision History

Issue No.	Issue Date	Details of Change
5	August 2002	Updated pin AA2 from V <sub>CCInt</sub> to V <sub>SSInt</sub> .
4	March 2002	Updated Dhystone value from 600 to 720, page 9. Modified Mode Bit 11 descriptions on page 35 and Table 16, page 38. Modified SysClk values for 300 and 350 MHz CPU frequencies, Section 10.2, Clock Parameters, page 47. Modified (Figure 5) CP0 Register Diagram, (Figure 8) Typical Embedded Block Diagram, (Figure 6) Kernal Mode Virtual Addressing. Changed references from external controller to external agent, F-type to F pipe, SysAD I/F to System I/F. Various formatting and editing changes.
3	September 2001	Updated power consumption values.
2	May 2001	Changed pin AC13 SysCmd[2] from active low to high. Added industrial values to Recommended Operating Instructions Added industrial and commercial values to Absolute Maximum Ratings Changed Timer Interrupt Enable/Disable information in Boot Time Mode Stream table Added paragraph to Interrupt Handling section Clarification added to System Interface Parameters Additional information added to Clock Parameter table
1	January 2001	Applied PMC-Sierra template to existing MPD (QED) FrameMaker document. In the Pinout Table, changed all references from IP to INT Section 1, Features, changed High-performance system interface, 133 MHz maximum frequency, multiplexed address/data to 125 MHz. Changed QED references to PMC-Sierra or MIPS. Updated Section 7, Recommended Operating Conditions and Section 9 Power Consumption. Added System Interface Parameter values, Section 10.3, for 350 MHz and 400 MHz CPU speeds.

## Document Conventions

The following conventions are used in this data sheet:

- All signal, pin, and bus names described in the text, such as **ExtRqst\***, are in boldface typeface.
- All register bit and field names described in the text, such as ***Interrupt Mask***, are in an italic-bold typeface.
- All instruction names, such as MFHI, are in san serif typeface.

## Table of Contents

Legal Information.....	2
Copyright.....	2
Disclaimer .....	2
Trademarks .....	2
Patents .....	2
Contacting PMC-Sierra.....	3
Revision History.....	4
Document Conventions .....	5
Table of Contents.....	6
List of Figures .....	9
List of Tables.....	10
1 Features .....	11
2 Block Diagram.....	13
3 Description .....	14
4 Hardware Overview .....	15
4.1 CPU Registers.....	15
4.2 Superscalar Dispatch .....	15
4.3 Pipeline.....	16
4.4 Integer Unit.....	17
4.5 ALU .....	18
4.6 Integer Multiply/Divide.....	18
4.7 Floating-Point Coprocessor.....	19
4.8 Floating-Point Unit.....	19
4.9 Floating-Point General Register File .....	20
4.10 System Control Coprocessor (CP0).....	21
4.11 System Control Coprocessor Registers.....	21
4.12 Virtual to Physical Address Mapping.....	22
4.13 Joint TLB .....	23
4.14 Instruction TLB .....	25
4.15 Data TLB .....	25
4.16 Cache Memory.....	25
4.17 Instruction Cache .....	25
4.18 Data Cache .....	26

4.19	Secondary Cache.....	28
4.20	Secondary Caching Protocols.....	29
4.21	Tertiary Cache.....	29
4.22	Cache Locking.....	31
4.23	Cache Management.....	31
4.24	Primary Write Buffer.....	32
4.25	System Interface.....	32
4.26	System Address/Data Bus.....	33
4.27	System Command Bus.....	33
4.28	Handshake Signals.....	34
4.29	System Interface Operation.....	34
4.30	Data Prefetch.....	37
4.31	Enhanced Write Modes.....	37
4.32	External Requests.....	37
4.33	Test/Breakpoint Registers.....	38
4.34	Performance Counters.....	38
4.35	Interrupt Handling.....	40
4.36	Standby Mode.....	42
4.37	JTAG Interface.....	42
4.38	Boot-Time Options.....	43
4.39	Boot-Time Modes.....	43
5	Pin Descriptions.....	46
6	Absolute Maximum Ratings <sup>1</sup> .....	50
7	Recommended Operating Conditions.....	51
8	DC Electrical Characteristics.....	52
9	Power Consumption.....	53
10	AC Electrical Characteristics.....	54
10.1	Capacitive Load Deration.....	54
10.2	Clock Parameters.....	54
10.3	System Interface Parameters.....	55
10.4	Boot-Time Interface Parameters.....	55
11	Timing Diagrams.....	56
11.1	Clock Timing.....	56
11.2	System Interface Timing.....	56
12	Packaging Information.....	57

---

13	RM7000A Pinout .....	58
14	Ordering Information .....	60
	Notes .....	61

Downloaded by ahmed metwaly of siliconexpert on Monday, 06 January, 2003 03:28:22 AM

## List of Figures

Figure 1	Block Diagram.....	13
Figure 2	CPU Registers.....	15
Figure 3	Instruction Issue Paradigm.....	16
Figure 4	Pipeline.....	17
Figure 5	CP0 Registers.....	22
Figure 6	Kernel Mode Virtual Addressing (32-bit).....	23
Figure 7	Tertiary Cache Hit and Miss.....	30
Figure 8	Typical Embedded System Block Diagram.....	33
Figure 9	Processor Block Read.....	35
Figure 10	Processor Block Write.....	36
Figure 11	Multiple Outstanding Reads.....	36
Figure 12	Clock Timing.....	56
Figure 13	Input Timing.....	56
Figure 14	Output Timing.....	56
Figure 15	304-TBGA Drawing.....	57

## List of Tables

Table 1	Instruction Issue Rules .....	16
Table 2	Dual Issue Instruction Classes .....	16
Table 3	ALU Operations .....	18
Table 4	Integer Multiply/Divide Operations .....	18
Table 5	Floating Point Latencies and Repeat Rates .....	20
Table 6	Cache Attributes .....	30
Table 7	Cache Locking Control .....	31
Table 8	Penalty Cycles .....	32
Table 9	Watch Control Register .....	38
Table 10	Performance Counter Control .....	39
Table 11	Cause Register .....	41
Table 12	Interrupt Control Register .....	41
Table 13	IPLLO Register .....	41
Table 14	IPLHI Register .....	41
Table 15	Interrupt Vector Spacing .....	42
Table 16	Boot Time Mode Stream .....	44
Table 17	System Interface .....	46
Table 18	Clock/Control Interface .....	47
Table 19	Tertiary Cache Interface .....	47
Table 20	Interrupt Interface .....	48
Table 21	JTAG Interface .....	48
Table 22	Initialization Interface .....	49
Table 23	( $V_{CCIO} = 3.15\text{ V} - 3.45\text{ V}$ ) .....	52
Table 24	( $V_{CCIO} = 2.3\text{ V} - 2.7\text{ V}$ ) .....	52

## 1 Features

- Dual issue symmetric superscalar microprocessor with instruction prefetch optimized for system level price/performance
  - 300, 350, 400 MHz operating frequency
  - >720 Dhrystone 2.1 MIPS @ 400 MHz
- High-performance system interface
  - 1000 MB per second peak throughput
  - 125 MHz max. freq., multiplexed address/data
  - Supports two outstanding reads with out-of-order return
  - Processor clock multipliers 2, 2.5, 3, 3.5, 4, 4.5, 5, 6, 7, 8, 9
- Integrated primary and secondary caches
  - All are 4-way set associative with 32 byte line size
  - 16 KB instruction, 16 KB data, 256 KB on-chip secondary
  - Per line cache locking in primaries and secondary
  - Fast Packet Cache™ increases system efficiency in networking applications
- Integrated external cache controller (up to 8 MB)
- High-performance floating-point unit — 800 MFLOPS maximum
  - Single cycle repeat rate for common single-precision operations and some double-precision operations
  - Single cycle repeat rate for single-precision combined multiply-add operations
  - Two cycle repeat rate for double-precision multiply and double-precision combined multiply-add operations
- MIPS IV superset instruction set architecture
  - Data PREFETCH instruction allows the processor to overlap cache miss latency and instruction execution
  - Single-cycle floating-point multiply-add
- Integrated memory management unit
  - Fully associative joint TLB (shared by I and D translations)
  - 64/48 dual entries map 128/96 pages
  - Variable page size
- Embedded application enhancements
  - Specialized DSP integer Multiply-Accumulate instructions, (MAD/MADU) and three-operand multiply instruction (MUL)
  - I&D Test/Break-point (Watch) registers for emulation & debug
  - Performance counter for system and software tuning & debug
  - Fourteen fully prioritized vectored interrupts — 10 external, 2 internal, 2 software

- Fully static CMOS design with dynamic power down logic
- RM5271 pin compatible, 304 pin TBGA package, 31x31 mm

Downloaded by ahmed metwaly of siliconexpert on Monday, 06 January, 2003 03:28:22 AM

## 2 Block Diagram

Figure 1 Block Diagram

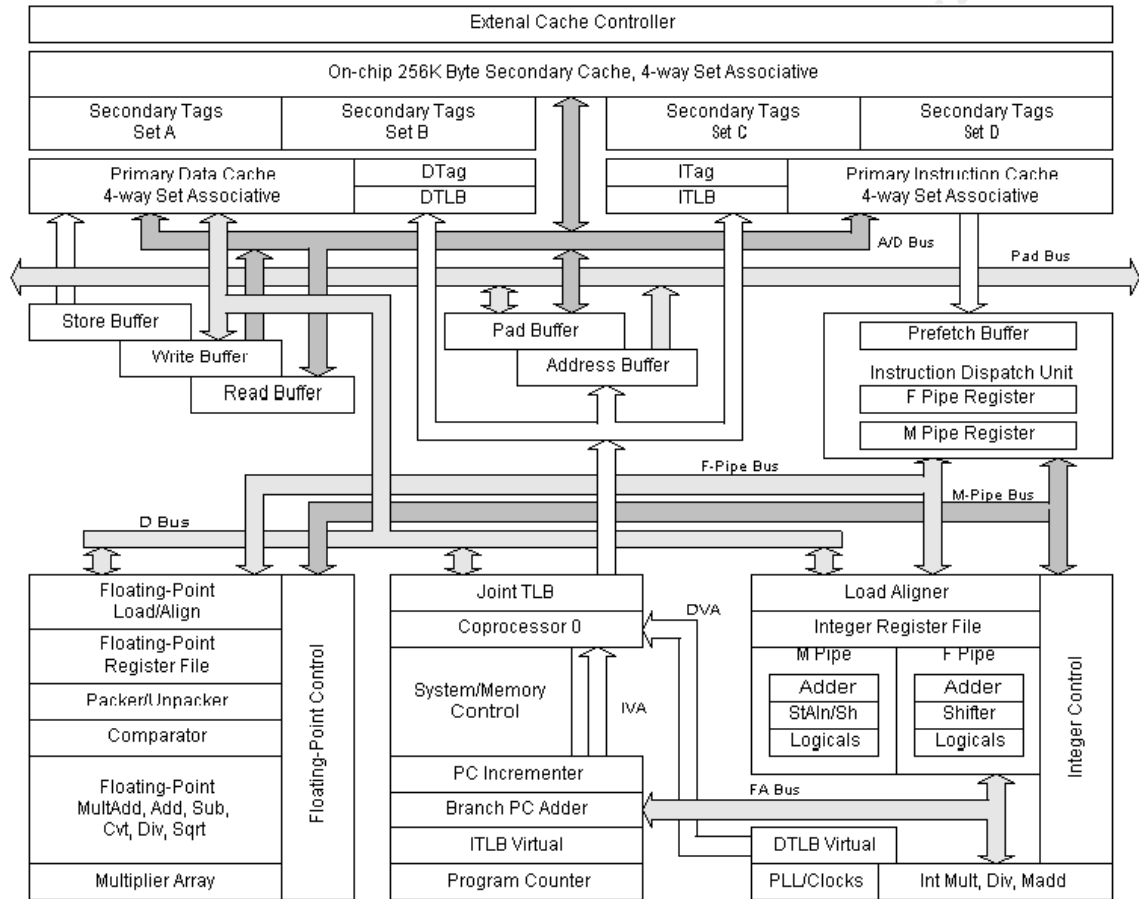

### 3 Description

PMC-Sierra's RM7000A™ Microprocessor is a highly integrated symmetric superscalar microprocessor capable of issuing two instructions each processor cycle. It has two high-performance 64-bit integer units as well as a high-throughput, fully pipelined 64-bit floating point unit.

The RM7000A integrates 16 KB 4-way set associative instruction and data caches along with an integrated 256 KB 4-way set associative secondary. The primary data and secondary caches are write-back and non-blocking. An optional external tertiary cache provides high-performance capability even in applications with very large data sets.

The memory management unit contains a 64/48-entry fully associative TLB and a 64-bit system interface supporting multiple outstanding reads with out-of-order return and hardware prioritized and vectored interrupts.

The RM7000A ideally suits high-end embedded control applications such as internetworking, high-performance image manipulation, high-speed printing, and 3-D visualization. The RM7000A is also applicable to the low-end workstation market where its balanced integer and floating-point performance and direct support for a large tertiary cache (up to 8 MB) provide outstanding price/performance.

## 4 Hardware Overview

The RM7000A offers a high-level of integration targeted at high-performance embedded applications. The key elements of the RM7000A are described throughout this section.

### 4.1 CPU Registers

The RM7000A CPU contains 32 general purpose registers (GPR), two special purpose registers for integer multiplication and division, and a program counter; there are no condition code bits. Figure 2 shows these processor registers. The RM7000A also contains two sets of CP0 registers. These CP0 register sets contain both 32 and 64-bit registers. Only 29 of the 32 registers specified in CP0, Set 0 are implemented, and only 5 of the 32 registers in CP0, Set 1 are implemented.

**Figure 2 CPU Registers**

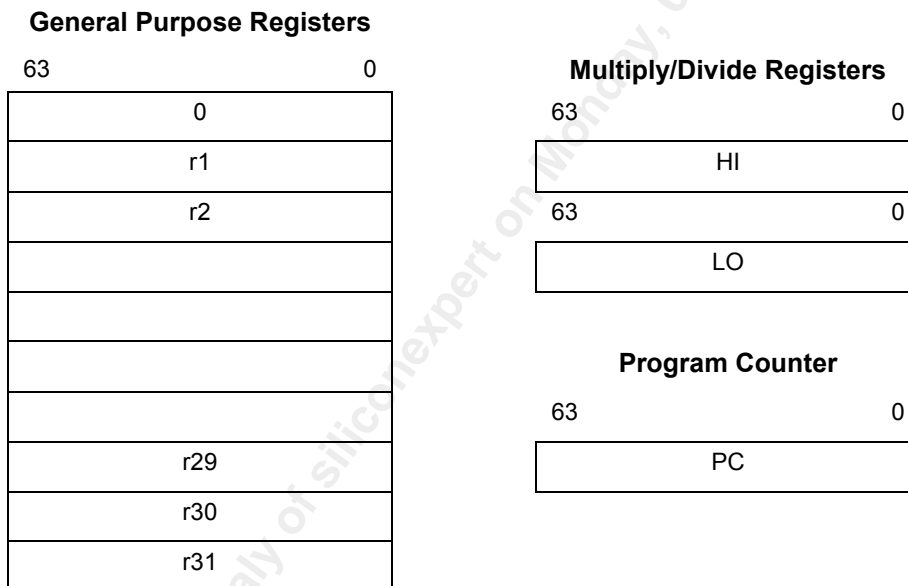

### 4.2 Superscalar Dispatch

The RM7000A incorporates a superscalar dispatch unit that allows it to issue up to two instructions per cycle. For purposes of instruction issue, the RM7000A defines four classes of instructions: integer, load/store, branches, and floating-point. There are two logical pipelines, the *function*, or F, pipeline and the *memory*, or M, pipeline. Note however that the M pipe can execute integer as well as memory type instructions.

**Table 1 Instruction Issue Rules**

F Pipe	M Pipe
one of:	one of:
integer, branch, floating-point, integer mul, div	integer, load/store

Figure 3 is a simplification of the pipeline section and illustrates the basics of the instruction issue mechanism.

**Figure 3 Instruction Issue Paradigm**

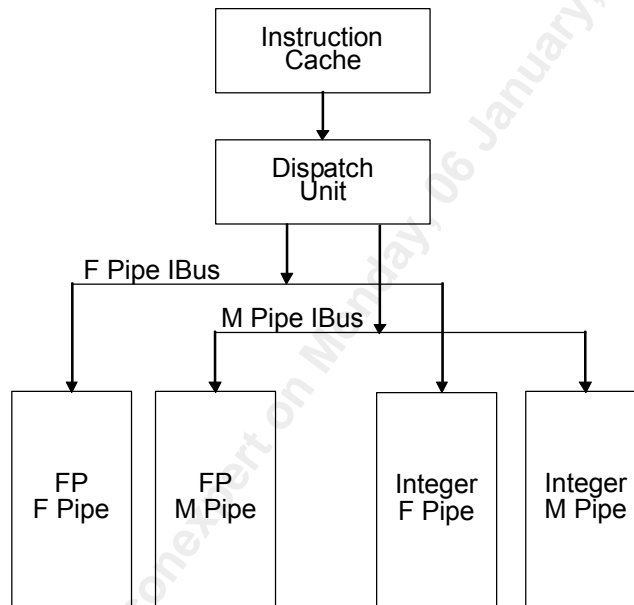

The figure illustrates that one F pipe instruction and one M pipe instruction can be issued concurrently but that two M pipe or two F pipe instructions cannot be issued. Table 2 specifies more completely the instructions within each class.

**Table 2 Dual Issue Instruction Classes**

Integer	Load/Store	Floating-point	Branch
add, sub, or, xor, shift, etc.	lw, sw, ld, sd, ldc1, sdc1, mov, movc, fmov, etc.	fadd, fsub, fmult, fmadd, fdiv, fcmp, fsqrt, etc.	beq, bne, bCzT, bCzF, j, etc.

### 4.3 Pipeline

The logical length of both the F and M pipelines is five stages with state committing (result of instruction written back into register file) in the register write or W pipe stage. The physical length of the floating-point execution pipeline is actually seven stages but this is completely transparent to the user.

Figure 4 shows instruction execution within the RM7000A when instructions are issuing simultaneously down both pipelines. As illustrated in the figure, up to ten instructions can be executing simultaneously. This figure presents a somewhat simplistic view of the processors operation since the out-of-order completion of loads, stores, and long latency floating-point operations can result in there being even more instructions in process than what is shown.

**Figure 4 Pipeline**

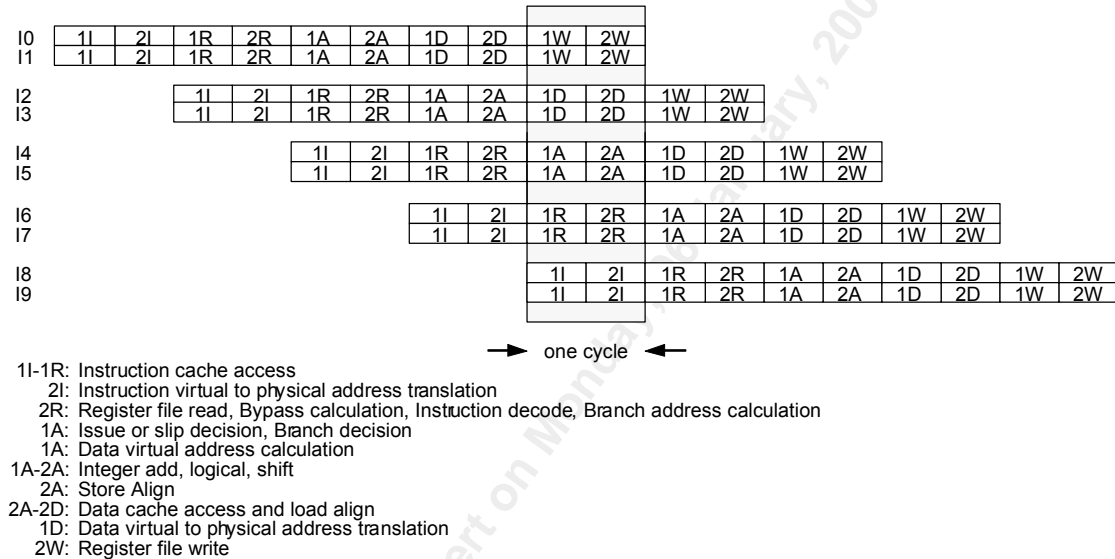

Note that instruction dependencies, resource conflicts, and branches may result in some of the instruction slots being occupied by NOPs.

## 4.4 Integer Unit

The RM7000A implements the MIPS IV™ Instruction Set Architecture. Additionally, the RM7000A includes two implementation specific instructions not found in the baseline MIPS IV ISA, but that are useful in the embedded market place. These instructions are integer multiply-accumulate (MAD) and three-operand integer multiply (MUL).

The RM7000A integer unit includes thirty-two general purpose 64-bit registers, the *HI/LO* result registers for two-operand integer multiply/divide operations, and the program counter, or PC. There are two separate execution units, one of which can execute F pipe instructions and one which can execute M pipe instructions. Refer to Table 1 for the instruction issue rules.

Note that integer multiply/divide instructions, as well as their corresponding MFHi and MFLO instructions, can only be executed in the F pipe execution unit. Within each execution unit the operational characteristics are the same as on previous MIPS designs with single cycle ALU operations (add, sub, logical, shift), one cycle load delay, and an autonomous multiply/divide unit.

## Register File

The RM7000A has thirty-two general purpose registers with register location 0 (*r0*) hard wired to a zero value. These registers are used for scalar integer operations and address calculation. In order to service the two integer execution units, the register file has four read ports and two write ports and is fully bypassed both within and between the two execution units to minimize operation latency in the pipeline.

## 4.5 ALU

The RM7000A has two complete integer ALUs each consisting of an integer adder/subtractor, a logic unit, and a shifter. Table 3 shows the functions performed by the ALUs for each execution unit. Each of these units is optimized to perform all operations in a single processor cycle.

**Table 3 ALU Operations**

Unit	F Pipe	M Pipe
Adder	add, sub	add, sub, data address add
Logic	logic, moves, zero shifts (nop)	logic, moves, zero shifts (nop)
Shifter	non-zero shift	non-zero shift, store align

## 4.6 Integer Multiply/Divide

The RM7000A has a single dedicated integer multiply/divide unit optimized for high-speed multiply and multiply-accumulate operations. The multiply/divide unit resides in the F pipe execution unit. Table 4 shows the performance of the multiply/divide unit on each operation.

**Table 4 Integer Multiply/Divide Operations**

Opcode	Operand Size	Latency	Repeat Rate	Stall Cycles
MULT/U, MAD/U	16 bit	4	3	0
	32 bit	5	4	0
MUL	16 bit	4	3	2
	32 bit	5	4	3
DMULT, DMULTU	any	9	8	0
DIV, DIVD	any	36	36	0
DDIV, DDIVU	any	68	68	0

The baseline MIPS IV ISA specifies that the results of a multiply or divide operation be placed in the *Hi* and *Lo* registers. These values can then be transferred to the general purpose register file using the Move-from-Hi and Move-from-Lo (MFHI/MFLO) instructions.

In addition to the baseline MIPS IV integer multiply instructions, the RM7000A also implements the 3-operand multiply instruction, *MUL*. This instruction specifies that the multiply result go directly to the integer register file rather than the *Lo* register. The portion of the multiply that would have normally gone into the *Hi* register is discarded. For applications where it is known that the upper half of the multiply result is not required, using the *MUL* instruction eliminates the necessity of executing an explicit *MFLO* instruction.

The multiply-add instructions, *MAD* and *MADU*, multiply two operands and add the resulting product to the current contents of the *Hi* and *Lo* registers. The multiply-accumulate operation is the core primitive of almost all signal processing algorithms. Therefore, using the RM7000A eliminates the need for a separate DSP engine in many embedded applications.

## 4.7 Floating-Point Coprocessor

The RM7000A incorporates a high-performance fully pipelined floating-point co-processor that includes a floating-point register file and autonomous execution units for multiply/add/ convert and divide/square root. The floating-point coprocessor is a tightly coupled execution unit, decoding and executing instructions in parallel with, and in the case of floating-point loads and stores, in cooperation with the M pipe of the integer unit. The superscalar capabilities of the RM7000A allow floating-point computation instructions to issue concurrently with integer instructions.

## 4.8 Floating-Point Unit

The RM7000A floating-point execution unit supports single and double precision arithmetic, as specified in the IEEE Standard 754. The execution unit is broken into a separate divide/square root unit and a pipelined multiply/add unit. Overlap of divide/square root and multiply/add is supported.

The RM7000A maintains fully precise floating-point exceptions while allowing both overlapped and pipelined operations. Precise exceptions are extremely important in object-oriented programming environments and highly desirable for debugging in any environment.

Floating-point operations include:

- add
- subtract
- multiply
- divide
- square root
- reciprocal
- reciprocal square root
- conditional moves
- conversion between fixed-point and floating-point format

- conversion between floating-point formats
- floating-point compare

Table 5 gives the latencies of the floating-point instructions in internal processor cycles.

**Table 5 Floating Point Latencies and Repeat Rates**

Operation	Latency single/double	Repeat Rate single/double
fadd	4	1
fsub	4	1
fmult	4/5	1/2
fmadd	4/5	1/2
fmsub	4/5	1/2
fdiv	21/36	19/34
fsqrt	21/36	19/34
frecip	21/36	19/34
frsqrt	38/68	36/66
fcvt.s.d	4	1
fcvt.s.w	6	3
fcvt.s.l	6	3
fcvt.d.s	4	1
fcvt.d.w	4	1
fcvt.d.l	4	1
fcvt.w.s	4	1
fcvt.w.d	4	1
fcvt.l.s	4	1
fcvt.l.d	4	1
fcmp	1	1
fmov, fmovc	1	1
fabs, fneg	1	1

## 4.9 Floating-Point General Register File

The floating-point general register file (FGR) is made up of thirty-two 64-bit registers. With the floating-point load and store double instructions, LDC1 and SDC1, the floating-point unit can take advantage of the 64-bit wide data cache and issue a floating-point coprocessor load or store doubleword instruction in every cycle.

The floating-point control register file contains two registers; one for determining configuration and revision information for the coprocessor, and one for control and status information. These registers are primarily used for diagnostic software, exception handling, state saving and restoring, and control of rounding modes.

To support superscalar operations the FGR has four read ports and two write ports and is fully bypassed to minimize operation latency in the pipeline. Three of the read ports and one write port are used to support the combined multiply-add instruction while the fourth read and second write port allows for concurrent floating-point load or store and conditional move operations.

#### 4.10 System Control Coprocessor (CP0)

The system control coprocessor (CP0) is responsible for the virtual memory sub-system, the exception control system, and the diagnostics capability of the processor.

For memory management support, the RM7000A CP0 is logically identical to the RM5200 Family. For interrupt exceptions and diagnostics, the RM7000A is a superset of the RM5200 Family, implementing additional features described in the following sections on Interrupts, Test/Breakpoint registers, and Performance Counters.

The memory management unit controls the virtual memory system page mapping. It consists of an instruction address translation buffer (ITLB) a data address translation buffer (DTLB), a Joint TLB (JTLB), and coprocessor registers used by the virtual memory mapping sub-system.

#### 4.11 System Control Coprocessor Registers

The RM7000A incorporates all CP0 registers internally. These registers provide the path through which the virtual memory system's page mapping is examined and modified, exceptions are handled, and operating modes are controlled (kernel vs. user mode, interrupts enabled or disabled, cache features). In addition, the RM7000A includes registers to implement a real-time cycle counting facility, to aid in cache and system diagnostics, and to assist in data error detection.

To support the non-blocking caches and enhanced interrupt handling capabilities of the RM7000A, both the data and control register spaces of CP0 are supported. In the data register space, which is accessed using the MFC0 and MTC0 instructions, the RM7000A supports the same registers as found in previous RM7000 processors. In the control space, which is accessed by the previously unused CTC0 and CFC0 instructions, the RM7000A supports five additional registers. The first three of these new 32-bit registers support the enhanced interrupt handling capabilities; *Interrupt Control*, *Interrupt Priority Level Lo (IPLLO)*, and *Interrupt Priority Level Hi (IPLHI)*. These registers are described further in the section on interrupt handling. Two other registers, *Imprecise Error 1* and *Imprecise Error 2*, have been added to help diagnose bus errors that occur on non-blocking memory references.

Figure 5 shows the CP0 registers.

Figure 5 CP0 Registers

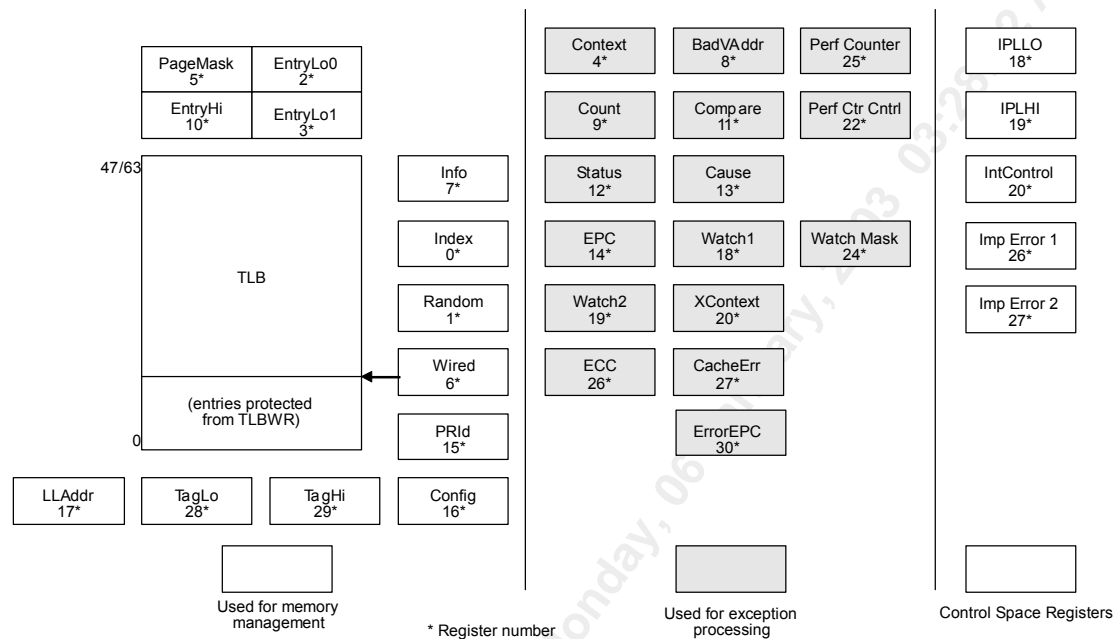

## 4.12 Virtual to Physical Address Mapping

The RM7000A provides three modes of virtual addressing:

- user mode
- kernel mode
- supervisor mode

These modes allow system software to provide a secure environment for user processes. Bits in the CP0 *Status* register determine which virtual addressing mode is used. In user mode, the RM7000A provides a single, uniform virtual address space of 256 GB (2 GB in 32-bit mode).

When operating in the kernel mode, four distinct virtual address spaces, totaling 1024 GB (4 GB in 32-bit mode), are simultaneously available and are differentiated by the high-order bits of the virtual address.

The RM7000A processor also supports a supervisor mode in which the virtual address space is 256.5 GB (2.5 GB in 32-bit mode), divided into three regions based on the high-order bits of the virtual address. Figure 6 shows the address space layout for 32-bit operations.

**Figure 6 Kernel Mode Virtual Addressing (32-bit)**

0xFFFFFFFF	Kernel virtual address space
	(kseg3)
0xE0000000	Mapped, 0.5GB
0xDFFFFFFF	Supervisor virtual address space
	(ksegs)
0xC0000000	Mapped, 0.5GB
0xBFFFFFFF	Uncached kernel physical address space
	(kseg1)
0xA0000000	Unmapped, 0.5GB
0x9FFFFFFF	Cached kernel physical address space
	(ksegs)
0x80000000	Unmapped, 0.5GB
0x7FFFFFFF	User virtual address space
	(kusegs)
0x00000000	Mapped, 2.0GB

When the RM7000A is configured for 64-bit addressing, the virtual address space layout is an upward compatible extension of the 32-bit virtual address space layout.

### 4.13 Joint TLB

For fast virtual-to-physical address translation, the RM7000A uses a large, fully associative TLB that maps virtual pages to their corresponding physical addresses. As indicated by its name, the JTLB is used for both instruction and data translations. The JTLB is organized as pairs of even/ odd entries, and maps a virtual address and address space identifier (ASID) into the large, 64 GB physical address space. By default, the JTLB is configured as 48 pairs of even/odd entries. The optional 64 even/odd entry configuration is set at boot time.

Two mechanisms are provided to assist in controlling the amount of mapped space and the replacement characteristics of various memory regions. First, the page size can be configured, on a per-entry basis, to use page sizes in the range of 4 KB to 16 MB (in 4x multiples). The CPO *PageMask* register is loaded with the desired page size of a mapping, and that size is stored into the TLB, along with the virtual address, when a new entry is written. Thus, operating systems can create special purpose maps; for example, an entire frame buffer can be memory mapped using only one TLB entry.

The second mechanism controls the replacement algorithm when a TLB miss occurs. The RM7000A provides a random replacement algorithm to select a TLB entry to be written with a new mapping. However, the processor also provides a mechanism whereby a system specific number of mappings can be locked into the TLB, thereby avoiding random replacement. This mechanism uses the CPO Wired register and allows the operating system to guarantee that certain pages are always mapped for performance reasons and to avoid a deadlock condition. This mechanism also facilitates the design of real-time systems by allowing deterministic access to critical software.

The JTLB also contains information that controls the cache coherency protocol for each page. Specifically, each page has attribute bits to determine whether the coherency algorithm is:

- uncached
- write-back
- write-through with write-allocate
- write-through without write-allocate
- write-back with secondary and tertiary bypass

Note that both of the write-through protocols bypass both the secondary and the tertiary caches since neither of these caches support writes of less than a complete cache line.

These protocols are used for both code and data on the RM7000A with data using write-back or write-through depending on the application. The write-through modes support the same efficient frame buffer handling as the RM5200 Family.

## 4.14 Instruction TLB

The RM7000A uses a 4-entry instruction TLB (ITLB). The ITLB offers the following advantages;

- Minimizes contention for the JTLB
- Eliminates the critical path of translating through a large associative array
- Allows instruction address and data address translations to occur in parallel
- Saves power

Each ITLB entry maps a 4 KB page. The ITLB improves performance by allowing instruction address translation to occur in parallel with data address translation. When a miss occurs on an instruction address translation by the ITLB, the least-recently used ITLB entry is filled from the JTLB. The operation of the ITLB is completely transparent to the user.

## 4.15 Data TLB

The RM7000A uses a 4-entry data TLB (DTLB) for the same reasons cited above for the ITLB. Each DTLB entry maps a 4 KB page. The DTLB improves performance by allowing data address translation to occur in parallel with instruction address translation. When a miss occurs on a data address translation, the DTLB is filled from the JTLB. The DTLB refill is pseudo-LRU; the least recently used entry of the least recently used pair of entries is filled. The operation of the DTLB is completely transparent to the user.

## 4.16 Cache Memory

The RM7000A contains integrated primary instruction and data caches that support single cycle access, as well as a large unified secondary cache with a three cycle miss penalty from the primary caches. Each primary cache has a 64-bit read path and a 128-bit write path. Both caches can be accessed simultaneously. The primary caches provide the integer and floating-point units with an aggregate bandwidth of 6.4 GB per second at an internal clock frequency of 400 MHz. During an instruction or data primary cache refill, the secondary cache can provide a 64-bit datum every cycle following the initial three cycle latency for a peak bandwidth of 3.6 GB per second. For applications requiring even higher performance, the RM7000A also has a direct interface to a large external tertiary cache.

## 4.17 Instruction Cache

The RM7000A has an integrated 16 KB, four-way set associative instruction cache that is virtually indexed and physically tagged. The effective physical index eliminates the potential for virtual aliases in the cache.

The data array portion of the instruction cache is 64 bits wide and protected by word parity while the tag array holds a 24-bit physical address, 14 control bits, a valid bit, and a single parity bit.

By accessing 64 bits per cycle, the instruction cache is able to supply two instructions per cycle to the superscalar dispatch unit. For signal processing, graphics, and other numerical code sequences where a floating-point load or store and a floating-point computation instruction are being issued together in a loop, the entire bandwidth available from the instruction cache is consumed by instruction issue. For typical integer code mixes, where instruction dependencies and other resource constraints restrict the level of parallelism that can be achieved, the extra instruction cache bandwidth is used to fetch both the taken and non-taken branch paths to minimize the overall penalty for branches.

A 32-byte (eight instruction) line size is used to maximize the communication efficiency between the instruction cache and the secondary cache, tertiary cache, or memory system.

The RM7000A supports cache locking on a per line basis. The contents of each line of the cache can be locked by setting a bit in the Tag RAM. Locking the line prevents its contents from being overwritten by a subsequent cache miss. Refills occur only into unlocked cache lines. This mechanism allows the programmer to lock critical code into the cache, thereby guaranteeing deterministic behavior for the locked code sequence.

## 4.18 Data Cache

The RM7000A has an integrated 16 KB, four-way set associative data cache that is virtually indexed and physically tagged. Line size is 32 bytes (8 words). The effective physical index eliminates the potential for virtual aliases in the cache.

The data cache is non-blocking; that is, a miss in the data cache does not necessarily stall the processor pipeline. As long as no instruction is encountered that is dependent on the data reference that caused the miss, the pipeline continues to advance. Once there are two cache misses outstanding, the processor stalls if it encounters another load or store instruction.

The data array portion of the data cache is 64 bits wide and protected by byte parity while the tag array holds a 24-bit physical address, 3 control bits, a two-bit cache state field, and two parity bits.

The most commonly used write policy is write-back, which means that a store to a cache line does not immediately cause memory to be updated. This increases system performance by reducing bus traffic and eliminating the bottleneck of waiting for each store operation to finish before issuing a subsequent memory operation. Software can, however, select write-through on a per-page basis when appropriate, such as for frame buffers. Cache protocols supported for the data cache are as follows:

1. **Uncached**

Reads to addresses in a memory area identified as uncached do not access the cache. Writes to such addresses are written directly to main memory without updating the cache.

**2. Write-back**

Loads and instruction fetches first search the cache, reading the next memory hierarchy level only if the desired data is not cache resident. On data store operations, the cache is first searched to determine if the target address is cache resident. If it is resident, the cache contents are updated and the cache line is marked for later write-back. If the cache lookup misses, the target line is first brought into the cache, after which the write is performed as above.

**3. Write-through with write allocate**

Loads and instruction fetches first search the cache, reading from memory only if the desired data is not cache resident; write-through data is never cached in the secondary or tertiary caches. On data store operations, the cache is first searched to determine if the target address is cache resident. If it is resident, the primary cache contents are updated and main memory is written, leaving the write-back bit of the cache line unchanged; no writes occur to the secondary or tertiary caches. If the cache lookup misses, the target line is first brought into the cache, after which the write is performed as above.

**4. Write-through without write allocate**

Loads and instruction fetches first search the cache, reading from memory only if the desired data is not cache resident; write-through data is never cached in the secondary or tertiary caches. On data store operations, the cache is first searched to determine if the target address is cache resident. If it is resident, the cache contents are updated and main memory is written, leaving the write-back bit of the cache line unchanged; no writes occur to the secondary or tertiary caches. If the cache lookup misses, only main memory is written.

**5. Fast Packet Cache™ (Write-back with secondary and tertiary bypass)**

Loads and instruction fetches first search the primary cache, reading from memory only if the desired data is not resident; the secondary and tertiary caches are not searched. On data store operations, the primary cache is first searched to determine if the target address is resident. If it is resident, the cache contents are updated, and the cache line marked for later write-back. If the cache lookup misses, the target line is first brought into the cache, after which the write is performed as above.

Associated with the data cache is the *store buffer*. When the RM7000A executes a Store instruction, this single-entry buffer is written with the store data while the tag comparison is performed. If the tag matches, then the data is written into the data cache in the next cycle that the data cache is not accessed (the next non-load cycle). The store buffer allows the RM7000A to execute a store every processor cycle and to perform back-to-back stores without penalty. In the event of a store immediately followed by a load to the same address, a combined merge and cache write occurs such that no penalty is incurred.

## 4.19 Secondary Cache

The RM7000A has an integrated 256 KB, four-way set associative, block write-back secondary cache. The secondary cache has a 32-byte line size, a 64-bit bus width to match the system interface and primary cache bus widths, and is protected with doubleword parity. The secondary cache tag array holds a 20-bit physical address, 2 control bits, a 3-bit cache state field, and two parity bits.

By integrating a secondary cache, the RM7000A is able to decrease the latency of a primary cache miss without significantly increasing the number of pins and the amount of power required by the processor. From a technology point of view, integrating a secondary cache leverages CMOS technology by using silicon to build the structures that are most amenable to silicon technology; building very dense, low power memory arrays rather than large power hungry I/O buffers.

Further benefits of an integrated secondary cache are flexibility in the cache organization and management policies that are not practical with an external cache. Two previously mentioned examples are the 4-way associativity and write-back cache protocol.

A third management policy for which integration affords flexibility is cache hierarchy management. With multiple levels of cache, it is necessary to specify a policy for dealing with cases where two cache lines at level  $n$  of the hierarchy could possibly be sharing an entry in level  $n+1$  of the hierarchy.

The RM7000A allows entries to be stored in the primary caches that do not necessarily have a corresponding entry in the secondary; the RM7000A does not force the primaries to be a subset of the secondary. For example, if primary cache line A is being filled and a cache line already exists in the secondary for primary cache line B at the location where primary A's line would reside, then that secondary entry is replaced by an entry corresponding to primary cache line A and no action occurs in the primary for cache line B. This operation creates the aforementioned scenario where the primary cache line, which initially had a corresponding secondary entry, no longer has such an entry. Such a primary line is called an *orphan*. In general, cache lines at level  $n+1$  of the hierarchy are called *parents* of level  $n$ 's *children*.

Another RM7000A cache management optimization occurs for the case of a secondary cache line replacement where the secondary line is dirty and has a corresponding dirty line in the primary. In this case, since it is permissible to leave the dirty line in the primary, it is not necessary to write the secondary line back to main memory. Taking this scenario one step further, a final optimization occurs when the aforementioned dirty primary line is replaced by another line and must be written back. In this case it is written directly to memory, bypassing the secondary cache.

## 4.20 Secondary Caching Protocols

Unlike the primary data cache, the secondary cache supports only block write-back. As noted earlier, cache lines managed with either of the write-through protocols are not placed in the secondary cache. A new caching attribute, *write-back with secondary and tertiary bypass*, allows the secondary, and tertiary caches to be bypassed entirely. When this attribute is selected, the secondary and tertiary caches are not filled on load misses and are not written on dirty write-backs from the primary cache.

## 4.21 Tertiary Cache

The RM7000A has direct support for an external tertiary cache. The tertiary cache is direct mapped and block write-through with byte parity protection for data. The RM7000A tertiary cache operates identical to the secondary cache of the RM527x while supporting additional size increments to support 4 MB and 8 MB caches.

The tertiary interface uses the **SysAD** bus for data and tags while providing a separate bus, **TcLine[17:0]**, for addresses, along with a number of tertiary cache specific control signals.

A tertiary read looks nearly identical to a standard processor read except that the tag chip enable signal, **TcTCE\***, is asserted concurrently with **ValidOut\*** and **Release\***, initiating a tag probe and indicating to the external agent that a tertiary cache access is being performed. As a result, the external agent monitors the tertiary hit signal, **TcMatch**. If a hit is indicated the external agent aborts the memory read and refrains from acquiring control of the system interface. Along with **TcTCE\***, the processor also asserts the tag data enable signal, **TcTDE\***, which causes the tag RAMs to latch the **SysAD** address internally for use as the replacement tag if a cache miss occurs.

On a tertiary cache miss, a refill is accomplished with a two signal handshake between the data output enable signal, **TcDOE\***, which is deasserted by the external agent, and the tag and data write enable signal, **TcCWE\***, asserted by the processor. Figure 7 illustrates a tertiary cache hit followed by a miss.

**Figure 7 Tertiary Cache Hit and Miss**

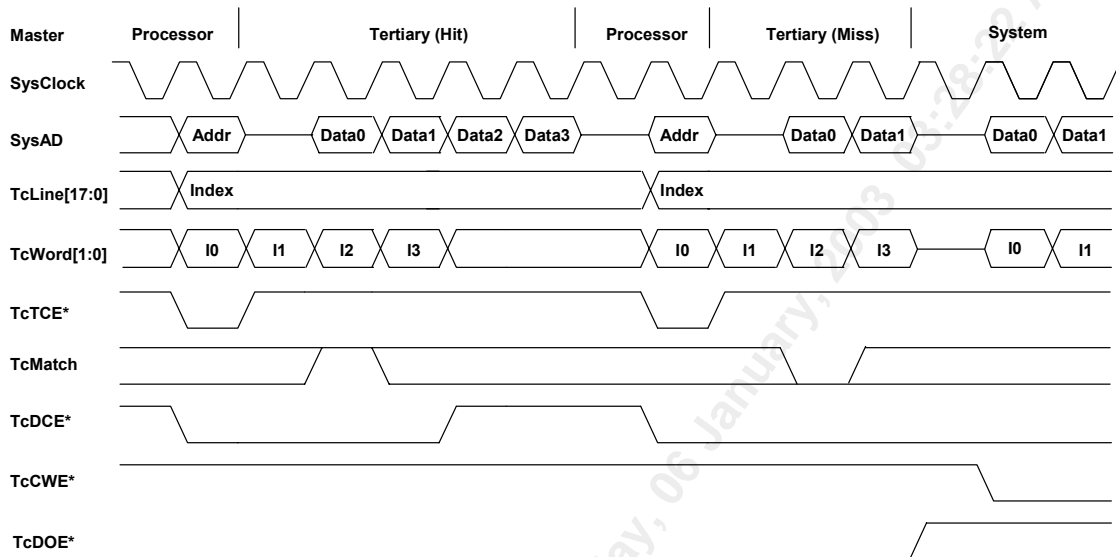

Other capabilities of the tertiary interface include block write, tag invalidate, and tag probe. For details of these transactions as well as detailed timing waveforms for all the tertiary cache transactions, refer to the RM7000 Family User Manual. The tertiary cache tag can easily be implemented with standard components such as the Motorola MCM69T618.

The RM7000A cache attributes for the instruction, data, internal secondary, and optional external tertiary caches are summarized in Table 6.

**Table 6 Cache Attributes**

Attribute	Primary Instruction	Primary Data	On-chip Secondary	Tertiary Cache
Size	16KB	16KB	256KB	512K, 1M, 2M, 4M, or 8M
Associativity	4-way	4-way	4-way	direct mapped
Replacement Algorithm	cyclic	cyclic	cyclic	direct replacement
Line size	32 byte	32 byte	32 byte	32 byte
Index	vAddr <sub>11..0</sub>	vAddr <sub>11..0</sub>	pAddr <sub>15..0</sub>	pAddr <sub>22..0</sub>
Tag	pAddr <sub>35..12</sub>	pAddr <sub>35..12</sub>	pAddr <sub>35..16</sub>	pAddr <sub>35..19</sub>
Write policy	n.a.	write-back, write-through	block write-back, bypass	block write-through, bypass
read policy	n.a.	non-blocking (2 outstanding)	non-blocking (data only, 2 outstanding)	non-blocking (data only, 2 outstanding)
read order	critical word first	critical word first	critical word first	critical word first
write order	NA	sequential	sequential	sequential

Attribute	Primary Instruction	Primary Data	On-chip Secondary	Tertiary Cache
miss restart following:	complete line	first double (if waiting for data)	n.a.	n.a.
Parity	per word	per byte	per doubleword	per byte

## 4.22 Cache Locking

The RM7000A allows critical code or data fragments to be locked into the primary and secondary caches. The user has complete control over the locking function. For instruction and data fragments in the primary caches, locking is accomplished by setting either or both of the cache lock enable bits and specifying the set in the CP0 ECC register, then executing either a load instruction for data, or a Fill\_I cache operation for instructions.

Only cache lines within sets A and B of each cache can be locked. Locking within the secondary works identically to the primaries using a separate secondary lock enable bit and the same set selection field. As with the primaries, only sets A and B can be locked. Table 7 summarizes the cache locking capabilities.

**Table 7 Cache Locking Control**

Cache	Lock Enable	Set Select	Activate
Primary I	ECC[27]	ECC[28]=0A ECC[28]=1B	Fill_I
Primary D	ECC[26]	ECC[28]=0A ECC[28]=1B	Load/Store
Secondary	ECC[25]	ECC[28]=0A ECC[28]=1B	Fill_I or Load/Store

## 4.23 Cache Management

To improve the performance of critical data movement operations in the embedded environment, the RM7000A significantly improves the speed of operation of certain critical cache management operations. In particular, the speed of the Hit-Writeback-Invalidate and Hit-Invalidate cache operations has been improved, in some cases by an order of magnitude, over that of other MIPS processors. For example, Table 8 compares the RM7000A with the R4000 processor.

**Table 8 Penalty Cycles**

Operation	Condition	Penalty	
		RM7000A	R4000
Hit-Writeback- Invalidate	Miss	0	7
	Hit-Clean	3	12
	Hit-Dirty	3+n	14+n
Hit-Invalidate	Miss	0	7
	Hit	2	9

For the Hit-Dirty case of Hit-Writeback-Invalidate in Table 8 above, if the writeback buffer is full from some previous cache eviction, then n is the number of cycles required to empty the writeback buffer. If the buffer is empty then n is zero.

The penalty value in Table 8 is the number of processor cycles beyond the one cycle required to issue the instruction that is required to implement the operation.

## 4.24 Primary Write Buffer

Writes to secondary cache or external memory, whether cache miss write-backs or stores to uncached or write-through addresses, use the integrated primary write buffer. The write buffer holds up to four 64-bit address and data pairs. The entire buffer is used for a data cache write-back and allows the processor to proceed in parallel with memory update. For uncached and write-through stores, the write buffer significantly increases performance by decoupling the SysAD bus transfers from the instruction execution stream.

## 4.25 System Interface

The RM7000A provides a high-performance 64-bit system interface that is compatible with the RM5200 Family. As an enhancement to the system interface, the RM7000A allows half-integral clock multipliers, thereby providing greater granularity when selecting pipeline and system interface frequencies.

The system interface consists of a 64-bit Address/Data bus with 8 check bits and a 9-bit command bus. In addition, there are ten handshake signals and ten interrupt inputs. The interface is capable of transferring data between the processor and memory at a peak rate of 1000 MB/sec with a 125 MHz SysClock.

Figure 8 shows a typical embedded system using the RM7000A. This example shows a system with a bank of DRAMs, an optional tertiary cache, and an interface ASIC which provides DRAM control as well as an I/O port.

Figure 8 Typical Embedded System Block Diagram

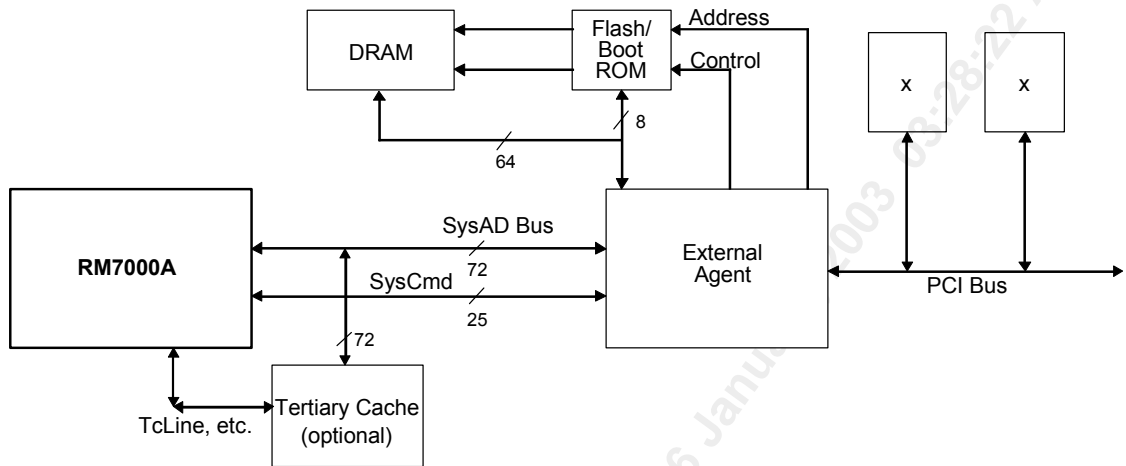

## 4.26 System Address/Data Bus

The 64-bit System Address Data (**SysAD**) bus is used to transfer addresses and data between the RM7000A and the rest of the system. It is protected with an 8-bit parity check bus, **SysADC[7:0]**.

The system interface is configurable to allow easy interfacing to memory and I/O systems of varying frequencies. The data rate and the bus frequency at which the RM7000A transmits data to the system interface are programmable at boot time via mode control bits. In addition, the rate at which the processor receives data is fully controlled by the external agent. Therefore, either a low cost interface requiring no read or write buffering, or a faster, high-performance interface can be designed to communicate with the RM7000A.

## 4.27 System Command Bus

The RM7000A interface has a 9-bit System Command bus, **SysCmd[8:0]**. The command bus indicates whether the **SysAD** bus carries address or data information on a per-clock basis. If the **SysAD** bus carries address, the **SysCmd** bus indicates the transaction type (for example, a read or write). If the **SysAD** bus carries data, then the **SysCmd** bus contains information about the data (for example, this is the last data word transmitted, or the data contains an error). The **SysCmd** bus is bidirectional to support both processor requests and external requests to the RM7000A. Processor requests are initiated by the RM7000A and responded to by an external agent. External requests are issued by an external agent and require the RM7000A to respond.

The RM7000A supports one- to eight-byte transfers as well as 32-byte block transfers on the **SysAD** bus. In the case of a sub-doubleword transfer, the 3 low-order address bits give the byte address of the transfer, and the **SysCmd** bus indicates the number of bytes being transferred.

## 4.28 Handshake Signals

There are ten handshake signals on the system interface. Two of these, **RdRdy\*** and **WrRdy\***, are driven by an external agent to indicate to the RM7000A whether it can accept a new read or write transaction. The RM7000A samples these signals before deasserting the address on read and write requests.

**ExtRqst\*** and **Release\*** are used to transfer control of the **SysAD** and **SysCmd** buses from the processor to an external agent. When an external agent requires control of the bus, it asserts **ExtRqst\***. The RM7000A responds by asserting **Release\*** to release the system interface to slave state.

**PRqst\*** and **PAck\*** are used to transfer control of the **SysAD** and **SysCmd** buses from the external agent to the processor. These two pins have been added to the system interface to support multiple outstanding reads and facilitate non-blocking cache operations. When the processor needs to reacquire control of the interface, it asserts **PRqst\***. The external agent responds by asserting **PAck\*** to return control of the interface to the processor.

**RspSwap\*** is used by the external agent to indicate to the processor when it is returning multiple data out of order. For example, when there are two outstanding reads, the external agent asserts **RspSwap\*** when it is going to return the data for the second read before it returns the data for the first read. **RspSwap\*** must be asserted by the external agent two cycles ahead of when it presents data so that the processor has time to switch to the correct address for writes into the tertiary cache.

**RdType** is another new pin on the interface that indicates whether a read is an instruction read or a data read. When asserted, the reference is an instruction read. When deasserted it is a data read. **RdType** is only valid during valid address cycles.

**ValidOut\*** and **ValidIn\*** are used by the RM7000A and the external agent respectively to indicate that there is a valid command and data on the **SysAD** and **SysCmd** buses. The RM7000A asserts **ValidOut\*** when it is driving these buses with a valid command and data, and the external agent drives **ValidIn\*** when it has control of the system interface and is driving a valid command and data.

## 4.29 System Interface Operation

To support non-blocking caches and data prefetch instructions, the RM7000A allows two outstanding reads. An external agent may respond to read requests in whatever order it chooses by using the response order indicator pin **RspSwap\***. No more than two read requests are submitted to the external agent. Support for multiple outstanding reads can be enabled or disabled via a boot-time mode bit. Refer to Table 16 for a complete list of mode bits.

The RM7000A can issue read and write requests to an external agent, while an external agent can issue null and read responses to the RM7000A.

For processor reads, the RM7000A asserts **ValidOut\*** and simultaneously drives the address and read command on the **SysAD** and **SysCmd** buses. If the system interface has **RdRdy\*** asserted, then the processor tristates its drivers and releases the system interface to slave state by asserting **Release\***. The external agent can then begin sending data to the RM7000A.

Figure 9 shows a processor block read request and the external agent read response for a system with either no tertiary cache or a transaction where the tertiary is being bypassed.

**Figure 9 Processor Block Read**

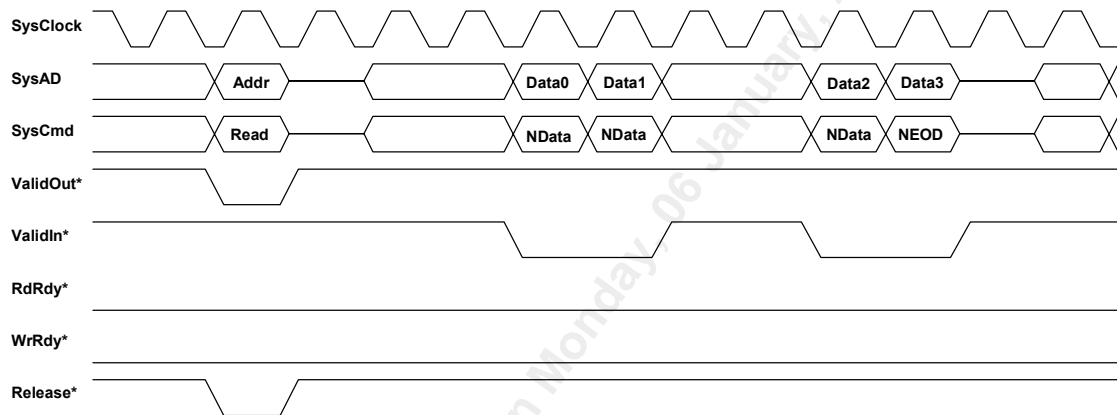

In Figure 9 the read latency is 4 cycles (**ValidOut\*** to **ValidIn\***), and the response data pattern is DDxxDD. Figure 10 shows a processor block write where the processor was programmed with write-back data rate boot code 2, or DDxxDDxx.

Figure 11 shows a typical sequence resulting in two outstanding reads both with initial tertiary cache accesses, as explained in the following sequence.

1. The processor issues a read that misses in the tertiary cache.
2. The external agent takes control of the bus in preparation for returning data to the processor.
3. The processor encounters another internal cache miss and therefore asserts **PRqst\*** in order to regain control of the bus.
4. The external agent pulses **PAck\***, returning control of the bus to the processor.
5. The processor issues a read for the second miss.
6. The second cycle also misses in the tertiary.
7. The **RspSwap\*** pin is asserted to denote the out of order response. Not shown in the figure is the completion of the data transfer for the second miss, or any of the data transfer for the first miss.

- The external agent retakes control of the bus and begins returning data (out of order) for the second miss to the processor

**Figure 10 Processor Block Write**

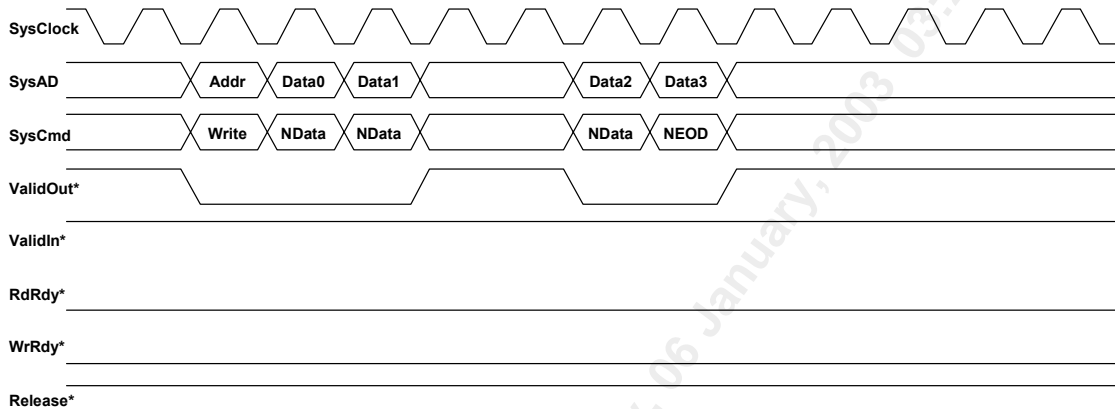

**Figure 11 Multiple Outstanding Reads**

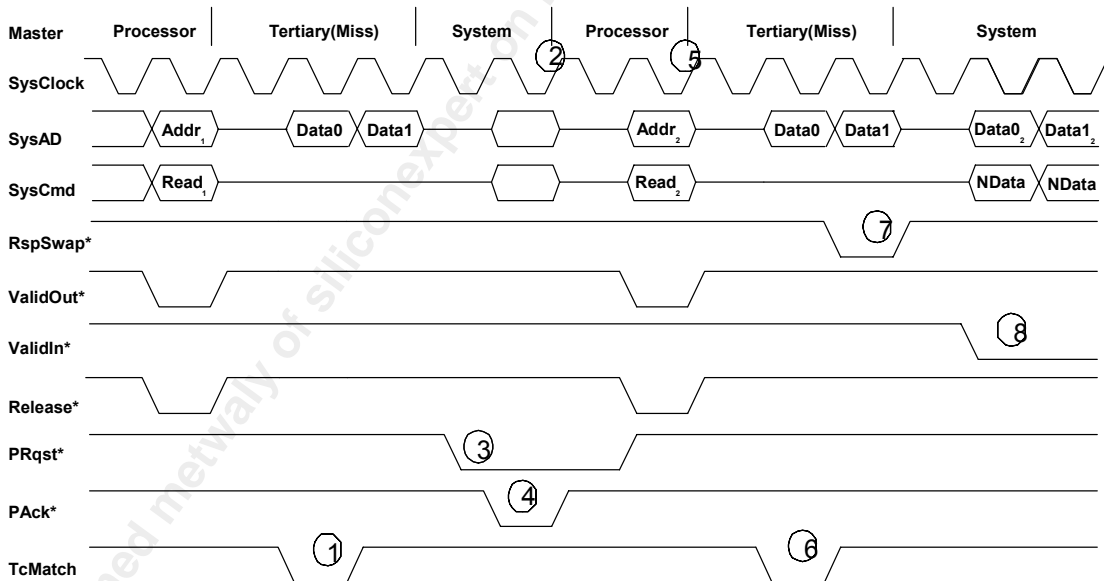

### 4.30 Data Prefetch

The RM7000A supports the MIPS IV integer data prefetch (PREF) and floating-point data prefetch (PREFX) instructions. These instructions are used by the compiler or by an assembly language programmer when it is known or suspected that an upcoming data reference is going to miss in the cache. By appropriately placing a prefetch instruction, the memory latency can be hidden under the execution of other instructions. In cases where the execution of a prefetch instruction would cause a memory management or address error exception the prefetch is treated as a NOP.

The “Hint” field of the data prefetch instruction is used to specify the action taken by the instruction. The instruction can operate normally (that is, fetching data as if for a load operation) or it can allocate and fill a cache line with zeroes on a primary data cache miss.

### 4.31 Enhanced Write Modes

The RM7000A implements two enhancements to the original R4000 write mechanism: Write Reissue and Pipeline Writes. The original R4000 allowed a write on the **SysAD** bus every four **SysClock** cycles. Hence for a non-block write, this meant that two out of every four cycles were wait states.

Pipelined write mode eliminates these two wait states by allowing the processor to drive a new write address onto the bus immediately after the previous data cycle. This allows for higher **SysAD** bus utilization. However, at high frequencies the processor may drive a subsequent write onto the bus prior to the time the external agent deasserts **WrRdy\***, indicating that it can not accept another write cycle. This can cause the cycle to be missed.

Write reissue mode is an enhancement to pipelined write mode and allows the processor to reissue missed write cycles. If **WrRdy\*** is deasserted during the issue phase of a write operation, the cycle is aborted by the processor and reissued at a later time.

In write reissue mode, a rate of one write every 2 bus cycles can be achieved. Pipelined writes have the same two bus cycle write repeat rate, but can issue one additional write following the deassertion of **WrRdy\***.

### 4.32 External Requests

The RM7000A can respond to certain requests issued by an external agent. These requests take one of two forms: Write requests and Null requests. An external agent executes a *write* request when it wishes to update one of the processors writable resources such as the internal interrupt register. A *null* request is executed when the external agent wishes the processor to reassert ownership of the processor external interface. Once the external agent has acquired control of the processor interface via **ExtRqst\***, it can execute a null request after completing an independent transaction between itself and system memory in a system where memory is connected directly to the **SysAD** bus. Normally this transaction would be a DMA read or write from the I/O system.

### 4.33 Test/Breakpoint Registers

To facilitate hardware and software debugging, the RM7000A incorporates a pair of Test/Breakpoint, or Watch registers, called *Watch1* and *Watch2*. Each Watch register can be separately enabled to watch for a load address, a store address, or an instruction address. All address comparisons are done on physical addresses. An associated register, *Watch Mask*, has also been added so that either or both of the Watch registers can compare against an address range rather than a specific address. The range granularity is limited to a power of two.

When enabled, a match of either Watch register results in an exception. If the Watch is enabled for a load or store address then the exception is the Watch exception as defined for the R4000 by Cause exception code 23. If the Watch is enabled for instruction addresses then a newly defined *Instruction Watch* exception is taken and the Cause code is 16. The Watch register which caused the exception is indicated by *Cause[25:24]*. Table 9 summarizes a Watch operation.

**Table 9 Watch Control Register**

Register	Bit Field/Function					
	63	62	61	[60:36]	[35:2]	[1:0]
Watch1, 2	Store	Load	Instr	0	Addr	0
	[31:2]				1	0
Watch Mask	Mask				Mask Watch2	Mask Watch1

**Note**

1. The *W1* and *W2* bits of the *Cause* register indicate which Watch register caused a particular Watch exception.

### 4.34 Performance Counters

To facilitate system tuning, the RM7000A implements a performance counter using two new CPO registers, *PerfCount* and *PerfControl*. The *PerfCount* register is a 32-bit writable counter that causes an interrupt when bit 31 is set. The *PerfControl* register is a 32-bit register containing a 5-bit field that selects one of twenty-two event types as well as a handful of bits that control the overall counting function. Note that only one event type can be counted at a time and that counting can occur for user code, kernel code, or both. The event types and control bits are listed in Table 10.

**Table 10 Performance Counter Control**

PerfControl Field	Description
[4:0]	Event Type 00: Clock cycles 01: Total instructions issued 02: Floating-point instructions issued 03: Integer instructions issued 04: Load instructions issued 05: Store instructions issued 06: Dual issued pairs 07: Branch prefetches 08: External Cache Misses 09: Stall cycles 0A: Secondary cache misses 0B: Instruction cache misses 0C: Data cache misses 0D: Data TLB misses 0E: Instruction TLB misses 0F: Joint TLB instruction misses 10: Joint TLB data misses 11: Branches taken 12: Branches issued 13: Secondary cache writebacks 14: Primary cache writebacks 15: Dcache miss stall cycles (cycles where both cache miss tokens taken and a third address is requested) 16: Cache misses 17: FP possible exception cycles 18: Slip Cycles due to multiplier busy 19: Coprocessor 0 slip cycles 1A: Slip cycles due to pending non-blocking loads 1B: Write buffer full stall cycles 1C: Cache instruction stall cycles 1D: Multiplier stall cycles 1E: Stall cycles due to pending non-blocking loads - stall start of exception
[7:5]	Reserved (must be zero)
8	Count in Kernel Mode 0: Disable 1: Enable

PerfControl Field	Description
9	Count in User Mode 0: Disable 1: Enable
10	Count Enable 0: Disable 1: Enable
[31:11]	Reserved (must be zero)

The performance counter interrupt only occurs when interrupts are enabled in the *Status.IE* is 1, and the Interrupt Mask bit 13 (*IM13*) of the coprocessor 0 interrupt control register is set.

Since the performance counter can be set up to count clock cycles, it can be used as either a second timer, or a watchdog interrupt. A watchdog interrupt can be used as an aid in debugging system or software “hangs.” Typically the software is setup to periodically update the count so that no interrupt occurs. When a hang occurs the interrupt ultimately triggers, thereby breaking free from the hang-up.

### 4.35 Interrupt Handling

In order to provide better real time interrupt handling, the RM7000A provides an extended set of hardware interrupts, each of which can be separately prioritized and separately vectored.

In addition to the standard six external interrupt pins, the RM7000A provides four more interrupt pins for a total of ten external interrupts.

As described above, the performance counter is also a hardware interrupt source using **INT13**. Historically in the MIPS architecture, interrupt 7 (**INT7**) was used as the Timer Interrupt. The RM7000A provides a separate interrupt, **INT12**, for this purpose, thereby releasing **INT7** for use as a pure external interrupt.

All interrupts (**INT[13:0]**), the Performance Counter, and the Timer, have corresponding interrupt mask bits, *IM[13:0]*, and interrupt pending bits, *IP[13:0]*, in the *Status*, *Interrupt Control*, and *Cause* registers. The bit assignments for the *Interrupt Control* and *Cause* registers are shown in Table 11 and Table 12. The *Status* register has not changed from the RM5200 Family and is not shown.

The *IV* bit in the *Cause* register is the global enable bit for the enhanced interrupt features. If this bit is clear then interrupt operation is compatible with the RM5200 Family.

In the *Interrupt Control* register, the interrupt vector spacing is controlled by the Spacing field as described below. The Interrupt Mask field (*IM[13:8]*) contains the interrupt mask for interrupts eight through thirteen. *IM[15:14]* are reserved for future use.

The Timer Enable (*TE*) bit is used to gate the Timer Interrupt to the *Cause* Register. If *TE* is set to 0, the Timer Interrupt is not gated to *IP12*. If *TE* is set to 1, the Timer Interrupt is gated to *IP12*.

The setting for Mode Bit 11 is used to determine if the Timer Interrupt replaces the external interrupt (*INT5\**) as an input to *IP7* in the *Cause* Register. If Mode Bit 11 is set to 0, the Timer Interrupt is gated to *IP7*. If Mode Bit 11 is set to 1, external *INT5\** is gated to *IP7*.

In order to utilize both the external Interrupt (*INT5\**) and the internal Timer Interrupt, Mode Bit 11 must be set to 1, and *TE* must be set to 1. In this case, the Timer Interrupt will utilize *IP12*, and *INT5\** will utilize *IP7*. Please also reference the logic diagram for interrupt signals in the RM7000 User Manual.

The *Interrupt Control* register uses IM13 to enable the Performance Counter Control.

Priority of the interrupts is set via two new coprocessor 0 registers called *Interrupt Priority Level Lo (IPLLO)* and *Interrupt Priority Level Hi (IPLHI)*.

**Table 11 Cause Register**

<b>31</b>	<b>30</b>	<b>[29:28]</b>	<b>27</b>	<b>26</b>	<b>25</b>	<b>24</b>	<b>[23:8]</b>	<b>7</b>	<b>[6:2]</b>	<b>[1:0]</b>
BD	0	CE	0	W2	W1	IV	IP[15:0]	0	EXC	0

**Table 12 Interrupt Control Register**

<b>[31:16]</b>	<b>[15:8]</b>	<b>7</b>	<b>[6:5]</b>	<b>[4:0]</b>
0	IM[15:8]	TE	0	Spacing

**Table 13 IPLLO Register**

<b>[31:28]</b>	<b>[27:24]</b>	<b>[23:20]</b>	<b>[19:16]</b>	<b>[15:12]</b>	<b>[11:8]</b>	<b>[7:4]</b>	<b>[3:0]</b>
IPL7	IPL6	IPL5	IPL4	IPL3	IPL2	IPL1	IPL0

**Table 14 IPLHI Register**

<b>[31:28]</b>	<b>[27:24]</b>	<b>[23:20]</b>	<b>[19:16]</b>	<b>[15:12]</b>	<b>[11:8]</b>	<b>[7:4]</b>	<b>[3:0]</b>
0	0	IPL13	IPL12	IPL11	IPL10	IPL9	IPL8

In the *IPLLO* and *IPLHI* registers, each interrupt is represented by a four-bit field, thereby allowing each interrupt to be programmed with a priority level from 0 to 15 inclusive. The priorities can be set in any manner, including having all the priorities set exactly the same. Priority 0 is the highest level and priority 15 the lowest. The format of the priority level registers is shown in Table 13 and Table 14 above. The priority level registers are located in the coprocessor 0 control register space.

In addition to programmable priority levels, the RM7000A also permits the spacing between interrupt vectors to be programmed. For example, the minimum spacing between two adjacent vectors is 0x20 while the maximum is 0x200. This programmability allows the user to either set up the vectors as jumps to the actual interrupt service routines or, if interrupt latency is not paramount, to include the entire interrupt service routine at one vector. Table 15 illustrates the complete set of vector spacing selections along with the coding as required in **Interrupt Control[4:0]**.

In general, the active interrupt priority, combined with the spacing setting, generates a vector offset that is then added to the interrupt base address of 0x200 to generate the interrupt exception offset. This offset is then added to the exception base to produce the final interrupt vector address.

**Table 15 Interrupt Vector Spacing**

ICR[4:0]	Spacing
0x0	0x000
0x1	0x020
0x2	0x040
0x4	0x080
0x8	0x100
0x10	0x200
others	reserved

### 4.36 Standby Mode

The RM7000A provides a means to reduce the amount of power consumed by the internal core when the CPU is not performing any useful operations. This state is known as Standby Mode.

Executing the WAIT instruction enables interrupts and causes the processor to enter Standby Mode. If the SysAD bus is currently idle when the WAIT instruction completes the W pipe stage, the internal processor clock stops, thereby freezing the pipeline. The phase lock loop, or PLL, internal timer/counter, and the "wake up" input pins: INT[9:0]\*, NMI\*, ExtReq\*, Reset\*, and ColdReset\* continue to operate in their normal fashion.

If the SysAD bus is not idle when the WAIT instruction completes the W pipe stage, then the WAIT is treated as a NOP. Once the processor is in Standby, any interrupt, including the internally generated Timer Interrupt, causes the processor to exit Standby and resume operation where it left off. The WAIT instruction is typically inserted in the idle loop of the operating system or real time executive.

### 4.37 JTAG Interface

The RM7000A interface supports JTAG boundary scan in conformance with IEEE 1149.1. The JTAG interface is useful for checking the integrity of the processor's pin connections.

## 4.38 Boot-Time Options

The RM7000A operating modes are initialized at power-up by the boot-time mode control interface. The serial boot-time mode control interface operates at a very low frequency (**SysClock** divided by 256), allowing the initialization information to be kept in a low cost EPROM or system interface ASIC.

## 4.39 Boot-Time Modes

The boot-time serial mode stream is defined in Table 16. Bit 0 is presented to the processor as the first bit in the stream following **V<sub>CC</sub>OK** being asserted. Bit 255 is the last bit transferred.

**Table 16 Boot Time Mode Stream**

Mode bit	Description	Mode bit	Description
0 0	reserved (must be zero)	[17:16]	System configuration identifiers - software visible in <b>Config[21:20]</b>
[4:1]  0000	Write-back data rate 0: DDDD 1: DDxDDx 2: DDxxDDxx 3: DxDxDxDx 4: DDxxxDDxxx 5: DDxxxxDDxxxx 6: DxxDxxDxxDxx 7: DDxxxxxxDDxxxxxx 8: DxxxDxxxDxxxDxxx 9-15: reserved	[19:18]	Reserved: Must be zero
[7:5]  100	SysClock to Pclock Multiplier Mode bit 20 = 0 / Mode bit 20 = 1 0: Multiply by 2/x 1: Multiply by 3/x 2: Multiply by 4/x 3: Multiply by 5/2.5 4: Multiply by 6/x 5: Multiply by 7/3.5 6: Multiply by 8/x 7: Multiply by 9/4.5	20	Pclock to SysClock multipliers. 0: Integer multipliers (2,3,4,5,6,7,8,9) 1: Half integer multipliers (2.5,3.5,4.5)
8	Specifies byte ordering. Logically ORed with BigEndian input signal. 0: Little endian 1: Big endian	[23:21]	Reserved: Must be zero
[10:9]	Non-Block Write Control 00: R4000 compatible non-block writes 01: reserved 10: pipelined non-block writes 11: non-block write re-issue	24	JTLB Size. 0: 48 dual-entry 1: 64 dual-entry
11	Timer Interrupt Enable/Disable 0: Internal Timer Interrupt gated to <b>IP7</b> 1: External <b>INT5*</b> gated to <b>IP7</b>	25	On-chip secondary cache control. 0: Disable 1: Enable
12	Enable the external tertiary cache 0: Disable 1: Enable	26	Enable two outstanding reads with out-of-order return 0: Disable 1: Enable

Mode bit	Description	Mode bit	Description
[14:13]	Output driver strength - 100% = fastest 00: 67% strength 01: 50% strength 10: 100% strength 11: 83% strength	[255:27]	Reserved: Must be zero
15	External Tertiary cache RAM type: 0: Dual-cycle deselect (DCD) 1: Single-cycle deselect (SCD)		

## 5 Pin Descriptions

The following is a list of control, data, clock, tertiary cache, interrupt, and miscellaneous pins of the RM7000A.

**Table 17 System Interface**

Pin Name	Type	Description
<b>ExtRqst*</b>	Input	External request Signals that the external agent is submitting an external request.
<b>Release*</b>	Output	Release interface Signals that the processor is releasing the system interface to slave state
<b>RdRdy*</b>	Input	Read Ready Signals that an external agent can now accept a processor read.
<b>WrRdy*</b>	Input	Write Ready Signals that an external agent can now accept a processor write request.
<b>ValidIn*</b>	Input	Valid Input Signals that an external agent is now driving a valid address or data on the <b>SysAD</b> bus and a valid command or data identifier on the <b>SysCmd</b> bus.
<b>ValidOut*</b>	Output	Valid output Signals that the processor is now driving a valid address or data on the <b>SysAD</b> bus and a valid command or data identifier on the <b>SysCmd</b> bus.
<b>PRqst*</b>	Output	Processor Request When asserted this signal requests that control of the system interface be returned to the processor. This is enabled by Mode Bit 26.
<b>PAck*</b>	Input	Processor Acknowledge When asserted, in response to <b>PRqst*</b> , this signal indicates to the processor that it has been granted control of the system interface.
<b>RspSwap*</b>	Input	Response Swap <b>RspSwap*</b> is used by the external agent to signal the processor when it is about to return a memory reference out of order; i.e., of two outstanding memory references, the data for the second reference is being returned ahead of the data for the first reference. In order that the processor will have time to switch the address to the tertiary cache, this signal must be asserted a minimum of two cycles prior to the data itself being presented. Note that this signal works as a toggle; i.e., for each cycle that it is held asserted the order of return is reversed. By default, anytime the processor issues a second read it is assumed that the reads will be returned in order; i.e., no action is required if the reads are indeed returned in order. This is enabled by Mode Bit 26.

Pin Name	Type	Description
<b>RdType</b>	Output	Read Type During the address cycle of a read request, <b>RdType</b> indicates whether the read request is an instruction read or a data read.
<b>SysAD[63:0]</b>	Input/Output	System address/data bus A 64-bit address and data bus for communication between the processor and an external agent.
<b>SysADC[7:0]</b>	Input/Output	System address/data check bus An 8-bit bus containing parity check bits for the <b>SysAD</b> bus during data cycles.
<b>SysCmd[8:0]</b>	Input/Output	System command/data identifier bus A 9-bit bus for command and data identifier transmission between the processor and an external agent.
<b>SysCmdP</b>	Input/Output	System Command/Data Identifier Bus Parity For the RM7000A, unused on input and zero on output.

**Table 18 Clock/Control Interface**

Pin Name	Type	Description
<b>SysClock</b>	Input	System clock Master clock input used as the system interface reference clock. All output timings are relative to this input clock. Pipeline operation frequency is derived by multiplying this clock up by the factor selected during boot initialization
<b>VccP</b>	Input	<b>Vcc</b> for PLL Quiet <b>VccInt</b> for the internal phase locked loop. Must be connected to <b>VccInt</b> through a filter circuit.
<b>VssP</b>	Input	<b>Vss</b> for PLL Quiet <b>Vss</b> for the internal phase locked loop. Must be connected to <b>VssInt</b> through a filter circuit.

**Table 19 Tertiary Cache Interface**

Pin Name	Type	Description
<b>TcCLR*</b>	Output	Tertiary Cache Block Clear Requests that all valid bits be cleared in the Tag RAMs. Many RAMs may not support a block clear therefore the block clear capability is not required for the cache to operate.
<b>TcCWE[1:0]*</b>	Output	Tertiary Cache Write Enable Asserted to cause a write to the cache. Two identical signals are provided to balance the capacitive load relative to the remaining cache interface signals.
<b>TcDCE[1:0]*</b>	Output	Tertiary Cache Data RAM Chip Enable When asserted this signal causes the data RAMs to read out their contents. Two identical signals are provided to balance the capacitive load relative to the remaining cache interface signals

Pin Name	Type	Description
TcDOE*	Input	Tertiary Cache Data RAM Output Enable When asserted this signal causes the data RAMs to drive data onto their I/O pins. This signal is monitored by the processor to determine when to drive the data RAM write enable in a tertiary cache miss refill sequence.
TcLine[17:0]	Output	Tertiary Cache Line Index
TcMatch	Input	Tertiary Cache Tag Match This signal is asserted by the cache Tag RAMs when a match occurs between the value on its data inputs and the contents of the addressed location in the RAM.
TcTCE*	Output	Tertiary Cache Tag RAM Chip Enable When asserted this signal will cause either a probe or a write of the Tag RAMs depending on the state of the Tag RAMs write enable signal. This signal is monitored by the external agent and indicates to it that a tertiary cache access is occurring.
TcTDE*	Output	Tertiary Cache Tag RAM Data Enable When asserted this signal causes the value on the data inputs of the Tag RAM to be latched into the RAM. If a refill of the RAM is necessary, this latched value will be written into the Tag RAM array. Latching the Tag allows a shared address/data bus to be used without incurring a penalty to re-present the Tag during the refill sequence.
TcTOE*	Output	Tertiary Cache Tag RAM Output Enable When asserted this signal causes the Tag RAMs to drive data onto their I/O pins.
TcWord[1:0]	Input/Output	Tertiary Cache Double Word Index Driven by the processor on cache hits and by the external agent on cache miss refills.
TcValid	Input/Output	Tertiary Cache Valid This signal is driven by the processor as appropriate to make a cache line valid or invalid. On Tag read operations the Tag RAM will drive this signal to indicate the line state.

**Table 20 Interrupt Interface**

Pin Name	Type	Description
INT[9:0]*	Input	Interrupt Ten general processor interrupts, bit-wise ORed with bits 9:0 of the interrupt register.
NMI*	Input	Non-maskable interrupt Non-maskable interrupt, ORed with bit 15 of the interrupt register (bit 6 in R5000 compatibility mode).

**Table 21 JTAG Interface**

Pin Name	Type	Description
JTDI	Input	JTAG data in JTAG serial data in.

Pin Name	Type	Description
JTCK	Input	JTAG clock input JTAG serial clock input.
JTDO	Output	JTAG data out JTAG serial data out.
JTMS	Input	JTAG command JTAG command signal, signals that the incoming serial data is command data.

**Table 22 Initialization Interface**

Pin Name	Type	Description
BigEndian	Input	Big Endian / Little Endian Control Allows the system to change the processor addressing mode without rewriting the mode ROM.
VccOK	Input	<b>Vcc</b> is OK When asserted, this signal indicates to the RM7000A that the <b>VccInt</b> power supply has been above the recommended value for more than 100 milliseconds and will remain stable. The assertion of <b>VccOK</b> initiates the reading of the boot-time mode control serial stream.
ColdReset*	Input	Cold Reset This signal must be asserted for a power on reset or a cold reset. <b>ColdReset</b> must be de-asserted synchronously with <b>SysClock</b> .
Reset*	Input	Reset This signal must be asserted for any reset sequence. It may be asserted synchronously or asynchronously for a cold reset, or synchronously to initiate a warm reset. <b>Reset</b> must be de-asserted synchronously with <b>SysClock</b> .
ModeClock	Output	Boot Mode Clock Serial boot-mode data clock output at the system clock frequency divided by two hundred and fifty six.
ModeIn	Input	Boot Mode Data In Serial boot-mode data input.

## 6 Absolute Maximum Ratings<sup>1</sup>

Symbol	Rating	Limits	Unit
V <sub>TERM</sub>	Terminal Voltage with respect to V <sub>SS</sub>	-0.5 <sup>2</sup> to +3.9	V
T <sub>CASE</sub>	Operating Temperature		
	Commercial	0 to +85	°C
	Industrial	-40 to +85	°C
T <sub>STG</sub>	Storage Temperature	-55 to +125	°C
I <sub>IN</sub>	DC Input Current	±20	mA
I <sub>OUT</sub>	DC Output Current <sup>4</sup>	±20	mA

### Notes

1. Stresses greater than those listed under ABSOLUTE MAXIMUM RATINGS may cause permanent damage to the device. This is a stress rating only and functional operation of the device at these or any other conditions above those indicated in the operational sections of this specification is not implied. Exposure to absolute maximum rating conditions for extended periods may affect reliability.
2. V<sub>IN</sub> minimum = -2.0 V for pulse width less than 15 ns. V<sub>IN</sub> should not exceed 3.9 V.
3. When V<sub>IN</sub> < 0 V or V<sub>IN</sub> > V<sub>CCIO</sub>
4. Not more than one output should be shorted at a time. Duration of the short should not exceed 30 seconds.

## 7 Recommended Operating Conditions

Grade	CPU Speed	Temperature	V <sub>SS</sub>	V <sub>CCInt</sub>	V <sub>CCIO</sub>	V <sub>CCP</sub>
Commercial	300 - 350 MHz	0°C to +85°C (Case)	0 V	1.65V ± 50 mV	3.3 V ± 150 mV or 2.5 V ± 200 mV	1.65 V ± 50 mV
	400 MHz	0°C to +70°C (Case)	0 V	1.8V ± 50 mV	3.3 V ± 150 mV or 2.5 V ± 200 mV	1.8 V ± 50 mV
Industrial	350MHz	-40°C to +85°C (Case)	0 V	1.65 ± 50 mV	3.3 V ± 150 mV or 2.5 V ± 200 mV	1.65 V ± 50 mV

### Notes

1. **V<sub>CCIO</sub>** should not exceed **V<sub>CCInt</sub>** by greater than 2.0 V during the power-up sequence.
2. Applying a logic high state to any I/O pin before **V<sub>CCInt</sub>** becomes stable is not recommended.
3. As specified in IEEE 1149.1 (JTAG), the JTMS pin must be held high during reset to avoid entering JTAG test mode. Refer to the RM7000A Family Users Manual, Appendix E.
4. **V<sub>CCP</sub>** must be connected to **V<sub>CCInt</sub>** through a passive filter circuit. See RM7000 Family User's Manual for recommended circuit.

## 8 DC Electrical Characteristics

Table 23 ( $V_{CCIO} = 3.15\text{ V} - 3.45\text{ V}$ )

Parameter	Minimum	Maximum	Conditions
$V_{OL}$		0.2 V	$ I_{OUT}  = 100\ \mu\text{A}$
$V_{OH}$	$V_{CCIO} - 0.2\text{ V}$		
$V_{OL}$		0.4 V	$ I_{OUT}  = 2\text{ mA}$
$V_{OH}$	2.4 V		
$V_{IL}$	-0.3 V	0.8 V	
$V_{IH}$	2.0 V	$V_{CCIO} + 0.3\text{ V}$	
$I_{IN}$		$\pm 15\ \mu\text{A}$ $\pm 15\ \mu\text{A}$	$V_{IN} = 0$ $V_{IN} = V_{CCIO}$

Table 24 ( $V_{CCIO} = 2.3\text{ V} - 2.7\text{ V}$ )

Parameter	Minimum	Maximum	Conditions
$V_{OL}$		0.2 V	$ I_{OUT}  = 100\ \mu\text{A}$
$V_{OH}$	2.1 V		
$V_{OL}$		0.4 V	$ I_{OUT}  = 1\text{ mA}$
$V_{OH}$	2.0		
$V_{OL}$		0.7 V	$ I_{OUT}  = 2\text{ mA}$
$V_{OH}$	1.7		
$V_{IL}$	-0.3 V	0.7 V	
$V_{IH}$	1.7 V	$V_{CCIO} + 0.3\text{ V}$	
$I_{IN}$		$\pm 15\ \mu\text{A}$ $\pm 15\ \mu\text{A}$	$V_{IN} = 0$ $V_{IN} = V_{CCIO}$

## 9 Power Consumption

Parameter		Conditions	CPU Speed		
			300 MHz	350 MHz	400 MHz
			Max <sup>1</sup>	Max <sup>1</sup>	Max <sup>1</sup>
V <sub>ccInt</sub> Power (mWatts)	standby		865	865	925
	active	Maximum with no FPU operation <sup>2</sup>	2350	2750	3550
		Maximum worst case instruction mix	2500	3000	4000

### Notes

1. Worst case supply voltage (maximum V<sub>ccInt</sub>) with worst case temperature (maximum TCase).
2. Dhrystone 2.1 instruction mix.
3. I/O supply power is application dependant, but typically <20% of V<sub>ccInt</sub>.

## 10 AC Electrical Characteristics

### 10.1 Capacitive Load Deration

Parameter	Symbol	Min	Max	Units
Load Derate	C <sub>LD</sub>		2	ns/25pF

### 10.2 Clock Parameters

Parameter	Symbol	Test Conditions	CPU Speed						Units
			300 MHz		350 MHz		400 MHz		
			Min	Max	Min	Max	Min	Max	
<b>SysClock High</b>	t <sub>SCHigh</sub>	Transition ≤ 5ns	3		3		3		ns
<b>SysClock Low</b>	t <sub>SCLow</sub>	Transition ≤ 5ns	3		3		3		ns
<b>SysClock Frequency</b>			33.3	125	33.3	125	33.1 3	125	MHz
<b>SysClock Period</b>	t <sub>SCP</sub>		8	30	8	30	8	30	ns
<b>Clock Jitter for SysClock</b>	t <sub>JitterIn</sub>			±150		±150		±150	ps
<b>SysClock Rise Time</b>	t <sub>SCRise</sub>			2		2		2	ns
<b>SysClock Fall Time</b>	t <sub>SCFall</sub>			2		2		2	ns
<b>ModeClock Period</b>	t <sub>ModeCKP</sub>			256		256		256	t <sub>SCP</sub>
<b>JTAG Clock Period</b>	t <sub>JTAGCKP</sub>		4		4		4		t <sub>SCP</sub>

**Note:**

1. Operation of the RM7000A is only guaranteed with the Phase Lock Loop Enabled.

### 10.3 System Interface Parameters

Parameter <sup>1</sup>	Symbol	Test Conditions	CPU Speed						Units
			300 MHz		350 MHz		400 MHz		
			Min	Max	Min	Max	Min	Max	
Data Output <sup>2,3</sup>	t <sub>DO</sub>	mode14..13 = 10 <sup>5,6</sup> (fastest)	1.0	4.5	1.0	4.5	1.0	4.5	ns
		mode14..13 = 01 <sup>5,6</sup> (slowest)	1.0	5.5	1.0	5.5	1.0	5.5	ns
Data Setup <sup>4</sup>	t <sub>DS</sub> <sup>6</sup>	t <sub>rise</sub> = see above table	2.5		2.5		2.5		ns
Data Hold <sup>4</sup>	t <sub>DH</sub>	t <sub>fall</sub> = see above table	1.0		1.0		1.0		ns

**Notes**

1. Timings are measured from 0.425 x V<sub>CCIO</sub> of clock to 0.425 x V<sub>CCIO</sub> of signal for 3.3 V I/O. Timings are measured from 0.48 x V<sub>CCIO</sub> of clock to 0.48 x V<sub>CCIO</sub> of signal for 2.5 V I/O.
2. Capacitive load for all maximum output timings is 50 pF. Minimum output timings are for theoretical no load conditions - untested.
3. Data Output timing applies to all signal pins whether tristate I/O or output only.
4. Setup and Hold parameters apply to all signal pins whether tristate I/O or input only.
5. Only mode 14:13 = 10 is tested and guaranteed.
6. Data shown is for 3.3 V I/O. For 2.5 V I/O derate all times by 0.5 nS.

### 10.4 Boot-Time Interface Parameters

Parameter	Symbol	Min	Max	Units
Mode Data Setup	t <sub>DS</sub>	4		SysClock cycles
Mode Data Hold	t <sub>DH</sub>	0		SysClock cycles

## 11 Timing Diagrams

### 11.1 Clock Timing

Figure 12 Clock Timing

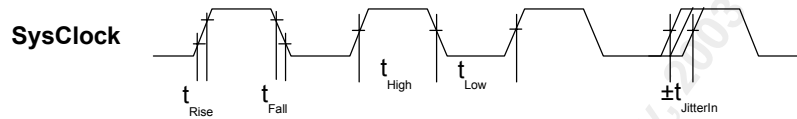

### 11.2 System Interface Timing

(SysAD, SysCmd, ValidIn\*, ValidOut\*, etc.)

Figure 13 Input Timing

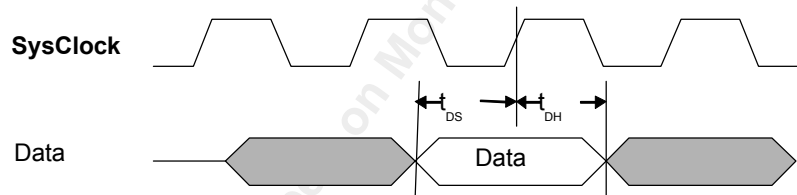
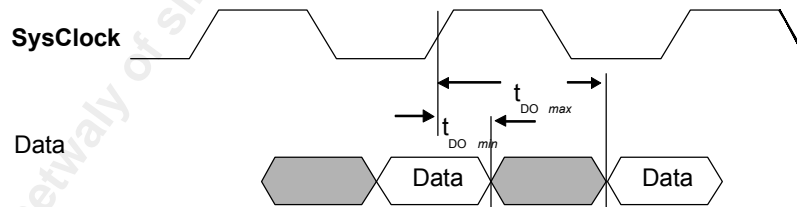
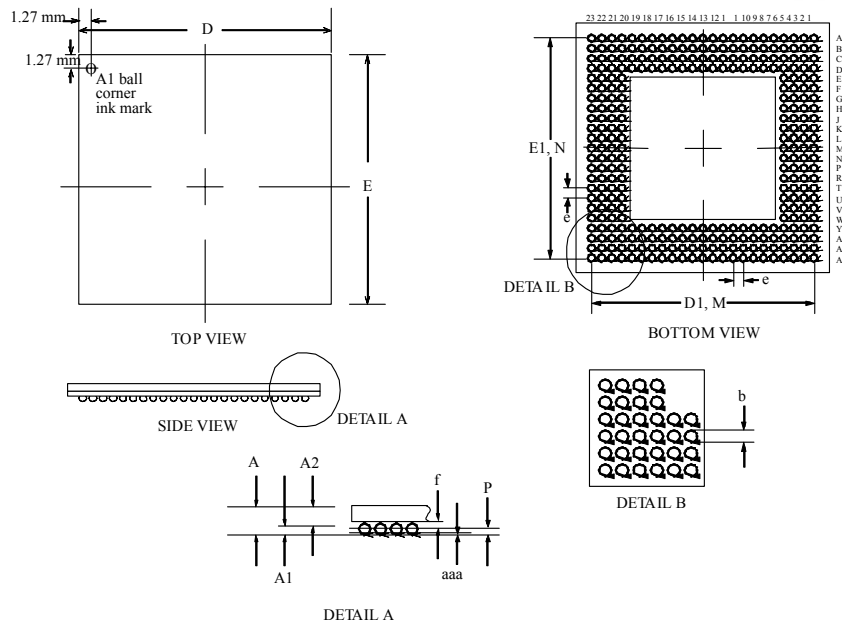

Figure 14 Output Timing



## 12 Packaging Information

Figure 15 304-TBGA Drawing



Body Size: 31.0 x 31.0 mm Package

Symbol	Min	Nominal	Max	Note
A	1.45	1.55	1.65	Overall Thickness
A1	0.60	0.65	0.70	Ball Height
A2	0.85	0.90	0.95	Body Thickness
D, E	30.80	31.00	31.20	Body Size
D1, E1	27.94			Ball Footprint
M,N	23 x 23			Ball Matrix
M1	4			Number of Rows Deep
b	0.65	0.75	0.85	Ball Diameter
e	1.27			Ball Pitch
aaa	0.15			Coplanarity
bbb	0.15			Parallel
f	0.30	0.35	0.40	Seating Plan Clearance
P	0.25			Encapsulation Height
Theta JC	0.3			Deg. C/Watt
Theta JA	13			Deg. C/Watt @ 0 cfm airflow.

**Note:**

1. All dimensions in millimeters unless otherwise indicated.

## 13 RM7000A Pinout

Pin	Function	Pin	Function	Pin	Function	Pin	Function
A1	V <sub>cc</sub> I/O	A2	V <sub>ss</sub> I/O	A3	V <sub>ss</sub> I/O	A4	TcLine11
A5	Do not connect	A6	V <sub>ss</sub> I/O	A7	Do Not Connect	A8	V <sub>ss</sub> I/O
A9	SysAD32	A10	SysADC1	A11	Do Not Connect	A12	V <sub>ss</sub> I/O
A13	V <sub>cc</sub> Int	A14	V <sub>cc</sub> Int	A15	SysAD63	A16	V <sub>ss</sub> I/O
A17	SysAD61	A18	V <sub>ss</sub> I/O	A19	Do Not Connect	A20	TcLine4
A21	V <sub>ss</sub> I/O	A22	V <sub>ss</sub> I/O	A23	V <sub>cc</sub> I/O	B1	V <sub>ss</sub> Int
B2	V <sub>cc</sub> I/O	B3	V <sub>ss</sub> Int	B4	V <sub>ss</sub> I/O	B5	TcLine10
B6	SysAD35	B7	SysAD34	B8	V <sub>cc</sub> Int	B9	SysAD33
B10	SysADC5	B11	SysADC0	B12	Do Not Connect	B13	SysADC7
B14	SysADC6	B15	Do Not Connect	B16	SysAD30	B17	SysAD29
B18	SysAD28	B19	TcLine5	B20	V <sub>ss</sub> I/O	B21	V <sub>ss</sub> Int
B22	V <sub>cc</sub> I/O	B23	V <sub>ss</sub> I/O	C1	V <sub>ss</sub> I/O	C2	V <sub>ss</sub> Int
C3	V <sub>cc</sub> I/O	C4	V <sub>cc</sub> I/O	C5	Do Not Connect	C6	TcLine9
C7	SysAD3	C8	SysAD2	C9	V <sub>cc</sub> Int	C10	SysAD0
C11	SysADC4	C12	V <sub>cc</sub> Int	C13	SysADC3	C14	SysADC2
C15	SysAD62	C16	V <sub>cc</sub> Int	C17	SysAD60	C18	TcLine6
C19	Do Not Connect	C20	V <sub>cc</sub> I/O	C21	V <sub>cc</sub> I/O	C22	V <sub>ss</sub> Int
C23	V <sub>ss</sub> I/O	D1	TcLine13	D2	V <sub>ss</sub> I/O	D3	V <sub>cc</sub> I/O
D4	V <sub>cc</sub> I/O	D5	V <sub>cc</sub> I/O	D6	V <sub>cc</sub> I/O	D7	TcLine8
D8	V <sub>cc</sub> Int	D9	V <sub>cc</sub> I/O	D10	SysAD1	D11	V <sub>cc</sub> Int
D12	V <sub>cc</sub> I/O	D13	V <sub>cc</sub> Int	D14	SysAD31	D15	V <sub>cc</sub> I/O
D16	V <sub>cc</sub> Int	D17	TcLine7	D18	V <sub>cc</sub> I/O	D19	V <sub>cc</sub> I/O
D20	V <sub>cc</sub> I/O	D21	V <sub>cc</sub> I/O	D22	V <sub>ss</sub> I/O	D23	Do Not Connect
E1	V <sub>cc</sub> Int	E2	TcLine14	E3	TcLine12	E4	V <sub>cc</sub> I/O
E20	V <sub>cc</sub> I/O	E21	Do Not Connect	E22	Do Not Connect	E23	TcLine1
F1	V <sub>ss</sub> I/O	F2	TcLine16	F3	TcLine15	F4	V <sub>cc</sub> I/O
F20	V <sub>cc</sub> I/O	F21	TcLine3	F22	TcLine0	F23	V <sub>ss</sub> I/O
G1	SysAD36	G2	SysAD4	G3	TcLine17	G4	V <sub>cc</sub> Int
G20	TcLine2	G21	V <sub>cc</sub> Int	G22	SysAD59	G23	SysAD58
H1	V <sub>ss</sub> I/O	H2	SysAD37	H3	SysAD5	H4	Do Not Connect
H20	V <sub>cc</sub> Int	H21	SysAD27	H22	SysAD26	H23	V <sub>ss</sub> I/O
J1	SysAD7	J2	SysAD6	J3	V <sub>cc</sub> Int	J4	V <sub>cc</sub> I/O
J20	V <sub>cc</sub> I/O	J21	V <sub>cc</sub> Int	J22	SysAD57	J23	SysAD56
K1	SysAD40	K2	SysAD8	K3	SysAD39	K4	SysAD38
K20	SysAD25	K21	SysAD24	K22	SysAD55	K23	SysAD23
L1	SysAD10	L2	SysAD41	L3	SysAD9	L4	V <sub>cc</sub> Int
L20	V <sub>cc</sub> Int	L21	SysAD54	L22	SysAD22	L23	SysAD53
M1	V <sub>ss</sub> I/O	M2	SysAD11	M3	SysAD42	M4	V <sub>cc</sub> I/O

Pin	Function	Pin	Function	Pin	Function	Pin	Function
M20	V <sub>cc</sub> O	M21	SysAD52	M22	SysAD21	M23	V <sub>ss</sub> O
N1	SysAD43	N2	V <sub>cc</sub> Int	N3	SysAD12	N4	SysAD44
N20	SysAD19	N21	SysAD51	N22	V <sub>cc</sub> Int	N23	SysAD20
P1	SysAD13	P2	SysAD45	P3	SysAD14	P4	V <sub>cc</sub> Int
P20	V <sub>cc</sub> Int	P21	SysAD49	P22	SysAD18	P23	SysAD50
R1	SysAD46	R2	SysAD15	R3	SysAD47	R4	V <sub>cc</sub> O
R20	V <sub>cc</sub> O	R21	SysAD16	R22	SysAD48	R23	SysAD17
T1	V <sub>ss</sub> O	T2	RspSwap*	T3	PRqst*	T4	V <sub>cc</sub> Int
T20	ExtRqst*	T21	V <sub>cc</sub> OK	T22	BigEndian	T23	V <sub>ss</sub> O
U1	PAck*	U2	V <sub>cc</sub> Int	U3	ModeClock	U4	JTCK
U20	V <sub>cc</sub> Int	U21	NMI*	U22	Reset*	U23	ColdReset*
V1	V <sub>ss</sub> O	V2	JTDO	V3	JTMS	V4	V <sub>cc</sub> O
V20	V <sub>cc</sub> O	V21	INT9*	V22	V <sub>cc</sub> Int	V23	V <sub>ss</sub> O
W1	JTDI	W2	V <sub>cc</sub> O	W3	Do Not Connect	W4	V <sub>cc</sub> O
W20	V <sub>cc</sub> O	W21	INT6*	W22	INT8*	W23	V <sub>cc</sub> Int
Y1	Do Not Connect	Y2	V <sub>ss</sub> O	Y3	V <sub>cc</sub> O	Y4	V <sub>cc</sub> O
Y5	V <sub>cc</sub> O	Y6	V <sub>cc</sub> O	Y7	RdRdy*	Y8	Release*
Y9	V <sub>cc</sub> O	Y10	TcWord0	Y11	V <sub>cc</sub> Int	Y12	V <sub>cc</sub> O
Y13	SysCmd5	Y14	V <sub>cc</sub> Int	Y15	V <sub>cc</sub> O	Y16	V <sub>cc</sub> Int
Y17	INT2*	Y18	V <sub>cc</sub> O	Y19	V <sub>cc</sub> O	Y20	V <sub>cc</sub> O
Y21	V <sub>cc</sub> O	Y22	V <sub>ss</sub> O	Y23	INT7*	AA1	V <sub>ss</sub> O
AA2	V <sub>ss</sub> Int	AA3	V <sub>cc</sub> O	AA4	V <sub>cc</sub> O	AA5	Do Not Connect
AA6	TcMatch	AA7	ValidOut*	AA8	SysClock	AA9	V <sub>cc</sub> Int
AA10	Do Not Connect	AA11	Do Not Connect	AA12	SysCmd0	AA13	SysCmd4
AA14	SysCmd8	AA15	TcTCE*	AA16	TcValid	AA17	V <sub>cc</sub> Int
AA18	INT3*	AA19	Do Not Connect	AA20	V <sub>cc</sub> O	AA21	V <sub>cc</sub> O
AA22	V <sub>ss</sub> Int	AA23	V <sub>ss</sub> O	AB1	V <sub>ss</sub> O	AB2	V <sub>cc</sub> O
AB3	V <sub>ss</sub> Int	AB4	V <sub>ss</sub> O	AB5	Modeln	AB6	Validin*
AB7	V <sub>cc</sub> P	AB8	V <sub>cc</sub> Int	AB9	V <sub>cc</sub> Int	AB10	TcCWE0*
AB11	TcDCE0*	AB12	SysCmd1	AB13	SysCmd3	AB14	SysCmd7
AB15	TcClr*	AB16	TcTDE*	AB17	TcDOE*	AB18	INT0*
AB19	INT4*	AB20	V <sub>ss</sub> O	AB21	V <sub>ss</sub> Int	AB22	V <sub>cc</sub> O
AB23	V <sub>ss</sub> Int	AC1	V <sub>cc</sub> O	AC2	V <sub>ss</sub> Int	AC3	V <sub>ss</sub> O
AC4	RdType	AC5	WrRdy*	AC6	V <sub>ss</sub> O	AC7	V <sub>ss</sub> P
AC8	V <sub>ss</sub> O	AC9	TcWord1	AC10	TcCWE1*	AC11	TcDCE1*
AC12	V <sub>ss</sub> O	AC13	SysCmd2	AC14	SysCmd6	AC15	SysCmdP
AC16	V <sub>ss</sub> O	AC17	TcTOE*	AC18	V <sub>ss</sub> O	AC19	INT1*
AC20	INT5*	AC21	V <sub>ss</sub> O	AC22	V <sub>ss</sub> O	AC23	V <sub>cc</sub> O

## 14 Ordering Information

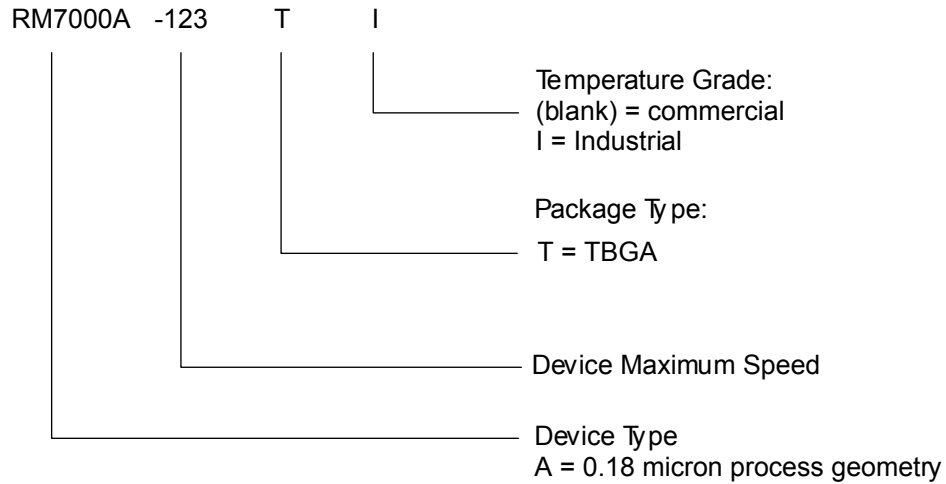

### Valid Combinations

RM7000A-300T  
RM7000A-350T  
RM7000A-400T  
RM7000A-350TI

## Notes

Downloaded by ahmed metwaly of siliconexpert on Monday, 06 January, 2003 03:28:22 AM

Find price and stock options from leading distributors for RM7000A-350R on Findchips.com:

<https://findchips.com/search/RM7000A-350R>

Find CAD models and details for this part:

<https://findchips.com/detail/rm7000a-350r/Microsemi-Storage-OTN-and-Networking-Solutions>