

Bus Interfaces

There are three basic buses supported by IRIS systems - VME, GIO and EISA.

Most of the early systems supported VME where add-in cards could be either 6U or 9U sized. 6U sized cards were added using an extender board. Although the card slots for Twin Tower, Single Tower, Deskside and Rack systems are all 9U sized, not all of these slots are configured as VME slots. This is covered in more detail in the section on backplanes starting on page 140. The Personal IRIS supported one 6U VME card.

Starting with the Indigo, the GIO (Graphics I/O) bus became the bus for expansion. There are three variations of the GIO bus. Two are physically identical, differing only in the bus protocol (GIO32 and GIO32-bis). The board size for these two is roughly 3" by 6". The third, GIO64, is a much larger board and, as can be noted from the name, is 64 bits wide instead of 32 bits wide. Boards for this bus are the same size as EISA boards since both GIO64 boards and EISA boards live in the same backplane. A more detailed description of the GIO bus protocols, electrical requirements and pinouts is documented in the GIO Bus Specification. This document is available (under non-disclosure) from the Developers Program.

The EISA bus is the industry standard bus as used by the PC community. It's data paths are 32 bits wide. Currently the Indigo² is the only chassis that supports the EISA bus.

A simple comparison of bus bandwidths is in the table below:

Bus	Maximum Bandwidth
VME (32 bit)	26 - 28 MB/sec
GIO32 or GIO32-bis	100 MB/sec
GIO64 (Indigo ²)	200 MB./sec
EISA (Indigo ²)	18 - 21 MB/sec

Table 54 Bus Bandwidths

The table below shows which busses are supported by IRIS chassis. Numbers in the table indicate how many boards or slots are available but not necessarily the total number of slots contained in the chassis. For VME systems many of the 9U slots are used by CPU or graphics cards that do not have a VME pinout (or in some cases VME-like connectors).

Chassis	Model/ Graphics	32 Bit VME (9U)	32 Bit VME (6U)	64 Bit VME (9U) ⁶	GIO32	GIO32 -bis	GIO64	EISA
Twin Tower 12 Slot	All	8 ¹						
Twin Tower 15 Slot	All	4						
Diehard	All	4						
Predator	GTX, VGX, VGXT	6						
	Server	6 + 5 ²						
	SkyWriter	4						
Diehard2	Crimson	4						
Eveready	Onyx - VTX, RE ²			3				
	Challenge L Server			5				
Terminator	Onyx - VTX, RE ²			3 + 20 or 3 + 6 ³				
	Challenge XL Server			5 + 20 ⁴				
Personal IRIS	All		1					
Indigo	R3000				2			
	R4000					2		
Indigo ²	All						2 ⁵	4 ⁵
Indy	All					2		

Table 55 Bus Interfaces on IRIS Systems

1. These slots are also used by the CPU, disk controllers, ethernet and any memory boards.
2. Predator Servers have 2 VME busses. Bus A has 6 slots, Bus B has 5 slots.
3. The Onyx system may add either an expansion VME card cage providing 20 additional VME64 slots, or a graphics expansion card cage providing 6 additional VME64 slots (as well as additional graphics slots).
4. The Challenge XL system may add an expansion VME card cage providing 20 additional VME64 slots.
5. GIO64 and EISA boards in an Indigo² share 4 *physical* slots.
6. VME 64 slots on Eveready and Terminator chassis do not support VSB pins.

VME32 (9U)

The VME32 slots can accept either 9U or 6U sized boards. 6U boards may be either installed directly into the backplane in P1 and P2 connectors, or can be installed on an extender.

Note that VME cards for SGI systems do not require front panels. Front panels are normally required for EMI sealing and connector mounting. Since all the system using VME (with the exception of the Personal IRIS) rely on the I/O Panel for EMI sealing, front panels are necessary. In fact, installing a 6U card with a front panel directly into the backplane will almost certainly cause the front panel to short out against any card in the slot to the right of the board.

Systems supporting VME32 have backplane pins that allow VSB connections to be made. VME64 slots do not.

Board Outline

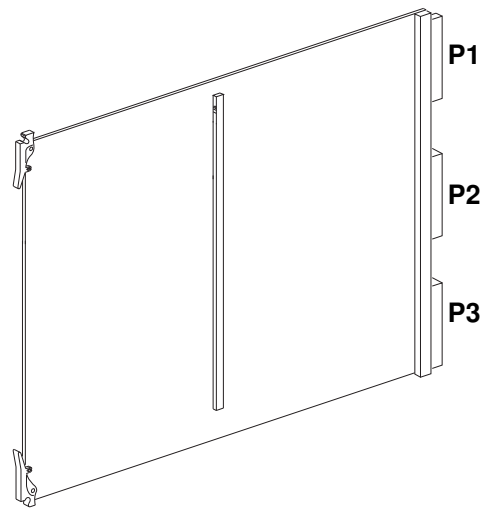

Figure 42 9U VME Board

Backplane Jumpering

VME backplanes require the four Bus Grant In & Out lines and the Interrupt Acknowledge line to be passed from one card slot to the next. On the early IRIS backplanes (specifically the 12 slot Twin Tower chassis) required jumpers to be put in place for these 5 signals for every empty slot to allow proper operation of the system. The 5 jumpers must be removed for every slot where a board is installed.

Starting with the 15 Slot Twin Tower chassis, the backplanes were designed so that, in most cases, jumpers were not required. If VME cards were installed starting in the leftmost VME slot and with additional cards going into the next VME slot to the right, no jumpers would be required. If, however, an empty slot was left between two slots, or if the first VME card was not in the leftmost VME slot, jumpers would be required for each empty slot.

Power Budget

The table below shows the maximum current available for each of the supply voltages on the VME connectors.

Voltage	Max Current	Power
+ 5 V	5 A	25 W
+12 V	0.1 A	1.2 W
- 12 V	0.1 A	1.2 W
Total Power Budget (per slot)		28 W

Table 56 VME32 Power Budget (Twin & Single Towers)

An exception to this is that some DieHard chassis have one slot that complies with “Sun VME” power requirements. It’s power allocation is shown below:

Voltage	Max Current	Power
+ 5 V	7 A	35 W
+12 V	0.1 A	1.2 W
- 12 V	0.1 A	1.2 W
-5.2 V	0.1 A	0.52 W
Total Power Budget (per slot)		41 W

Table 57 VME32 Power Budget (Diehard & Diehard2)

Pinout

Pin	P1			P2			P3		
	A	B	C	A	B	C	A	B	C
1	D00	BBSY*	D08		+5V		+5V		GND
2	D01	BCLR*	D09		GND		+5V		GND
3	D02	ACFAIL	D10		RES.		+5V		GND
4	D03	BG0IN*	D11		A24		+5V		GND
5	D04	BG0OUT*	D12		A25		+5V		GND
6	D05	BG1IN*	D13		A26		+5V		GND
7	D06	BG1OUT*	D14		A27		+5V		GND
8	D07	BG2IN*	D15		A28		+5V		GND
9	GND	BG2OUT*	GND		A29		+5V		GND
10	SYSCLK	BG3IN*	SYSFAIL*		A30		+5V		GND
11	GND	BG3OUT*	BERR*	U	A31	U	+5V	U	GND
12	DS1*	BR0*	SYSRESET*	S	GND	S	+5V	S	GND
13	DS0*	BR1*	LWORD*	E	+5V	E	+5V	E	GND
14	WRITE*	BR2*	AM5	R	D16	R	+5V	R	GND
15	GND	BR3*	A23		D17		+5V		GND
16	DTACK	AM0	A22	D	D18	D	+5V	D	GND
17	GND	AM1	A21	E	D19	E	+5V	E	GND
18	AS*	AM2	A20	F	D20	F	+5V	F	GND
19	GND	AM3	A19		D21		+5V		GND
20	IACK*	GND	A18	I	D22	I	+5V	I	GND
21	IACKIN*	SERCLK	A17	N	D23	N	+5V	N	GND
22	IACKOUT*	SERDAT*	A16	E	GND	E	+5V	E	GND
23	AM4	GND	A15	D	D24	D	+5V	D	GND
24	A07	IRQ7*	A14		D25		+5V		GND
25	A06	IRQ6*	A13		D26		+5V		GND
26	A05	IRQ5*	A12		D27		+12V		+12V
27	A04	IRQ4*	A11		D28		+12V		+12V
28	A03	IRQ3*	A10		D29		-12V		-12V
29	A02	IRQ2*	A09		D30		-12V		-12V
30	A01	IRQ1*	A08		D31		Vee		Vee
31	-12V	+5STDBY	+12V		GND		Vee		Vee
32	+5V	+5V	+5V		+5V		Vee		Vee

Table 58 VME32 Pinout

VME32 (6U)

The Personal IRIS has one 6U sized VME slot. It's pinout is identical to the P1 and P2 pinouts described in Table 58, "VME32 Pinout", on page 128.

Access to the user defined pins of P2 is available in one of two different means depending on the Personal IRIS model. In the 4D/20 or 4D/25 access to the P2 user defined pins is only available inside the E-Module. A Eurocard style connector (AMP part number XXXXXXXX) connects to the back of the VME slot P2 connector. This connection can, if necessary, be brought out of the E-Module via a blank panel just above the audio jacks on the I/O panel area.

On the 4D/30 and 4D/35, access to the user defined P2 pins are available via a high density 100 pin connector on the I/O panel area of the E-Module. This interface is documented in the next section.

For EMI purposes, VME boards must have an I/O Panel that provides a seal against the E-Module. The opening for the VME slot requires a panel different than the panels found on most "standard" VME boards (which, by their design do not provide any EMI sealing). A "standard" VME board will install into the single slot without any problem - but it will not provide any EMI sealing.

Board Outline

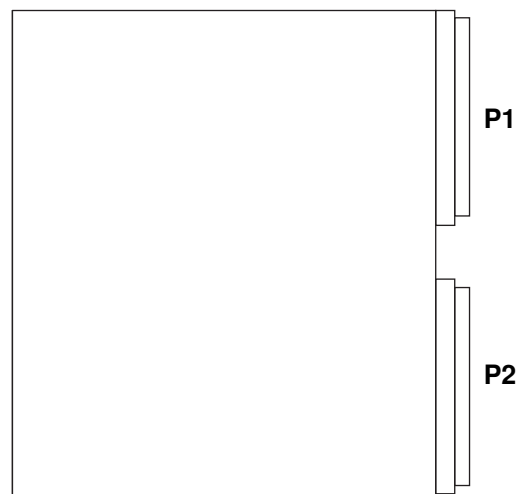

Figure 43 6U VME Board

Backplane Jumpering

Since there is only one slot in the Personal IRIS, there are no backplane jumpering considerations.

Power Budget

The table below shows the maximum current available for each of the supply voltages on the VME connectors.

Voltage	Max Current	Power
+ 5 V	5 A	25 W
+12 V	0.1 A	1.2 W
- 12 V	0.1 A	1.2 W
Total Power Budget (per slot)		28 W

Table 59 VME32 Power Budget (Twin & Single Towers)

VME P2 Expansion

Access to the user defined pins of the VME P2 connector is possible on most all of the IRIS systems that support VME. In the case of the Twin Tower, Diehard, Diehard2 and Eveready this is done by connecting to connector pins on the back of the backplane.

For the Personal IRIS two methods are used to connect to these pins. One, on the 4D/20 and 4D/25 is via a connection on the back of the P2 connector inside the E-Module. Using a Eurocard style connector will accomplish this.

On the 4D/30 and 4D/35 the user defined pins, as well as some power and ground connections are brought out to a high density 100 pin connector in the I/O Panel area of the E-Module. This section documents that interface.

Connector Drawing

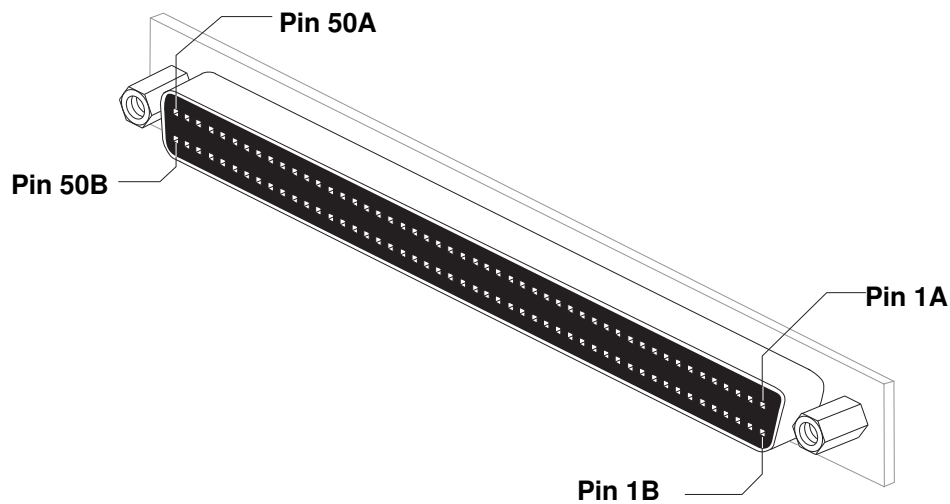

Figure 44 VME P2 Expansion Connector

Power Availability

The maximum current available at this connector for the voltages supplied is shown in the table below.

Voltage	Current	Power
+ 5 V	2.0 A	10 W
+12 V	2.0 A	24 W
- 12 V	2.0 A	24 W
Total Power Budget (per slot)		58 W

Table 60 VME P2 Expansion Power Budget

Pinout

Pin	Signal	Pin	Signal	Pin	Signal	Pin	Signal
1A	GND	1B	GND	26A	P2, A17	26B	P2, C17
2A	+5V	2B	+5V	27A	P2, A18	27B	P2, C18
3A	GND	3B	GND	28A	P2, A19	28B	P2, C19
4A	+5V	4B	+5V	29A	P2, A20	29B	P2, C20
5A	GND	5B	GND	30A	P2, A21	30B	P2, C21
6A	-12V	6B	-12V	31A	P2, A22	31B	P2, C22
7A	GND	7B	GND	32A	P2, A 23	32B	P2, C23
8A	-12V	8B	-12V	33A	P2, A 24	33B	P2, C24
9A	GND	9B	GND	34A	P2, A25	34B	P2, C25
10A	P2, A1	10B	P2, C1	35A	P2, A26	35B	P2, C26
11A	P2, A2	11B	P2, C2	36A	P2, A27	36B	P2, C27
12A	P2, A3	12B	P2, C3	37A	P2, A28	37B	P2, C28
13A	P2, A4	13B	P2, C4	38A	P2, A29	38B	P2, C29
14A	P2, A5	14B	P2, C5	39A	P2, A30	39B	P2, C30
15A	P2, A6	15B	P2, C6	40A	P2, A31	40B	P2, C31
16A	P2, A7	16B	P2, C7	41A	P2, A32	41B	P2, C32
17A	P2, A8	17B	P2, C8	42A	GND	42B	GND
18A	P2, A9	18B	P2, C9	43A	+5V	43B	+5V
19A	P2, A10	19B	P2, C10	44A	+5V	44B	+5V
20A	P2, A11	20B	P2, C11	45A	GND	45B	GND
21A	P2, A12	21B	P2, C12	46A	-12V	46B	-12V
22A	P2, A13	22B	P2, C13	47A	GND	47B	GND
23A	P2, A14	23B	P2, C14	48A	+12V	48B	+12V
24A	P2, A15	24B	P2, C15	49A	GND	49B	GND
25A	P2, A16	25B	P2, C16	50A	+12V	50B	+12V

Table 61 VME P2 Expansion Pinout (Personal IRIS)

VME64 (9U)

The VME64 slots available in the Onyx and Challenge systems are the same physical size as those found in other IRIS systems. However, they have additional data signals making the data bus 64 bits wide. These slots do not support VSB connections.

Board Outline

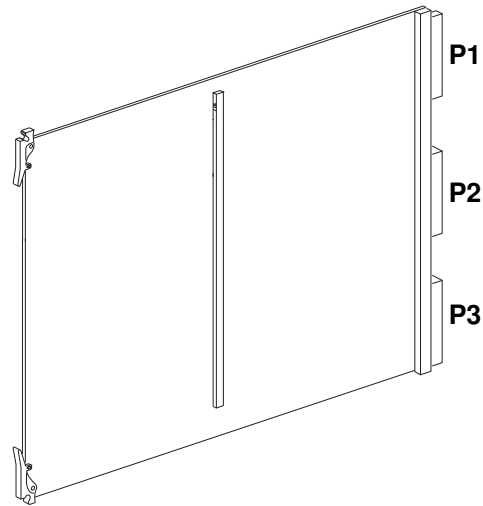

Figure 45 9U VME64 Board

Backplane Jumpering

Jumpering the Bus Grant In & Out and Interrupt Acknowledge signals follow the same rules as the VME slots in previous Single Tower and Rack systems.

In most cases, jumpers are not required. If VME cards are installed starting in the leftmost VME slot and with additional cards going into the next VME slot to the right, no jumpers would be required. If, however, an empty slot is left between two slots, or if the first VME card is not in the leftmost VME slot, jumpers are required for each empty slot.

Power Budget

Voltage	Current	Power
+ 5 V	8A	40 W
+12 V	0.2 A	2.4 W
- 12 V	0.2 A	2.4 W
-5.2 V	0.2 A	1 W
Total Power Budget (per slot)		48 W

Table 62 VME64 Power Budget (Onyx and Challenge)

Pinout

Pin	P1			P2			P3		
	A	B	C	A	B	C	A	B	C
1	D00	BBSY*	D08		+5V		+5V		GND
2	D01	BCLR*	D09		GND		+5V		GND
3	D02	ACFAIL	D10		RES.		+5V		GND
4	D03	BG0IN*	D11		A24		+5V		GND
5	D04	BG0OUT*	D12		A25		+5V		GND
6	D05	BG1IN*	D13		A26		+5V		GND
7	D06	BG1OUT*	D14		A27		+5V		GND
8	D07	BG2IN*	D15		A28		+5V		GND
9	GND	BG2OUT*	GND		A29		+5V		GND
10	SYSCLK	BG3IN*	SYSFAIL*		A30		+5V		GND
11	GND	BG3OUT*	BERR*	U	A31	U	+5V	U	GND
12	DS1*	BR0*	SYSRESET*	S	GND	S	+5V	S	GND
13	DS0*	BR1*	LWORD*	E	+5V	E	+5V	E	GND
14	WRITE*	BR2*	AM5	R	D16	R	+5V	R	GND
15	GND	BR3*	A23		D17		+5V		GND
16	DTACK*	AM0	A22	D	D18	D	+5V	D	GND
17	GND	AM1	A21	E	D19	E	+5V	E	GND
18	AS*	AM2	A20	F	D20	F	+5V	F	GND
19	GND	AM3	A19	I	D21	I	+5V	I	GND
20	IACK*	GND	A18	N	D22	N	+5V	N	GND
21	IACKIN*	SERCLK	A17	E	D23	E	+5V	E	GND
22	IACKOUT*	SERDAT*	A16	D	GND	D	+5V	D	GND
23	AM4	GND	A15		D24		+5V		GND
24	A07	IRQ7*	A14		D25		+5V		GND
25	A06	IRQ6*	A13		D26		+5V		GND
26	A05	IRQ5*	A12		D27		+12V		+12V
27	A04	IRQ4*	A11		D28		+12V		+12V
28	A03	IRQ3*	A10		D29		-12V		-12V
29	A02	IRQ2*	A09		D30		-12V		-12V
30	A01	IRQ1*	A08		D31		Vee		Vee
31	-12V	+5STDBY	+12V		GND		Vee		Vee
32	+5V	+5V	+5V		+5V		Vee		Vee

Table 63 VME64 Pinout

GIO32/32-bis

The GIO32 or GIO32-bis buses are used in the Indigo and Indy products (see Table 55, on page 125 for specific details). Since the two GIO slots on these systems are both attached to the motherboard, or CPU board, it is possible to design a board that takes up both slot spaces.

GIO slots have a fixed address space. Slot 0 always occupies a particular address space while Slot 1 occupies a different address space. This is unlike VME where settings on the board itself determine the address the board responds to.

The I/O panels for Indigo and Indy are different. There is more space for connectors on the Indigo I/O panel. However, if a board is designed to fit the Indy I/O panel space, it will also fit in an Indigo - provided it has the appropriate I/O panel. This single wide board in the drawing below shows the Indy style I/O panel, while the double wide board shows the Indigo style I/O panel. Dimensions for both of these panels are available in the GIO Bus Specification.

Board Outline

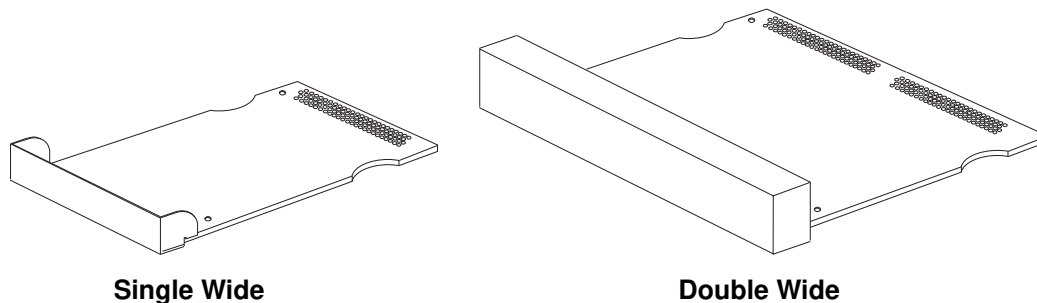

Figure 46 Single & Double GIO32/32-bis Boards

Power Budget

The following table shows the maximum current draw for voltages in a GIO slot.

Voltage	Current	Power
+ 5 V	2 A	10 W
+12 V	0.15 A	1.8 W
- 12 V	0.15 A	1.8 W
Total Power Budget (per slot)		13.6 W

Table 64 GIO32/32-bis Power Budget

Pinout

Consult the “GIO Bus Specification” for a complete pinout of the GIO32/32-bis bus.

GIO64 Bus

A GIO64 board is the same size as an EISA board. This is due to the fact that the two buses share four physical slots in the Indigo² (consult page 146 for a drawing and explanation).

The I/O panel space for a GIO64 board is identical to that for an EISA board.

Board Outline

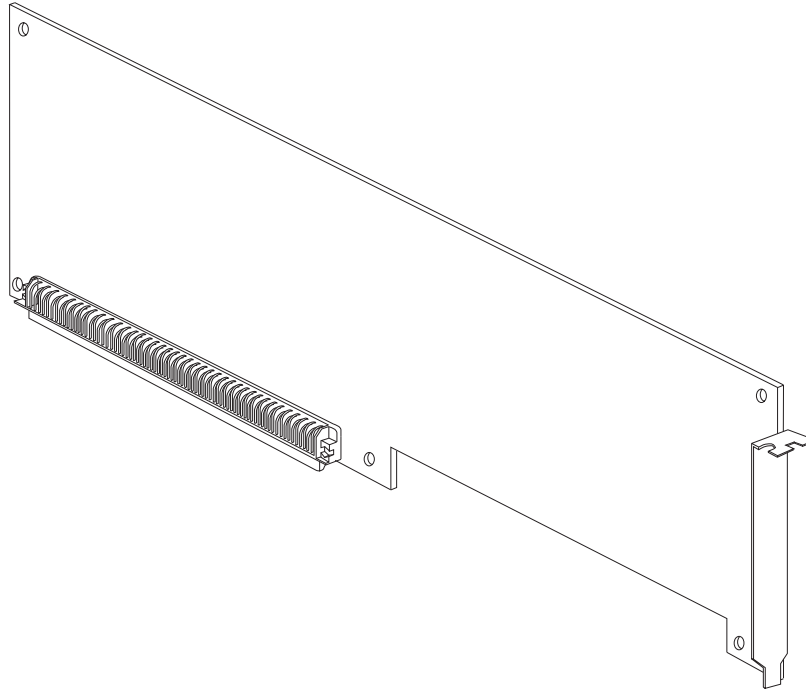

Figure 47 GIO64 Board

Power Budget

The following table shows the maximum current draw for voltages in a GIO64 slot.

Voltage	Current	Power
+ 5 V	4.5 A	22.5 W
+12 V	1 A	12 W
- 12 V	0.2 A	2.4 W
Total Power Budget (per slot)		36.9 W

Table 65 GIO64 Power Budget

Pinout

Consult the “GIO Bus Specification” for a complete pinout of the GIO64 bus.

EISA Bus

This is the same bus used by PC compatibles. EISA bus boards share four physical slots with GIO64 boards in the Indigo² (consult the section on backplanes for a drawing and explanation).

Since the EISA bus is a superset of the ISA bus, ISA boards will also fit into the Indigo².

An EISA or ISA board must have a software driver to integrate it with the IRIX operating system. This driver can be a user level driver or a kernel level driver. For more information about drivers in general, and EISA/ISA drivers specifically, consult the “IRIX Device Driver Programming Guide”.

Board Drawing

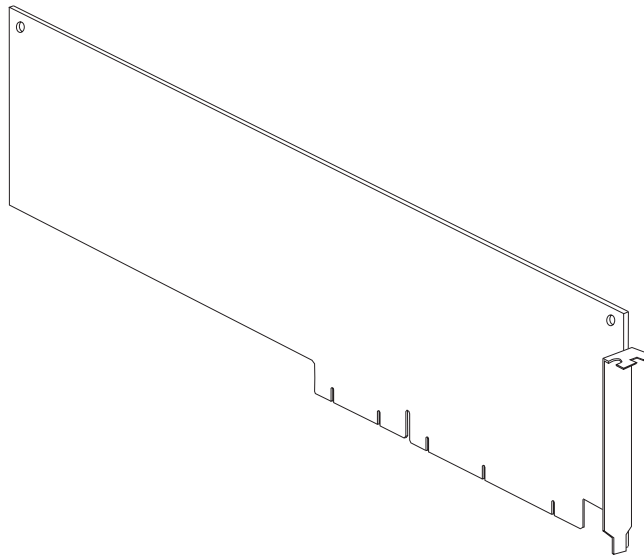

Figure 48 EISA Board

Power Budget

The following table shows the maximum current draw for voltages in a GIO64 slot.

Voltage	Current	Power
+ 5 V	4.5 A	22.5 W
- 5 V	2 A	10.0 W
+12 V	1.5 A	18.0W
- 12 V	0.3 A	3.6 W
Total Power Budget (per slot)		45.1 W

Table 66 EISA/ISA Power Budget

Pinout

Row F	Row B	Pin	Row A	Row E
GND	GND	1	IOCHK*	CMD*
+5 V	RESET	2	SD7	START*
+5 V	+5 V	3	SD6	EXRDY
Reserved	IRQ9	4	SD5	EX32*
Reserved	-5 V	5	SD4	GND
Key	DRQ2	6	SD3	Key
Reserved	-12 V	7	SD2	EX16*
Reserved	SRDY*	8	SD1	SLBURST*
+12 V	+12 V	9	SD0	MSBURST*
M-IO	GND	10	IOCHRDY	W-R
LOCK	SMEMW*	11	AENx	GND
Reserved	SMEMR*	12	SA19	Reserved
GND	IOW*	13	SA18	Reserved
Reserved	IOR*	14	SA17	Reserved
BE3*	DACK3*	15	SA16	GND
Key	DRQ3	16	SA15	Key
BE2*	DACK1*	17	SA14	BE1*
BE0*	DRQ1	18	SA13	LA31*
GND	REFRESH*	19	SA12	GND
+5 V	BCLK	20	SA11	LA30*
LA29*	IRQ7	21	SA10	LA28*
GND	IRQ6	22	SA9	LA27*
LA26*	IRQ5	23	SA8	LA25*
LA24*	IRQ4	24	SA7	GND
Key	IRQ3	25	SA6	Key
LA16	DACK2*	26	SA5	LA15
LA14	TC	27	SA4	LA13
+5 V	BALE	28	SA3	LA12
+5 V	+5 V	29	SA2	LA11
GND	OSC	30	SA1	GND
LA10	GND	31	SA0	LA9
Standard ISA Connections				
Extended ISA (EISA) Connections				

Table 67 EISA/ISA Connector Pinout (Large Connector)

Row H	Row D	Pin	Row C	Row G
LA8	MEMCS16*	1	SBHE*	LA7
LA6	IOCS16*	2	LA23	GND
LA5	IRQ10	3	LA22	LA4
+5 V	IRQ11	4	LA21	LA3
LA2	IRQ12	5	LA20	GND
Key	IRQ15	6	LA19	Key
DATA16	IRQ14	7	LA18	DATA17
DATA18	DACK0*	8	LA17	DATA19
GND	DRQ0	9	MEMR*	DATA20
DATA21	DACK5*	10	MEMW*	DATA22
DATA23	DRQ5	11	SD8	GND
DATA24	DACK6*	12	SD9	DATA25
GND	DRQ6	13	SD10	DATA26
DATA27	DACK7*	14	SD11	DATA28
Key	DRQ7	15	SD12	Key
DATA29	+5 V	16	SD13	GND
+5 V	MASTER16*	17	SD14	DATA30
+5 V	GND	18	SD15	DATA31
MAKx*		19		MREQx*
Standard ISA Connections				
Extended ISA (EISA) Connections				

Table 68 EISA/ISA Connector Pinout (Small Connector)