

Graphics Interfaces

There are a number of graphics related signals on IRIS systems. The one used most often is the monitor output. Others are Alpha channel output, genlock input and the stereo signal used by devices like the stereo glasses emitter.

There are two kinds of monitor connections used for IRIS systems - BNC's or a 13W3 connector.

Where BNC's are used, only Red, Green, and Blue (RGB) and Sync graphics signals destined for the monitor are provided. Where the 13W3 connector is used, the cable carries the RGB signals as well as some blanking signals and information on the type of monitor that is attached to the system. See the section on the 13W3 (page 95) interface for more information about the monitor identification signals.

Chassis	Graphics Subsystem	Monitor Output			Alpha		Genlock		Stereo Signal
		BNC's	13W3	S-VGA	Conn	In/Out	Conn	In/Out	Conn
Twin Tower	B, G	4							
	GT, GTX	4			BNC	In			
Diehard	GT, GTX	4			BNC	In			
	VGX, VGXT	4			BNC	In			PPP ²
Predator Rack		4							
Personal IRIS		3 ⁵	X ⁴	X ³			X	In	DB-15 ¹ Mini-DIN ⁶
Diehard2			X		X		X		PPP ² 13W
Terminator Rack	RE, RE ²		X		X		BNC	Both	PPP ² 13W3
Indigo	Starter		X	X					
	XS, XS24, XZ, Elan		X				BNC	In	Mini-DIN
Indigo ²	XZ, Extreme		X				Mini Coax	In	Mini-DIN
	XL		X						Mini-DIN
Indy			X						Mini-DIN

Table 32 Graphics Interfaces on IRIS Systems

1. Stereo sync signal was available as a pin on the DB-15 Genlock connector for Personal IRIS systems with GR1.2 or GR1.5 graphics boards.
2. Stereo sync signal available via the Powered Peripheral port.
3. Only available on those systems with a GR1.5 graphics board.
4. Only on those systems with an Elan graphics board. For this situation there are no BNC's.
5. If the system has an Elan graphics board there are no BNC's.
6. Personal IRIS systems with Elan graphics boards have the stereo signal on a mini-DIN.

BNC Monitor Output (R, G, B & Sync)

While most SGI systems have some sort of Sync output in addition to the RGB outputs, early IRIS systems had monitors that required a separate Sync signal rather than including the sync signal along with the Green signal as has now become the accepted norm.

Later monitors did not require the separate Sync signal, so only the R, G and B signals were used. In the table above, the number of BNC's found on the system is noted.

Some graphics subsystems could alter where or whether the Sync signal was sent out on one or more of the R, G or B signals. For more information on this capability consult the 'setmon' manual page.

Connector Drawing

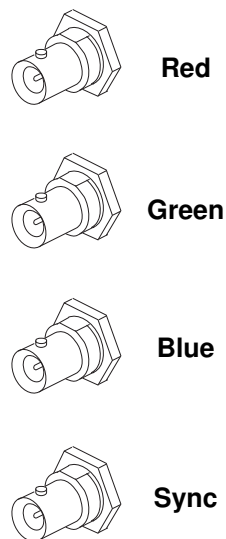

Figure 32 Typical RGB & Sync BNC Connectors

Output Levels

The output levels of the R, G and B signals are 714 millivolts peak to peak (from blank to white) not including sync. The sync signal is a 256 millivolt signal. When sync is present on Green the total peak to peak signal is 970 millivolts.

13W3 Monitor Output

The 13W3 style of monitor connection contains not only the R, G and B signals, but also horizontal and vertical blanking signals, monitor identification signals, and possibly a composite sync signal. While most of the signals on the 13W3 are identical on all systems, there are some signals that are found only on certain platforms. These differences are shown in Table 33, “13W3 Monitor Pinout”, on page 96.

The R, G and B signals are the same voltage levels as those specified in the section on BNC type connections.

Connector Drawing

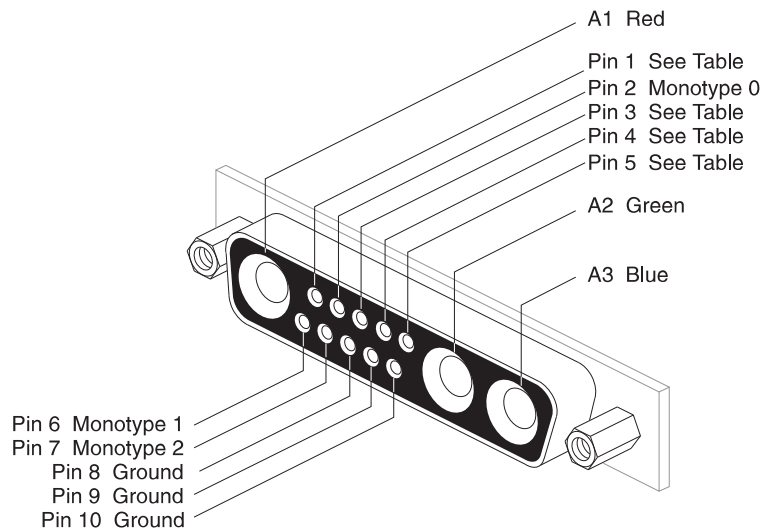

Figure 33 13W3 Monitor Output Connector

Monitor Identification Pins

The purpose of the monitor identification signals (a.k.a. Monitor ID or monotype signals) is to tell the graphics subsystem what type of a monitor is connected to the machine. This is done with 4 lines that are either grounded or left floating at the monitor. This happens during the booting of the system. The graphics subsystem can then adjust its timing to correspond to the type of monitor attached to the system.

Not all of the systems equipped with 13W3 connectors support all of the monitors that are possible. The table on page 97 shows how to equate the states of the Monitor ID pins with the type of the monitor.

Pinout

Pin	High End Systems			Mid and Low End Systems		
	Signal Name	Description	Input/Output	Signal Name	Description	Input/Output
A1	Red	Red Signal	Output	Same		
A2	Green	Green Signal	Output	Same		
A3	Blue	Blue Signal	Output	Same		
1		Cable Shield	-	Montype 3	Monitor type 3	Input
2	Montype 0	Monitor type 0	Input	Same		
3	N/C	No Connection		CSYNC	Composite Sync	Output
4	Stereo	Stereo Sync	Output	HDRIVE	Horizontal Drive	Output
5	Stereo Pwr	Power for Stereo emitter (+ 10V)	Output	VDRIVE	Vertical Drive	Output
6	Montype 1	Monitor type 1	Input	Same		
7	Montype 2	Monitor type 2	Input	Same		
8	GND	Ground	-	Same		
9	GND	Ground	-	Same		
10	GND	Ground	-	Same		

Table 33 13W3 Monitor Pinout

Description	ID Value ¹	Montype(n)					Scan Rates H/V	Size	Stereo?	Comments
		4 ²	3 ³	2	1	0				
		Pin 3	Pin 1	Pin 7	Pin 6	Pin 2				
Not Defined	0	N/A	Gnd	Gnd	Gnd	Gnd				
Multiscan -up to 1280x1024	1	N/A	Gnd	Gnd	Gnd	NC	30-82 kHz/ 76 Hz	19"	Yes	
Multiscan -up to 1280x1024	2	N/A	Gnd	Gnd	NC	Gnd	30-82 kHz/ 76 Hz	16"	Yes	
Not Defined	3	N/A	Gnd	Gnd	NC	NC				
Not Defined	4	N/A	Gnd	NC	Gnd	Gnd				
Not Defined	5	N/A	Gnd	NC	Gnd	NC				
Single Scan - 1024x768	6	N/A	Gnd	NC	NC	Gnd	48.48 kHz /60 Hz?	15"	No	For Indy
Not Defined	7	N/A	Gnd	NC	NC	NC				
1280x1024	8	N/A	NC	Gnd	Gnd	Gnd	60 Hz only	19"	Yes (both 492 & 512 Lines)	Hitachi Monitor
Multiscan - 1280x1024	9	N/A	NC	Gnd	Gnd	NC	30-82 kHz/ 76 Hz	19"	Yes	Can also be a single scan 72 Hz Sony
1280x1024	10	N/A	NC	Gnd	NC	Gnd	30-82 kHz/ 76 Hz	16"	Yes	
Multiscan - 1280x1024 & 1024x768	11	N/A	NC	Gnd	NC	NC		21"	Yes (both 492 & 512 Lines)	
Dual Scan - 1280x1024 & 1024x768	12	N/A	NC	NC	Gnd	Gnd	63.9 & 48.48 kHz /60 Hz	19"	Yes (both 492 & 512 Lines)	Shipped with original Indigo
Dual Scan - 1280x1024 & 1024x768	13	N/A	NC	NC	Gnd	NC	63.9 & 48.48 kHz /60 Hz	16"	Yes (both 492 & 512 Lines)	Shipped with original Indigo
Single Scan - 1024x768	14	N/A	NC	NC	NC	Gnd	48.48 kHz /60 Hz?	15"		For Indy
Single Scan- 1280x1024	15	N/A	NC	NC	NC	NC	63.9 kHz /60 Hz	19"	Yes	As shipped with Personal IRIS and 4D/ xxx series

Table 34: Monitor ID Definitions

Notes:

- 1 The Silicon Graphics system recognizes ID pins that are not connected as “high” and those grounded as “low”. Pins need not be pulled high, just left with no connection.
- 2 Montype4 pin not currently used. This pin (pin 3) is currently used for composite sync.
- 3 Monitor ID Values 0 - 7 used only by Indigo² (with XL graphics) and Indy. All other machines recognize Monitor ID Values of 8 - 15 only.

S-VGA Monitor Output

This is an output that conforms to the pinout used by PC compatibles for VGA (640 x 480) and Super VGA (800 x 600, 1024 x 768, 1280 x 1024) resolutions. On some systems this connector is referred to as the “composite” connector.

Connector Drawing

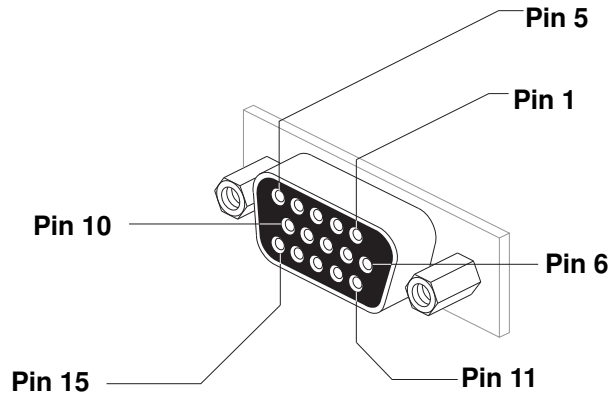

Figure 34 S-VGA Connector

Pinout

Pin	Signal Name	Description
1	RED.OUT	Red Output
2	GREEN.OUT	Green Output
3	BLUE.OUT	Blue Output
4	N/C	No Connection
5	DIG GND	Digital Ground
6	ARTN	Analog Return
7	ARTN	Analog Return
8	ARTN	Analog Return

Pin	Signal Name	Description
9	NO PIN	No Pin Installed ¹
10	DIG GND	Digital Ground
11	Montype 0	Monitor type 0
12	N/C	No Connection
13	HDRIVE.OUT	Horizontal Drive (TTL)
14	VDRIVE.OUT	Vertical Drive (TTL)
15	N/C	No Connection

Table 35 S-VGA Monitor Output Pinout

1. Some systems use a connector that does not have a pin hole for this pin.

Graphics Output Timing Information

IRIS systems support a number of different output formats. For external equipment to operate properly it is important to know the timing of various portions of the sync signals.

Note that these specifications apply to the “Graphics Output” - that output normally sent to the graphics monitor. This is not to be confused with “Video Output” - an output sent to a piece of video equipment (like a Video Recorder). There are some *graphics output* formats that comply with standard *video* standards, for example NTSC or PAL. In these situations the *graphics output* may be connected to a suitably equipped *video device*.

The tables on the following pages show the timing specifications for the formats supported by IRIS systems. Since there many number associated with the specifications for each format, there are two tables. Table 36 covers the general format information and the Horizontal specifications, while Table 37 covers the Vertical specifications. The formats listed in both Table 36 and Table 37 are numbered to make cross references between tables easier.

It is important to note that there are some differences between the timing specifications for “high end” systems (VGX, Reality Engine, etc) and those mid- and low-end systems (Indigo, Indigo² and Indy). These differences are shown in the tables with a format number with an “a” appended. For example, format “5” is the high-end video format while “5a” is the format for the mid- and low-end systems. In many cases the differences between the specifications are minor enough that a peripheral such as a monitor would work perfectly well with either. However, for some pieces of equipment these differences could be important. For each of these cases where the specs differ, the format number fields have been outlined to point out the two variations.

The most frequently encountered video output formats are lightly shaded. These formats, like 1280x1024 @ 60 Hz are those used by default by the system for the monitors supplied with the system.

Format	General Format				Pixel Clock		Horizontal										
	Resolution	Frame Rate (Hz)	Interlaced?	Fields			Active Line Length		Nominal Line Period (total width)		Line Frequency (KHz)	Sync Duration		Back Porch		Front Porch	
					Frequency (MHz)	Period (nsec)	Pixels	µsec	Pixels	µsec		Pixels	µsec	Pixels	µsec	Pixels	µsec
1	1200x900	72	No	1	105.581160	9.471387	1200	11.37	1565	14.82	67.464	90	0.85	240	2.27	35	0.33
2	1280x1024	60	No	1	107.352000	9.315150	1280	11.92	1680	15.65	63.900	120	1.12	240	2.24	40	0.37
2a														250	2.33	30	0.28
3	1280x1024	50	No	1	87.948000	11.370355	1280	14.55	1680	19.10	52.350	120	1.36	240	2.73	40	0.45
3a					89.460000	11.178180								14.31	18.78	50.00	1.34
4	1280x1024	72	No	1	130.075920	7.687818	1280	9.84	1690	12.99	76.968	140	1.08	240	1.85	30	0.23
4a		72.3			130.000	7.692307											
5	1280x1024	30	Yes	2	53.609400	18.653445	1280	23.88	1580	29.47	33.930	130	2.42	130	2.42	40	0.75
5a					53.676000	18.630300											
6	1280x960	76	No	1	126.790800	7.887008	1280	10.10	1660	13.09	76.380	125	0.99	230	1.81	25	0.20
7	1280x960	30	Yes	2	49.717800	20.113521	1280	25.75	1620	32.58	30.690	150	3.02	150	3.02	40	0.80
8	1920x1035	30	No	1	74.250000	13.468013	1920	25.86	2200	29.63	33.750	90	1.21	145	1.95	45	0.61
9	1600x1200	60	No	1	156.375000	6.394884	1600	10.23	2085	13.33	75.000	120	0.77	320	2.05	45	0.29
10	1600x1200	50	No	1	130.312500	7.673861	1600	12.28	2085	16.00	62.500	120	0.92	320	2.46	45	0.35
11	1025x768	60	No	1	64.389600	15.530458	1025	15.92	1320	20.50	48.780	80	1.24	140	2.17	75	1.16
11a	1024x768	59.63			64.000000	15.625000											
12	640x1024	60	No	1	53.676000	18.630300	640	11.92	840	15.65	63.900	60	1.12	125	2.33	15	0.28
13	640x480	60	No	1	25.200000	39.682540	640	25.40	800	31.75	31.500	95	3.77	50	1.98	15	0.60
14	640x486	30	Yes	2	12.285000	81.400081	640	52.10	780	63.49	15.750	60	4.88	55	4.48	25	2.04
15	640x496	60	No	1	25.200000	39.682540	640	25.40	800	31.75	31.500	95	3.77	50	1.98	15	0.60
16	640x512	60	No	1	26.640000	37.537538	640	24.02	800	30.03	33.300	55	2.06	85	3.19	20	0.75
17	640x640	60	No	1	33.565200	29.792762	640	19.07	830	24.73	40.440	80	2.38	100	2.98	10	0.30

Table 36: Graphics Output Timing Specifications - General & Horizontal Information

Format	General Format				Pixel Clock		Horizontal										
	Resolution	Frame Rate (Hz)	Interlaced?	Fields			Active Line Length		Nominal Line Period (total width)		Line Frequency (KHz)	Sync Duration		Back Porch		Front Porch	
					Frequency (MHz)	Period (nsec)	Pixels	µsec	Pixels	µsec		Pixels	µsec	Pixels	µsec	Pixels	µsec
18	645x486	30	Yes	2	12.285000	81.400081	645	52.50	780	63.49	15.750	60	4.88	55	4.48	20	1.63
18a	640x485				12.272727	81.481483	640	52.15		63.49			15.734	4.89	60		
19	745x224	60	No	1	23.940000	41.771094	745	31.12	950	39.68	25.200	90	3.76	105	4.39	10	0.42
20	770x576	25	Yes	2	14.843750	67.368421	770	51.87	950	64.00	15.625	70	4.72	380	25.60	25	1.68
20a	780x575				15.000000	66.666667	780	52.00		960			4.67	90	6.00	20	1.33
21	850x850	60	No	1	59.070000	16.929067	850	14.39	1100	18.62	53.700	80	1.35	160	2.71	10	0.17
22	960x620	60	No	1	54.432000	18.371546	960	17.64	1260	23.15	43.200	95	1.75	185	3.40	20	0.37
23	960x680	60	No	1	54.432000	18.371546	960	17.64	1260	23.15	43.200	95	1.75	185	3.40	20	0.37
24	960x680	50	No	1	45.738000	21.863658	960	20.99	1260	27.55	36.300	95	2.08	185	4.04	20	0.44
25	960x802	30	Yes	2	30.975000	32.284100	960	30.99	1180	38.10	26.250	85	2.74	105	3.39	30	0.97
26	1280x1024	60	No	1	107.352000	9.315150	1280	11.92	1680	15.65	63.900	120	1.12	240	2.24	40	0.37
26a		59.94			118.087000	8.468332		10.84	1850	15.67			63.83	1.02	250	2.12	200
27	1280x1024	60	No	1	105.840000	9.448224	1280	12.09	1680	15.87	63.900	120	1.13	240	2.27	40	0.38
28	1280x1024	50	No	1	105.000000	9.523810	1280	12.19	1680	16.00	62.500	120	1.14	240	2.29	40	0.38
28a		49.99			97.750000	10.23017		13.09		17.19			58.18	1.23	250	2.56	30
29	1025x768	96	No	2	103.425120	9.668831	1025	9.91	1335	12.91	77.472	105	1.02	180	1.74	25	0.24
30	640x512	120	No	2	54.048000	18.502072	640	11.84	800	14.80	67.560	55	1.02	85	1.57	20	0.37
31	815x611	120	No	2	83.070000	12.038040	815	9.81	1065	12.82	78.000	95	1.14	135	1.63	20	0.24
32	960x680	108	No	2	97.588800	10.247078	960	9.84	1255	12.86	77.760	95	0.97	180	1.84	20	0.20
33	1280x1024	25	Yes	2	105.000000	9.523810	1280	12.19	1680	16.00	62.500	120	1.14	240	2.29	40	0.38
34	1280x1024	30	Yes	2	105.840000	9.448224	1280	12.09	1680	15.87	63.000	120	1.13	240	2.27	40	0.38

Table 36: Graphics Output Timing Specifications - General & Horizontal Information

Format	General Format				Pixel Clock		Horizontal										
	Resolution	Frame Rate (Hz)	Interlaced?	Fields			Active Line Length		Nominal Line Period (total width)		Line Frequency (KHz)	Sync Duration		Back Porch		Front Porch	
					Frequency (MHz)	Period (nsec)	Pixels	μsec	Pixels	μsec		Pixels	μsec	Pixels	μsec	Pixels	μsec
35	1280x492	120	No	2	107.452800	9.306412	1280	11.91	1680	15.63	63.960	120	1.12	240	2.23	40	0.37
35a		119.89			107.352000	9.315150								11.92	15.65	63.90	250
36	1280x512	120	No	2	111.484800	8.969833	1280	11.48	1680	15.07	66.360	120	1.08	240	2.15	40	0.36
37	1920x1035	30	Yes	2	74.250000	13.468013	1920	25.86	2200	29.63	33.750	45	0.61	190	2.56	45	0.61
38	1920x1152	25	Yes	2	71.817500	13.924183	1920	26.73	2300	32.03	31.225	130	1.81	185	2.58	65	0.91
39	1920x1152	25	Yes	2	71.875000	13.913043	1920	26.71	2300	32.00	31.250	65	0.90	250	3.48	65	0.90
40	640x480	60	Yes	3	82.368000	12.140637	640	7.77	880	10.68	93.600	80	0.97	120	1.46	40	0.49
41	1280x960	30	Yes	6	164.736000	6.070319	1280	7.77	1760	10.68	93.600	160	0.97	240	1.46	80	0.49

Table 36: Graphics Output Timing Specifications - General & Horizontal Information

Format	Vertical														Notes			
	Field	Active	Lines Per Frame	Front Porch			Sync			Sync Pulse			Back Porch					
				Pixels	Lines	msec	Pixels	Lines	msec	Pixels	μsec	Count	Pixels	Lines		msec		
1	1	900	937	4695	3.0	0.04	6260	4.0	0.06	4695	44.47		46950	30.0	0.44			
2 & 2a	1	1024	1065	5040	3.0	0.05	5040	3.0	0.05	3360	31.30		58800	35.0	0.55			
3	1	1024	1047	5040	3.0	0.06	5040	3.0	0.06	3360	38.20		28560	17.0	0.32			
3a			1065										0.056	0.056	58800	35.0	0.657	
4	1	1024	1069	5070	3.0	0.04	5070	3.0	0.04	3380	25.98		65910	39.0	0.51			
4a			1064										0.039	0.039	57460	34.0	0.442	
5	1	1024	1131	6320	4.0	0.12	6320	4.0	0.12	4740	88.42		72680	46.0	1.36			
	2			5530	3.5	0.10	5530	3.5	0.10	5530	103.15							
5a	1			5530	3.5	0.103	6320	4.0	0.118						71890	45.5	1.339	
	2			6320	4.0	0.118									72680	46.0	1.354	
6	1	960	1005	4980	3.0	0.04	4980	3.0	0.04	3320	26.18		64740	39.0	0.51			
7	1 & 2	960	1023	4860	3.0	0.10	4860	3.0	0.10	710	14.28	6	42120	26.0	0.85			
8	1	1035	1125	11000	5.0	0.15	11000	5.0	0.15	8800	118.52		770000	35.0	1.04			
	2			12100	5.5	0.16	9900	4.5	0.13	9900	133.33							
9	1	1200	1250	10425	5.0	0.07	12510	6.0	0.08	10425	66.67		81315	39.0	0.52			
10	1	1200	1250	10425	5.0	0.08	12510	6.0	0.10	10425	80.00		81315	39.0	0.62			
11	1	768	813	3960	3.0	0.06	3960	3.0	0.06	2640	41.00		51480	39.0	0.80			
11a															0.80			
12	1	1024	1065	2520	3.0	0.05	2520	3.0	0.05	1680	31.30		29400	35.0	0.55	Pixel Replication		
13	1	480	525	8000	10.0	0.32	1600	2.0	0.06	800	31.75		26400	33.0	1.05			

Table 37: Graphics Output Timing Specifications - Vertical Information

Format	Vertical															Notes
	Field	Active	Lines Per Frame	Front Porch			Sync			Sync Pulse			Back Porch			
				Pixels	Lines	msec	Pixels	Lines	msec	Pixels	μsec	Count	Pixels	Lines	msec	
14	1 & 2	486	525	2340	3.0	0.19	2340	3.0	0.19	335	27.27	6	10920	14.0	0.89	
15	1	496	525	1600	2.0	0.06	1600	2.0	0.06	800	31.75		20000	25.0	0.79	
16	1	512	555	2400	3.0	0.09	2400	3.0	0.09	1600	60.06		29600	37.0	1.11	
17	1	640	674	2490	3.0	0.07	2490	3.0	0.07	1660	49.46		23240	28.0	0.69	
18	1 & 2	486	525	2340	3.0	0.19	2340	3.0	0.19	335	27.27	6	10920	14.0	0.89	NTSC
18a		485														
19	1	224	420	87400	92.0	3.65	5700	6.0	0.24	860	35.92	6	93100	98.0	3.89	
20	1 & 2	576	625	2375	2.5	0.16	2375	2.5	0.16	405	27.28	5	19000	20.0	1.28	PAL
20a		575														
21	1	850	895	3300	3.0	0.06	3300	3.0	0.06	2200	37.24		42900	39.0	0.73	
22	1	620	720	41580	33.0	0.76	3780	3.0	0.07	2520	46.30		80640	64.0	1.48	
23	1	680	720	3780	3.0	0.07	3780	3.0	0.07	2520	46.30		42840	34.0	0.79	
24	1	680	726	3780	3.0	0.08	3780	3.0	0.08	2520	55.10		50400	40.0	1.10	
25	1 & 2	802	875	3540	3.0	0.11	3540	3.0	0.11	530	17.11	6	36580	31.0	1.18	
26	1	1024	1065	5040	3.0	0.05	5040	3.0	0.05	3360	31.30		58800	35.0	0.55	
26a				5550		0.047	5550		0.047				64750		0.548	4:3 Pixel Ratio
27	1	1024	1050	5040	3.0	0.05	5040	3.0	0.05	3360	31.75		33600	20.0	0.32	
28	1	1024	1250	5040	3.0	0.05	5040	3.0	0.05	3360	32.00		369600	220.0	3.52	
28a			1164									171360	102			1.753

Table 37: Graphics Output Timing Specifications - Vertical Information

Format	Vertical															Notes
	Field	Active	Lines Per Frame	Front Porch			Sync			Sync Pulse			Back Porch			
				Pixels	Lines	msec	Pixels	Lines	msec	Pixels	μsec	Count	Pixels	Lines	msec	
29	1	1536	1614	4005	3.0	0.04	4005	3.0	0.04	2670	25.82		44055	33.0	0.43	New Style Stereo
	2									4005	38.72					
30	1	1024	1126	2400	3.0	0.04	2400	3.0	0.04	1600	29.60		36000	45.0	0.67	New Style Stereo
	2									2400	44.40					
31	1	1222	1300	3195	3.0	0.04	3195	3.0	0.04	2130	25.64		35145	33.0	0.42	New Style Stereo
	2									2400	44.40					
32	1	1360	1440	3765	3.0	0.04	3765	3.0	0.04	2510	25.72		42670	34.0	0.44	New Style Stereo
	2									3765	38.58					
33	1	2048	2500	5040	3.0	0.05	5040	3.0	0.05	3360	32.00		369600	220.0	3.52	Pixel Replication, Genlock, Framelock, Swap only on frame boundary
	2									5040	48.00					
34	1	2048	2100	5040	3.0	0.05	5040	3.0	0.05	3360	31.75		33600	20.0	0.32	Pixel Replication, Genlock, Framelock, Swap only on frame boundary
	2									5040	47.62					
35	1	1024	1066	5040	3.0	0.05	5040	3.0	0.05	3360	31.27		58800	35.0	0.55	Old-style Stereo
	2									5040	46.90					
35a						0.046			0.046						0.547	
36	1	1024	1106	5040	3.0	0.05	5040	3.0	0.05	3360	30.14		58800	35.0	0.53	Old-style Stereo
	2									5040	45.21					
37		1035	1125	Vertical Blanking Information Unavailable												
38	1	1152	1249	6900	3.0	0.10	4600	2.0	0.06	2300	32.03		98900	43.0	1.38	
	2			8050	3.5	0.11	3450	1.5	0.05	3450	48.04		101200	44.0	1.41	

Table 37: Graphics Output Timing Specifications - Vertical Information

Format	Vertical															Notes
	Field	Active	Lines Per Frame	Front Porch			Sync			Sync Pulse			Back Porch			
				Pixels	Lines	msec	Pixels	Lines	msec	Pixels	μsec	Count	Pixels	Lines	msec	
39	1 & 2	1152	1250	9515	4.1	0.13	1438400	625.4	20.01	575	8.00	2	102285	44.5	1.42	
40	1	480	1560	880	1.0	0.01	5280	6.0	0.06	800	9.71	6	29040	33.0	0.35	Field Sequential
	2						2640	3.0	0.03			3	31680	36.0	0.38	
	3						Vertical Blanking Information Unavailable									
41		960	3120	Vertical Blanking Information Unavailable												Field Sequential

Table 37: Graphics Output Timing Specifications - Vertical Information

Alpha Output

This output provides an analog signal most often used for combining the graphics output with video signals.

Alpha is a output that is an analog representation of the data in the alpha bits of the frame buffer. It has the same electrical characteristics as the RGB signals. Sync can be added to the Alpha output using the 'setmon' command.

Genlock

Genlock is used to keep the RGB output in synchronization with some external piece of equipment (slave mode). Most IRIS systems only have a Genlock input. Some of the systems have Genlock outputs as well, making it possible to sync other equipment with the output rate of the IRIS.

Genlock on the slave systems is enabled using 'setmon'. You have a choice between 300 mVolt or 4 Volt input sync levels. There is AGC on the genlock input, so it can lock between about 200 mVolt and 5 Volts. Genlock is required when driving stereo Head Mounted Displays from 2 Onyx's, or anytime you need to use the Swap Ready signal, for drawing synchronization

There are two different connectors used for Genlock signals - a BNC or mini-coax (75Ω SMB) connector. For both of these the signal itself is connected to the inner conductor while the outer conductor is used as a shield.

The genlock signal is an active-low, composite sync, 1 Volt Peak-to-peak signal. Although the input is clamped to 1 Volt, meaning a TTL input could be used, the 1 Volt signal is recommended.

Genlock Option

This connection is specific to the Personal IRIS series of systems. It contains an assortment of sync signal outputs, a sync signal input, the 5 LSB's of the Blue channel, and the stereo signal.

Connector Drawing

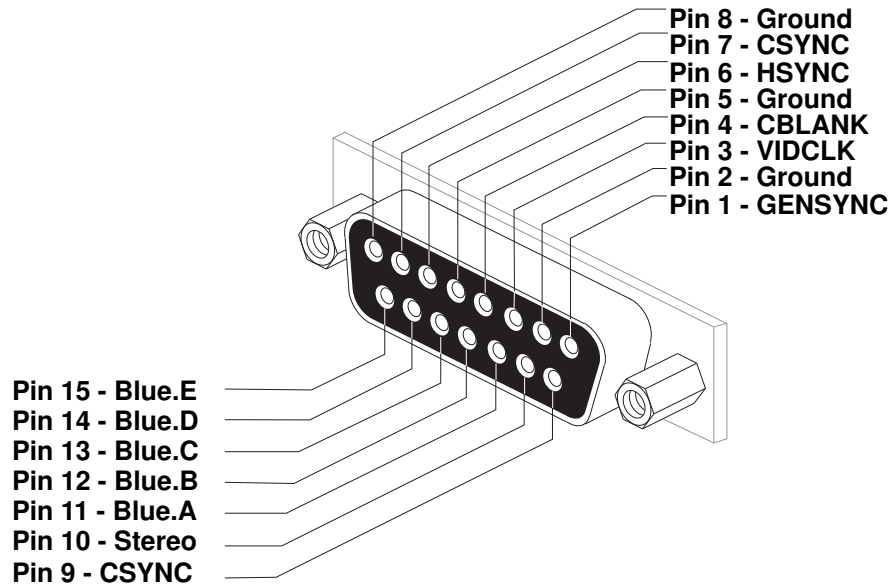

Figure 35 Genlock Option Connector

Pinout

Pin	Signal Name	Description	Input/Output
1	GENSYNC	Genlock Sync	Input
2	GND	Ground	-
3	VIDCLK	Video Clock	Output
4	CBLANK	Composite Blanking	Output
5	GND	Ground	-
6	HSYNC	Horiz. Sync	Output
7	CSYNC	Composite Sync	Output
8	GND	Ground	-

Pin	Signal Name	Description	Input/Output
9	EXTCSYNC	Ext. Composite Sync	Output
10	STEREO	Stereo Signal	Output
11	BLUE.A	5 Least Sig. Bits of Blue channel Used for generating a key	Output
12	BLUE.B		Output
13	BLUE.C		Output
14	BLUE.D		Output
15	BLUE.E		Output

Table 38 Genlock Option Connector Pinout

Stereo Sync Signal

The stereo sync signal indicates when the system is changing between buffers used to portray images for the right and left eye. The stereo signal is a TTL signal where the “high” state indicated the left eye view is being shown.

As the table on page 92 shows, there are four different connectors used for the stereo sync signal - a DB-15 Genlock connector, the Powered Peripheral Port, a 3 pin mini-DIN, connector, and as part of the 13W3 connector (only on some systems).

Since three of the four connectors are not used exclusively for the stereo sync signal, they are defined elsewhere. The pinout for the DB-15 Genlock Option connector is defined on page 108, the Powered Peripheral Port pinout is defined on page 52 and the pinout of the 13W3 is defined on page 95.

Connector Drawing (3 Pin Mini-DIN)

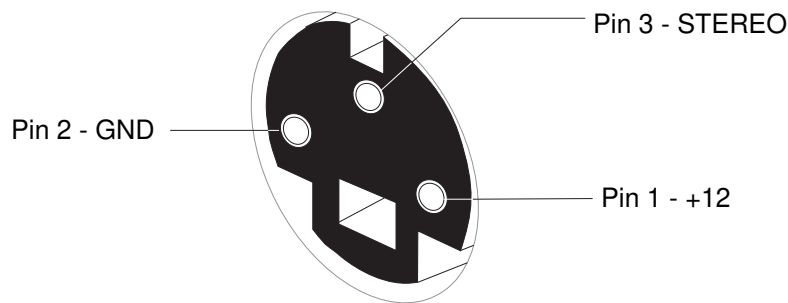

Pinout

Pin	Signal Name	Description	Input/Output
1	+12V	+12 Volts DC	Output
2	GND	Ground	-
3	STEREO	Stereo Sync	Output

Table 39 3 Pin Mini-DIN Stereo Sync Connector Pinout