

Monitors

There have been a number of monitor types used with SGI systems. The early systems used fixed frequency monitors. This carried through the Personal IRIS line of machines. With the Indigo, however, two different resolutions were supported, thus the need for a monitor that could handle either of these scan rates. This was known as a “dual scan” monitor.

As the graphics options grew, multi-scan monitors became cheaper, and ergonomic standards required higher scan rates, the monitors shipped with systems have phased over to multi-scan (or autoscan) monitors.

Monitor Connections

The type of connection has changed over time as well. Early monitors included BNC's for Red, Green, Blue and Sync. Eventually, monitors that would accept 'Sync on Green' were used obviating the need for the separate Sync connection.

With the Indigo, a new interconnection was used - the 13W3 connector. This allowed Red, Green and Blue along with some other signals to be made quickly with just one connection. The 13W3 connection is documented on page 95.

The other key feature of the 13W3 connection is that it allowed the system to determine (at boot time) the type of monitor connected to the system. This is accomplished with the Monitor Identification Pins (also documented in the section covering the 13W3 interface). This made it possible for the system to use the highest scan rate compatible with the monitor without having to go through some kind of configuration. This default setting could be overridden by using the 'setmon' command.

Another feature of some of the monitors is the support of 'stereo'. This doubles the scan rate (for example from 60 Hz to 120 Hz), halving the number of vertical lines shown per frame, and syncing a pair of external glasses so that each eye sees only every other frame. By drawing the appropriate images into the 'left' and 'right' frames of the graphics buffers, a 'stereo' image would appear. The signal used to synchronize the glasses is documented on page 109.

Monitor Drawings

Figures 24 through 31 on the following pages show drawings of the various types of monitors used on SGI systems. Note that not all of the monitors listed in Table 31 have corresponding drawings. Some of these monitors were used with MIPS based systems and so are listed but no drawings are included here. The monitors in the drawings represent the most frequently encountered models.

Other monitors differ only in a couple of letters of the Model Number. For example, CM2086A3SG, CM2086A3CD and CM2086A3PR. These are the Silicon Graphics (SG), Control Data (CD) and Prime Computers (PR) versions of the same monitor. The actual difference between these monitors is the color of, and the logo on, the monitor.

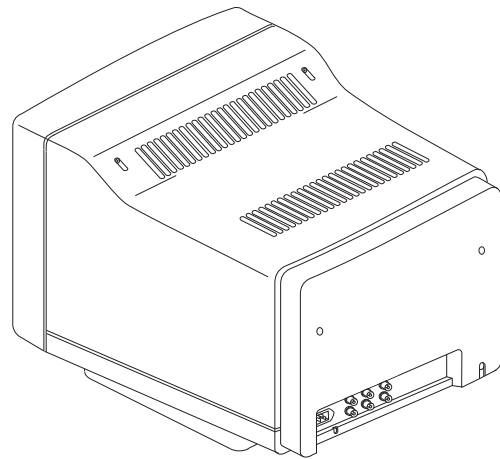
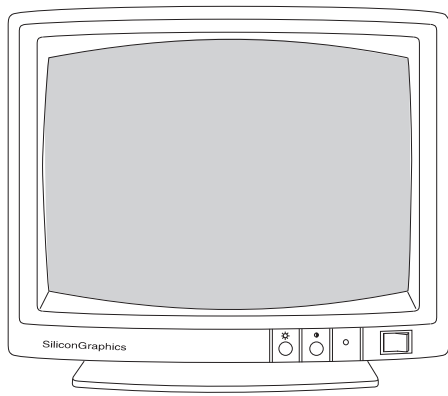
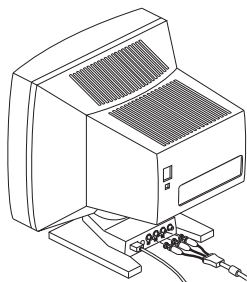
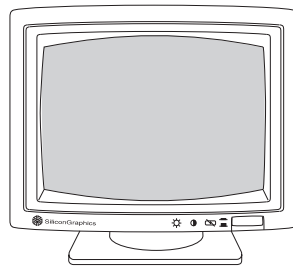
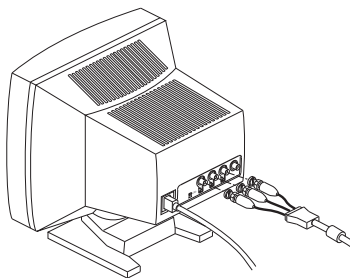

Figure 24 Hitachi CM2073 Monitor



Original Version



Revision C

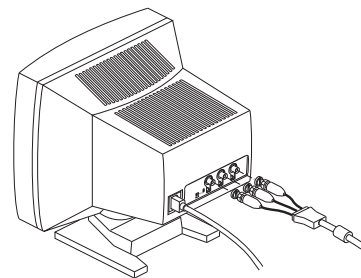

Revision D

Figure 25 Hitachi CM2086 Monitor

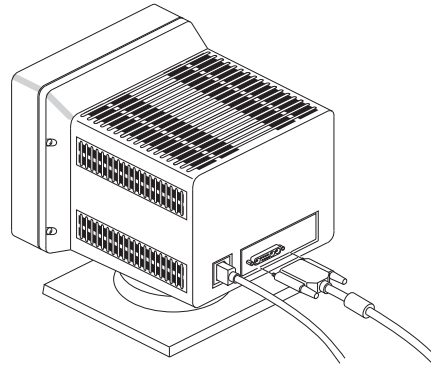
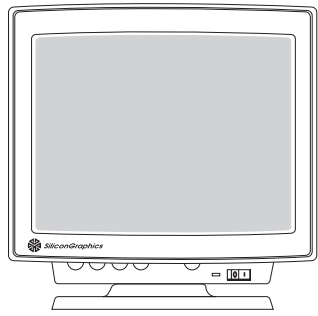

Figure 26 Sony GDM1630 Monitor

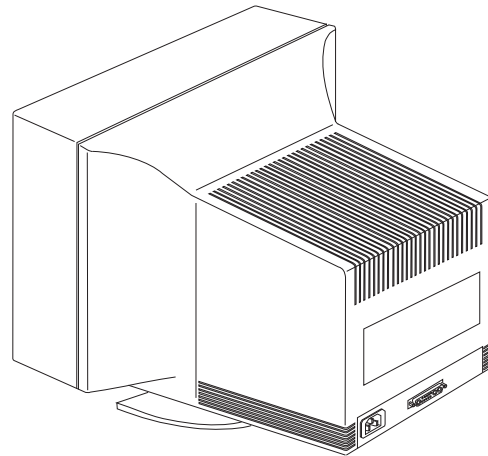
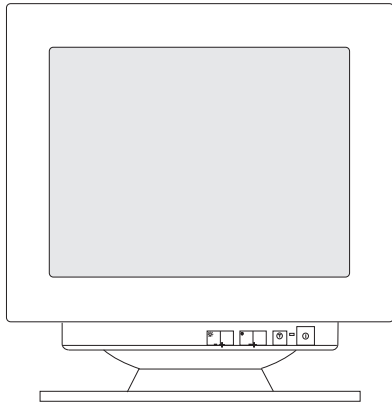

Figure 27 Mitsubishi HL6705 Monitor

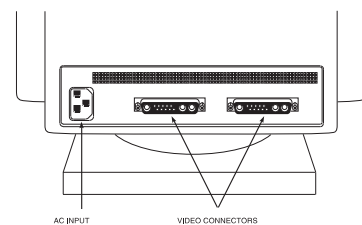
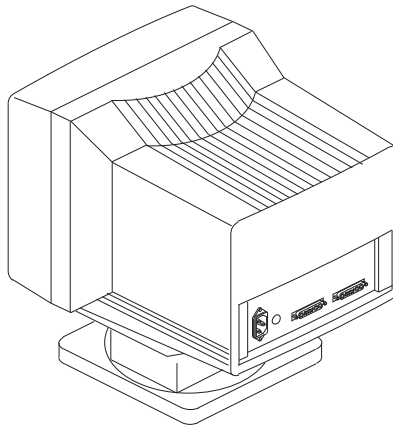
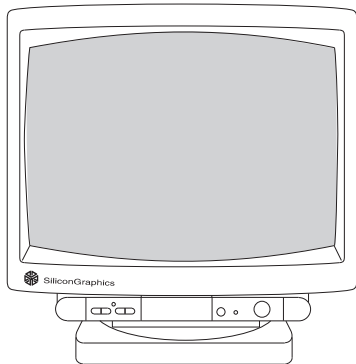

Figure 28 Mitsubishi HL7965 Monitor

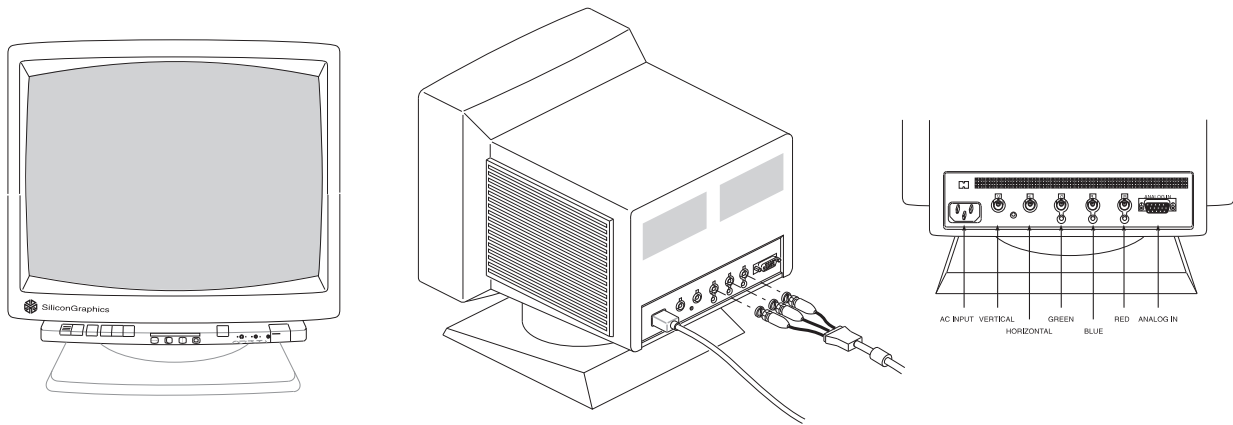

Figure 29 Hitachi CM2187 Monitor

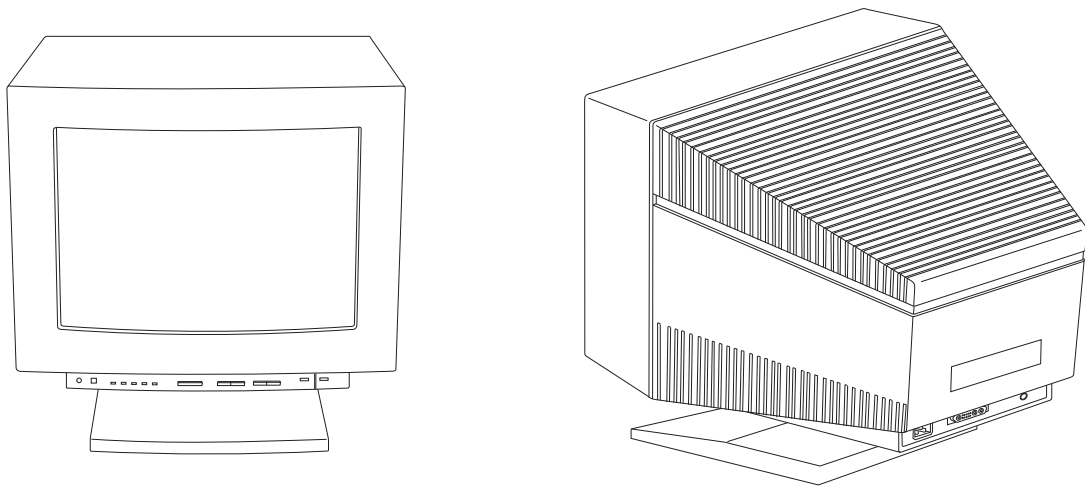

Figure 30 Sony GDM17E11 Monitor

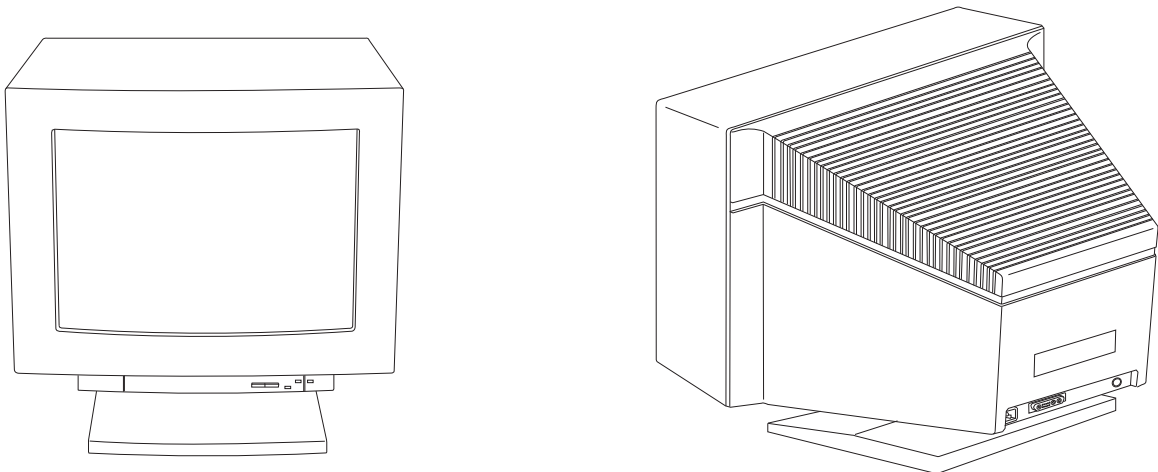

Figure 31 Sony GDM20D11 Monitor

Monitor Specifications

Table 31, on page 90 shows a listing of the different monitors that have been shipped with SGI systems. The table also documents other information about these monitors:

- manufacturer - who manufactured the monitor
- size - the diagonal size of the screen in inches
- model number - the manufacturer's model number (usually found on the back of the monitor)
- SGI part number - this SGI part number may or may not be on the back of the monitor. "SGI" indicates a monitor with the SGI logo on the front bezel.
- resolution - horizontal by vertical resolution of the monitor in pixels
- vertical and horizontal scan rate(s) - the vertical and horizontal frequencies that the monitor is capable of displaying
- stereo capable - whether the monitor supports stereo viewing in both 1280x512 and 1280x492 modes
- what kind of termination is done for video signals - the type of 75Ω termination used for the Red, Green and Blue signals.
 - "Input" indicates a permanently terminated input.
 - "Switch" indicates the termination may be switched on or off.
 - "Auto" indicates the output loop through has an automatic termination. If no connection is made to the output, the input is terminated. If a connection is made to the output, the termination is disconnected.
- loop through capable - whether the monitor supports an active or passive loop-through connection
- input - what type of input interface it has. All of the monitors in this table can utilize sync on the Green channel.
 - "RGBHV" indicates separate individual BNC connectors for Red, Green, Blue, Horizontal (if present), Vertical (if present). The horizontal connector (if present) will usually take a composite H/V sync instead of separate sync signals.
 - "RGB" indicates separate individual BNC connectors for Red, Green and Blue. No horizontal or vertical sync connections are present.
 - "13W3" indicates the large connector in a DB-25 shell with three coaxial connectors and ten individual pins.
 - DB-15 indicates the Video Graphics Adapter (VGA) connector.

This table is organized in roughly a chronological order showing the earliest monitors first.

Mfgr	Size	Model	SGI Part #	Resolution	Vertical Scan	Horizontal Scan	Stereo ?	Term	Loop	Input	Comments
Hitachi	19"	CM2073A	9330013	1280x1024	60 Hz	63.9 kHz	No	Switch	No	RGB	Original 4D Monitor
Hitachi	19"	CM2086A3SG rev C	9330017 SGI	1280x1024	60 Hz	63.9 kHz	No	Switch	No	RGB or H/V	
Hitachi	19"	CM2086A1SG rev C	9330018 SGI	1024x768	60 Hz	49.7 kHz	No	Switch	No	RGB	
Hitachi	19"	CM2086A3CD rev C	9330019	1280x1024	60 Hz	63.9 kHz	No	Switch	No	RGB	
Sony	19"	GDM-1950	9330020 SGI	1280x1024	60 Hz	63.9 kHz	No	Input	No	RGB	
Sony	19"	GDM-1950	9330038 SGI	1280x1024	60 Hz	63.9 kHz	No	Input	No	RGB	
Hitachi	19"	CM2086A3PR rev C	9330021	1280x1024	60 Hz	63.9 kHz	No	Switch	No	RGB	
Hitachi	19"	CM2086A3SG rev D	9330042 SGI	1280x1024	60 Hz	63.9 kHz	Yes	Switch	No	RGB	
Hitachi	19"	CM2086A3CD rev D	9330043	1280x1024	60 Hz	63.9 kHz	Yes	Switch	No	RGB	
Sony	16"	GDM-1630SG	9330040 SGI	1280x1024 1024x768	60 Hz 60 Hz	63.9 kHz 48.78 kHz	No	Switch Auto	Yes	RGBHV or H/V	
Sony	16"	GDM-1630SG	9330809 SGI	1280x1024 1024x768	60 Hz 59.64 Hz	63.9 kHz 48.48 kHz	No	Switch Auto	Yes	13W3	First shipped with Indigo
Sony	19"	GDM-1930SG	9330041 SGI	1280x1024 1024x768	60 Hz 59.64 Hz	63.9 kHz 48.48 kHz	No	Switch Auto	Yes	13W3	
Sony	19"	GDM-1930SG	9330810 SGI	1280x1024 1024x768	60 Hz 59.64 Hz	63.9 kHz 48.48 kHz	No	Switch Auto	Yes	13W3	First shipped with Indigo

Table 31 Silicon Graphics Display Monitors

Mfgr	Size	Model	SGI Part #	Resolution	Vertical Scan	Horizontal Scan	Stereo ?	Term	Loop	Input	Comments
Mitsubishi	19"	HL6905TK	9330028 SGI	1280x1024 1024x768	50-90 Hz autosync	30-64 kHz autosync	No	Switch	No	RGBHV or H/V	
Mitsubishi	19"	HL69SG	9330035 SGI	1280x1024 1024x768	50-125 Hz autosync	30-64 kHz autosync	Yes	Input	No	RGBHV or H/V	
Hitachi	21"	CM2187SG	9330044 SGI	1600x1200 to 640x480	50-120 Hz autosync	30-78 kHz	Yes	Switch	No	RGBHV or H/V DB-15	
Mitsubishi	19"	HL7965KW-CD	9330811	1280x1024 1024x768	50-130 Hz autosync	30-78 kHz autosync	Yes	Input	Yes	13W3	
Mitsubishi	19"	HL7965KW-SG	9330812 SGI	1280x1024 1024x768	50-130 Hz autosync	30-78 kHz autosync	Yes	Input	Yes	13W3	
Mitsubishi	16"	HL6705KW-CD	9330813	1280x1024 1024x768	50-130 Hz autosync	30-64 kHz autosync	Yes	Input	No	13W3	
Mitsubishi	16"	HL6705KW-SG	9330814 SGI	1280x1024 1024x768	50-130 Hz autosync	30-64 kHz autosync	Yes	Input	No	13W3	
Sony	16"	GDM-17E11			50-150 Hz	30-82 kHz	Yes	Input	No	13W3	
Sony	19"	GDM-20D11			50-150 Hz	48-82 kHz	Yes	Input	No	13W3	

Table 31 Silicon Graphics Display Monitors